

***Consultative
Committee for
Space Data Systems***

RECOMMENDATION FOR SPACE
DATA SYSTEM STANDARDS

**TELEMETRY
CHANNEL CODING**

CCSDS 101.0-B-3
BLUE BOOK

MAY 1992

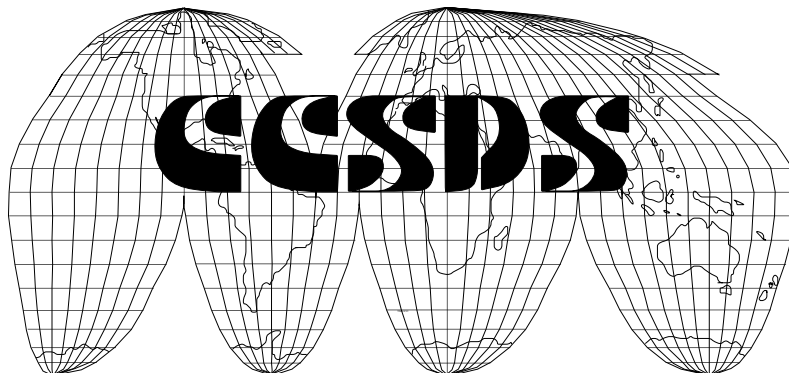

CCSDS HISTORICAL DOCUMENT

CCSDS RECOMMENDATION FOR TELEMETRY CHANNEL CODING

AUTHORITY

Issue:	Blue Book, Issue-3
Date:	May 1992
Location:	CCSDS Meeting, Oberpfaffenhofen, Germany

This Recommendation reflects the consensus technical agreement of the following member Agencies of the Consultative Committee for Space Data Systems (CCSDS):

- o British National Space Centre (BNSC)/United Kingdom
- o Canadian Space Agency (CSA)/Canada
- o Centre National d'Etudes Spatiales (CNES)/France
- o Deutsche Forschungsanstalt für Luft- und Raumfahrt (DLR)/Germany
- o European Space Agency (ESA)/Europe
- o Instituto de Pesquisas Espaciais (INPE)/Brazil.
- o National Aeronautics and Space Administration (NASA)/USA
- o National Space Development Agency of Japan (NASDA)/Japan

The following observer Agencies also concur with this Recommendation:

- o Department of Communications, Communications Research Centre (DOC-CRC)/Canada.
- o Institute of Space and Astronautical Science (ISAS)/Japan

This Recommendation is published and maintained by:

CCSDS Secretariat
Communications and Data Systems Division (Code-OS)
National Aeronautics and Space Administration
Washington, DC 20546, USA

CCSDS HISTORICAL DOCUMENT

CCSDS RECOMMENDATION FOR TELEMETRY CHANNEL CODING

STATEMENT OF INTENT

The Consultative Committee for Space Data Systems (CCSDS) is an organization officially established by the management of member space Agencies. The Committee meets periodically to address data systems problems that are common to all participants, and to formulate sound technical solutions to these problems. Inasmuch as participation in the CCSDS is completely voluntary, the results of Committee actions are termed RECOMMENDATIONS and are not considered binding on any Agency.

This RECOMMENDATION is issued by, and represents the consensus of, the CCSDS Plenary body. Agency endorsement of this RECOMMENDATION is entirely voluntary. Endorsement, however, indicates the following understandings:

- o Whenever an Agency establishes a CCSDS-related STANDARD, this STANDARD will be in accord with the relevant RECOMMENDATION. Establishing such a STANDARD does not preclude other provisions which an Agency may develop.
- o Whenever an Agency establishes a CCSDS-related STANDARD, the Agency will provide other CCSDS member Agencies with the following information:
 - The STANDARD itself.
 - The anticipated date of initial operational capability.
 - The anticipated duration of operational service.
- o Specific service arrangements shall be made via memoranda of agreement. Neither this RECOMMENDATION nor any ensuing STANDARD is a substitute for a memorandum of agreement.

No later than five years from its date of issuance, this Recommendation will be reviewed by the CCSDS to determine whether it should: (1) remain in effect without change; (2) be changed to reflect the impact of new technologies, new requirements, or new directions; or (3) be retired or cancelled.

CCSDS HISTORICAL DOCUMENT

CCSDS RECOMMENDATION FOR TELEMETRY CHANNEL CODING

FOREWORD

This document is a technical Recommendation for use in developing telemetry channel coding systems and has been prepared by the Consultative Committee for Space Data Systems (CCSDS). The telemetry channel coding concept described herein is the baseline concept for spacecraft-to-ground data communication within missions that are cross-supported between Agencies of the CCSDS.

This Recommendation establishes a common framework and provides a common basis for the coding schemes used on spacecraft telemetry streams. It allows implementing organizations within each Agency to proceed coherently with the development of compatible derived Standards for the flight and ground systems that are within their cognizance. Derived Agency Standards may implement only a subset of the optional features allowed by the Recommendation and may incorporate features not addressed by the Recommendation.

Through the process of normal evolution, it is expected that expansion, deletion or modification to this document may occur. This Recommendation is therefore subject to CCSDS document management and change control procedures which are defined in Reference [1].

CCSDS HISTORICAL DOCUMENT

CCSDS RECOMMENDATION FOR TELEMETRY CHANNEL CODING

DOCUMENT CONTROL

<u>Document/Title</u>	<u>Date</u>	<u>Status and Substantive Changes</u>
Recommendation for Space Data System Standards: Telemetry Channel Coding, Issue-1.	May 1984	Original Issue.
CCSDS 101.0-B-2, Recommendation for Space Data System Standards: Telemetry Channel Coding, Issue-2.	Jan. 1987	<ol style="list-style-type: none">1. Supersedes Issue-1.2. Removes ASM from R-S encoded data space.3. Specifies marker pattern for ASM.4. Transfers Annex A ("Rationale") to Green Book.
CCSDS 101.0-B-3, Recommendation for Space Data System Standards: Telemetry Channel Coding, Issue-3.	May 1992	<ol style="list-style-type: none">1. Supersedes Issue-2.2. Deletes Section 3 ("Convolutional Coding with Interleaving for Tracking and Data Relay Satellite Operations").3. Adds R-S interleave depths of I=2,3,4 to existing I=1 and 5.4. Allows R-S code to be operated in "Standalone Mode" (i.e., not concatenated with the convolutional code).5. Consolidates codeblock and transfer frame sync specifications (new Section 5).6. Specifies a standard Pseudo-Randomizer to improve bit synchronization (new Section 6).7. Corrects several editorial errors.

NOTE: Substantive technical changes from the previous issue are flagged with change bars in the margin

CCSDS HISTORICAL DOCUMENT

CCSDS RECOMMENDATION FOR TELEMETRY CHANNEL CODING

CONTENTS

<u>Sections</u>	<u>Page</u>
REFERENCES.....	vi
1 INTRODUCTION.....	1-1
1.1 PURPOSE.....	1-1
1.2 SCOPE.....	1-1
1.3 APPLICABILITY.....	1-2
1.4 BIT NUMBERING CONVENTION AND NOMENCLATURE.....	1-2
1.5 RATIONALE.....	1-3
2 CONVOLUTIONAL CODING.....	2-1
3 [Deleted.]	
4 REED-SOLOMON CODING.....	4-1
4.1 INTRODUCTION.....	4-1
4.2 SPECIFICATION.....	4-1
5 SYNCHRONIZATION.....	5-1
6 PSEUDO-RANDOMIZER.....	6-1
<u>Annexes</u>	
A [Deleted]	
B TRANSFORMATION BETWEEN BERLEKAMP AND CONVENTIONAL REPRESENTATIONS.....	B-1
C EXPANSION OF REED-SOLOMON COEFFICIENTS.....	C-1
D GLOSSARY OF TERMS.....	D-1
<u>Figures</u>	
2-1 Convolutional Encoder Block Diagram.....	2-2
4-1 Functional Representation of R-S Interleaving.....	4-2
4-2 Codeblock Partitioning.....	4-4
6-1 Pseudo-Randomizer Configuration.....	6-1
6-2 Pseudo-Randomizer Logic Diagram.....	6-3
B-1 Transformational Equivalence.....	B-2
<u>Table</u>	
B-1 Equivalence of Representations.....	B-5

CCSDS HISTORICAL DOCUMENT

CCSDS RECOMMENDATION FOR TELEMETRY CHANNEL CODING

REFERENCES

- [1] "Procedures Manual for the Consultative Committee for Space Data Systems", CCSDS A00.0-Y-5.0, Consultative Committee for Space Data Systems, May 1992 or later issue.
- [2] [Deleted.]
- [3] "Packet Telemetry", Recommendation CCSDS 102.0-B-2, Consultative Committee for Space Data Systems, January 1987 or later issue.
- [4] Perlman, M., and Lee, J., *Reed-Solomon Encoders - Conventional vs. Berlekamp's Architecture*, JPL Publication 82-71, NASA-Jet Propulsion Laboratory, Pasadena, California, December 1, 1982.
- [5] "Telemetry Concept and Rationale", CCSDS 100.0-G-1, Green Book, Consultative Committee for Space Data Systems, January 1987 or later issue.
- [6] "Minimum Modulated Symbol Transition Density on the Space-to-Earth Link", Recommendation CCSDS 401 (2.4.9) B-1, Consultative Committee for Space Data Systems, September 1989 or later issue.
- [7] "Advanced Orbiting Systems: Networks and Data Links," Recommendation CCSDS 701.0-B-1, Consultative Committee for Space Data Systems, October 1989 or later issue.

The latest issues of the CCSDS documents may be obtained from the CCSDS Secretariat at the address indicated on page i.

1 INTRODUCTION

1.1 PURPOSE

The purpose of this document is to establish a common Recommendation for space telemetry channel coding systems to provide cross-support among missions and facilities of member Agencies of the Consultative Committee for Space Data Systems (CCSDS.) In addition, it provides focusing for the development of multi-mission support capabilities within the respective Agencies to eliminate the need for arbitrary, unique capabilities for each mission.

Telemetry channel coding is a method of processing data being sent from a source to a destination so that distinct messages are created which are easily distinguishable from one another. This allows reconstruction of the data with low error probability, thus improving the performance of the channel.

1.2 SCOPE

Several space telemetry channel coding schemes are described in this document. The characteristics of the codes are specified only to the extent necessary to ensure interoperability and cross-support. The specification does not attempt to quantify the relative coding gain or the merits of each approach discussed, nor the design requirements for encoders or decoders. Some performance information is included in Reference [5].

This Recommendation does not require that coding be used on all cross-supported missions. However, for those planning to use coding, the recommended codes to be used are those described in this document.

The rate 1/2 convolutional code recommended for cross-support is described in Section 2, "Convolutional Coding". Depending on performance requirements, this code alone may be satisfactory.

For telecommunication channels which are bandwidth-constrained and cannot tolerate the increase in bandwidth required by the convolutional code in Section 2, the Reed-Solomon Code specified in Section 4 has the advantage of smaller bandwidth expansion and has the capability to indicate the presence of uncorrectable errors.

Where a greater coding gain is needed than can be provided by the convolutional code or Reed-Solomon code alone, a concatenation of the convolutional code as the inner code with the Reed-Solomon code as the outer code may be used for improved performance.

The recommended method for frame (or codeblock) synchronization is described in Section 5.

To improve bit transition density as an aid to bit synchronization, a recommended method of pseudo-randomizing data to be sent over the telemetry channel is described in Section 6.

Annex B provides a discussion of the transformation between the Berlekamp and conventional Reed-Solomon symbol representations; Annex C provides a table showing the expansion of the Reed-Solomon coefficients; and Annex D is a glossary of coding terminology used in this document.

1.3 APPLICABILITY

This Recommendation applies to telemetry channel coding applications of space missions anticipating cross-support among CCSDS member Agencies at the coding layer. In addition, it serves as a guideline for the development of compatible internal Agency Standards in this field, based on good engineering practice.

In addition to being applicable to conventional Packet Telemetry systems [3], the codes in this recommendation are applicable to the forward and return links of Advanced Orbiting Systems (AOS) [7]. For coding purposes, the terms "Transfer Frame" and "Reed-Solomon Codeblock" as used in this recommendation are understood to be equivalent to the AOS terms "Virtual Channel Data Unit" (VCDU), and "Coded Virtual Channel Data Unit" (CVCDU), respectively.

1.4 BIT NUMBERING CONVENTION AND NOMENCLATURE

In this document, the following convention is used to identify each bit in a forward-justified N-bit field. The first bit in the field to be transmitted (i.e., the most left justified when drawing a figure) is defined to be "Bit 0"; the following bit is defined to be "Bit 1" and so on up to "Bit N-1". When the field is used to express a binary value (such as a counter), the Most Significant Bit (MSB) shall be the first transmitted bit of the field, i.e., "Bit 0".

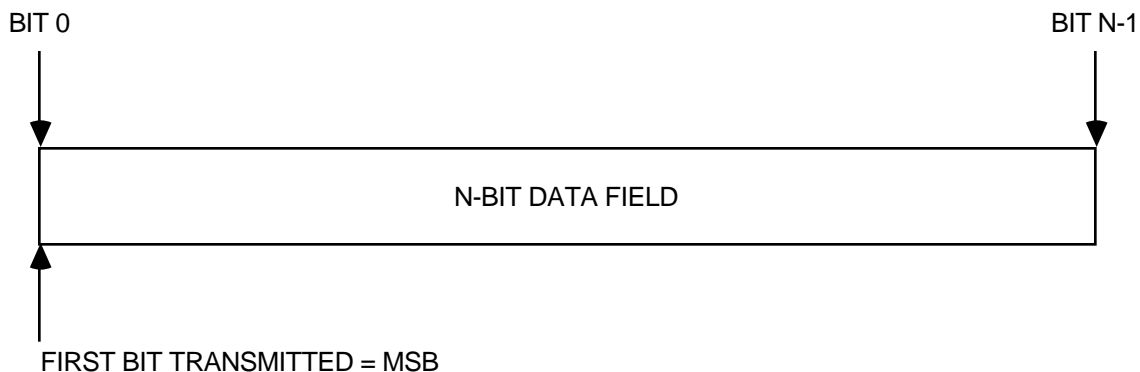

CCSDS HISTORICAL DOCUMENT

CCSDS RECOMMENDATION FOR TELEMETRY CHANNEL CODING

In accordance with modern data communications practice, spacecraft data fields are often grouped into 8-bit "words" which conform to the above convention. Throughout this Recommendation, the following nomenclature is used to describe this grouping:

8-BIT WORD = "OCTET"

1.5 RATIONALE

The CCSDS believes it is important to document the rationale underlying the standards chosen, so that future evaluations of proposed changes or improvements will not lose sight of previous decisions. The concept and rationale for Telemetry Channel Coding may be found in Reference [5].

2 CONVOLUTIONAL CODING

The basic code selected for cross-support is a rate 1/2, constraint-length 7, transparent convolutional code which is well suited for channels with predominantly Gaussian noise. The convolutional decoder is a maximum-likelihood (Viterbi) decoder. If the decoder's correction capability is exceeded, undetected burst errors may appear in the output. The code may be used alone, as described in this section, or in conjunction with enhancements described in the following sections.

This recommendation is a non-systematic code and a specific decoding procedure, with the following characteristics:¹

- | | |
|-------------------------|---|
| (1) Nomenclature: | Convolutional code with maximum-likelihood (Viterbi) decoding |
| (2) Code rate: | 1/2 bit per symbol |
| (3) Constraint length: | 7 bits |
| (4) Connection vectors: | G1 = 1111001; G2 = 1011011 |
| (5) Phase relationship: | G1 is associated with first Symbol |
| (6) Symbol inversion: | On output path of G2 |

An encoder block diagram is shown in Figure 2-1.

It is recommended that soft bit decisions with at least 3-bit quantization be used whenever constraints (such as location of decoder) permit.

¹ When suppressed-carrier modulation systems are used, NRZ-M or NRZ-L may be used as a modulating waveform. If the user contemplates conversion of his modulating waveform from NRZ-L to NRZ-M, such conversion should be performed on-board at the input to the convolutional encoder. Correspondingly, the conversion on the ground from NRZ-M to NRZ-L should be performed at the output of the convolutional decoder. This avoids unnecessary link performance loss.

CAUTION: When a fixed pattern (the fixed part of the convolutionally encoded Attached Sync Marker) in the symbol stream is used to provide node synchronization for the Viterbi decoder, care must be taken to account for any modification of the pattern due to the modulating waveform conversion.

CCSDS HISTORICAL DOCUMENT

CCSDS RECOMMENDATION FOR TELEMETRY CHANNEL CODING

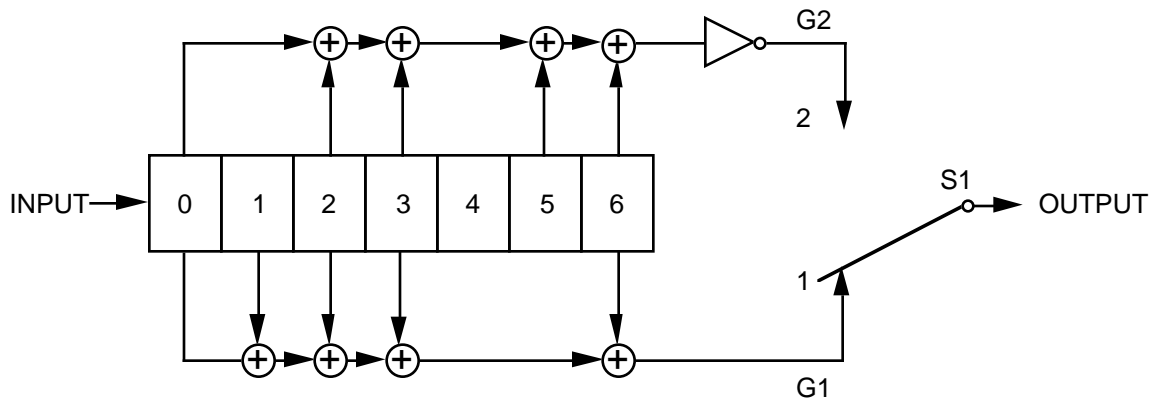

NOTES:

1.  = SINGLE BIT DELAY.

2. FOR EVERY INPUT BIT, TWO SYMBOLS ARE GENERATED BY COMPLETION OF A CYCLE FOR S1: POSITION 1, POSITION 2.

3. S1 IS IN THE POSITION SHOWN (1) FOR THE FIRST SYMBOL ASSOCIATED WITH AN INCOMING BIT.

4. \oplus = MODULO-2 ADDER.

5.  = INVERTER.

Figure 2-1: Convolutional Encoder Block Diagram

CCSDS HISTORICAL DOCUMENT

CCSDS RECOMMENDATION FOR TELEMETRY CHANNEL CODING

3 [Deleted.]

I

4 REED-SOLOMON CODING

4.1 INTRODUCTION

The Reed-Solomon code defined in this section is a powerful burst error correcting code. In addition, the code chosen has an extremely low undetected error rate. This means that the decoder can reliably indicate whether it can make the proper corrections or not. To achieve this reliability, proper codeblock synchronization is mandatory.

The Reed-Solomon code may be used alone, and as such it provides an excellent forward error correction capability in a burst-noise channel. However, should the Reed-Solomon code alone not provide sufficient coding gain, it may be concatenated with the convolutional code defined in Section 2. Used this way, the Reed-Solomon code is the *outer code*, while the convolutional code is the *inner code*.

4.2 SPECIFICATION

The parameters of the selected Reed-Solomon (R-S) code are as follows:

- (1) $J = 8$ bits per R-S symbol.
- (2) $E = 16$ R-S symbol error correction capability within a Reed-Solomon codeword.
- (3) General characteristics of Reed-Solomon codes:
 - (a) J , E , and I (the depth of interleaving) are independent parameters.
 - (b) $n = 2^J - 1 = 255$ symbols per R-S codeword.
 - (c) $2E$ is the number of R-S symbols among n symbols of an R-S codeword representing checks.
 - (d) $k = n - 2E$ is the number of R-S symbols among n R-S symbols of an R-S codeword representing information.
- (4) Field generator polynomial:

$$F(x) = x^8 + x^7 + x^2 + x + 1$$

over $GF(2)$.

CCSDS HISTORICAL DOCUMENT

CCSDS RECOMMENDATION FOR TELEMETRY CHANNEL CODING

- (5) Code generator polynomial:

$$g(x) = \prod_{j=112}^{143} (x - \alpha^{11j}) = \sum_{i=0}^{32} G_i x^i$$

over $GF(2^8)$, where $F(\alpha) = 0$.

It should be recognized that α^{11} is a primitive element in $GF(2^8)$ and that $F(x)$ and $g(x)$ characterize a (255,223) Reed-Solomon code.

- (6) The selected code is a systematic code. This results in a systematic codeblock.
- (7) Symbol Interleaving

The allowable values of interleaving depth are $I=1, 2, 3, 4,$ and 5 . $I=1$ is equivalent to the absence of interleaving. The interleaving depth shall normally be fixed on a physical channel for a mission. Symbol interleaving is accomplished in a manner functionally described with the aid of Figure 4-1. (It should be noted that this functional description does not necessarily correspond to the physical implementation of an encoder.)

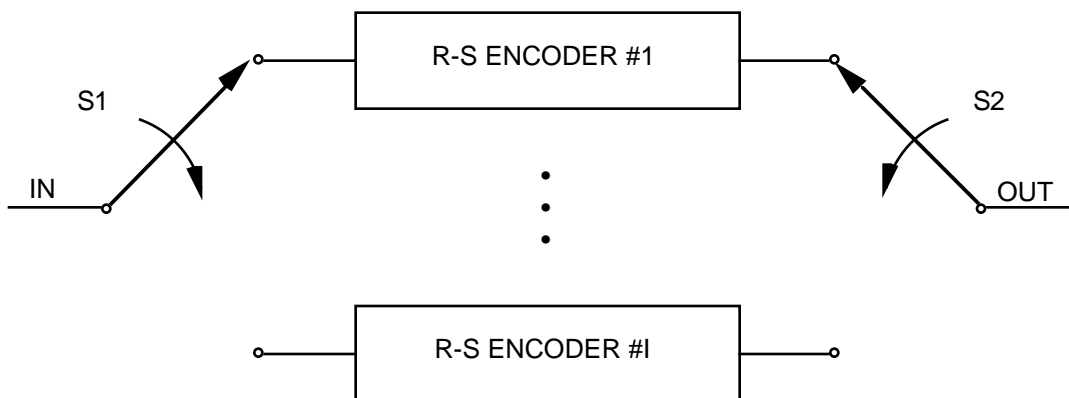

Figure 4-1: Functional Representation of R-S Interleaving

Data bits to be encoded into a single Reed-Solomon Codeblock enter at the port labeled "IN". Switches S1 and S2 are synchronized together and advance from encoder to encoder in the sequence 1,2, ... I, 1 ... , spending one R-S symbol time (8 bits) in each position.

One codeblock will be formed from 223I R-S symbols entering "IN". In this functional representation, a space of 32I R-S symbols in duration is required between each entering set of 223I R-S information symbols.

CCSDS HISTORICAL DOCUMENT

CCSDS RECOMMENDATION FOR TELEMETRY CHANNEL CODING

Due to the action of S1, each encoder accepts 223 of these symbols, each symbol spaced I symbols apart (in the original stream). These 223 symbols are passed directly to the output of each encoder. The synchronized action of S2 reassembles the symbols at the port labeled "OUT" in the same way as they entered at "IN".

Following this, each encoder outputs its 32 check symbols, one symbol at a time, as it is sampled in sequence by S2.

If, for $I=5$, the original symbol stream is

$$\begin{matrix} 1 & & 5 & 1 & & 5 & 1 & & 5 \\ d_1 & \dots & d_1 & d_2 & \dots & d_2 & \dots & d_{223} & \dots & d_{223} \end{matrix} \quad [32 \times 5 \text{ spaces}]$$

then the output is the same sequence with the [32 x 5 spaces] filled by the [32 x 5] check symbols as shown below:

$$\begin{matrix} 1 & & 5 & & 1 & & 5 \\ p_1 & \dots & p_1 & \dots & p_{32} & \dots & p_{32} \end{matrix}$$

where

$$\begin{matrix} i & i & & i & & i \\ d_1 & d_2 & \dots & d_{223} & p_1 & \dots & p_{32} \end{matrix}$$

is the R-S codeword produced by the i th encoder. If q virtual fill symbols are used in each codeword, then replace 223 by $(223 - q)$ in the above discussion.

With this method of interleaving, the original kI consecutive information symbols that entered the encoder appear unchanged at the output of the encoder with $2EI$ R-S check symbols appended.

(8) Maximum Codeblock Length

The maximum codeblock length, in R-S symbols, is given by:

$$L_{\max} = nI = (2^J - 1)I = 255I$$

CCSDS HISTORICAL DOCUMENT

CCSDS RECOMMENDATION FOR TELEMETRY CHANNEL CODING

(9) Shortened Codeblock Length¹

A shortened codeblock length may be used to accommodate frame lengths smaller than the maximum. However, since the Reed-Solomon code is a block code, the decoder must always operate on a full block basis. To achieve a full codeblock, "virtual fill" must be added to make up the difference between the shortened block and the maximum codeblock length. The characteristics and limitations of virtual fill are covered in paragraph (10). Since the virtual fill is not transmitted, both encoder and decoder must be set to insert it with the proper length for the encoding and decoding processes to be carried out properly.

When an encoder (initially cleared at the start of a block) receives $kI-Q$ symbols representing information (where Q , representing fill, is a multiple of I , and is less than kI), $2EI$ check symbols are computed over kI symbols, of which the leading Q symbols are treated as all-zero symbols. A $(nI-Q, kI-Q)$ shortened codeblock results where the leading Q symbols (all zeros) are neither entered into the encoder nor transmitted.

(10) Partitioning and Virtual Fill

The codeblock is partitioned as shown in Figure 4-2.

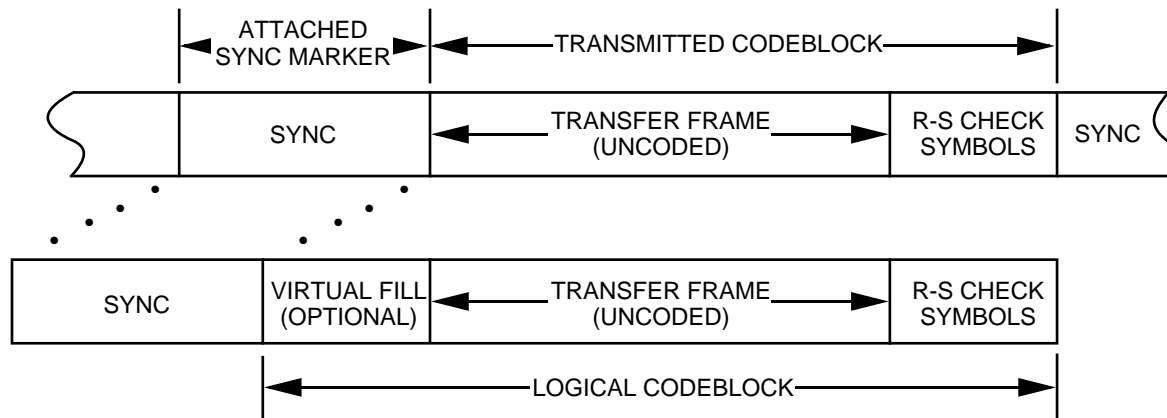

Figure 4-2: Codeblock Partitioning

¹ It should be noted that shortening the transmitted codeblock length in this way changes the overall performance to a degree dependent on the amount of virtual fill used. Since it incorporates no virtual fill, the maximum Packet Telemetry transfer frame length recommended in Reference [3] allows full performance. In addition, as virtual fill in a codeblock is increased (at a specific bit rate), the number of codeblocks per unit time that the decoder must handle increases. Therefore, care should be taken so that the maximum operating speed of the decoder (codeblocks per unit time) is not exceeded.

CCSDS HISTORICAL DOCUMENT

CCSDS RECOMMENDATION FOR TELEMETRY CHANNEL CODING

The **Reed-Solomon Check Symbols** consist of the trailing 2EI symbols (2EIJ bits) of the codeblock. (As an example, for I=5 this is always 1280 bits.)

The **Telemetry Transfer Frame** is defined by the CCSDS Recommendation for Packet Telemetry (Reference [3]). Whether used with R-S coding or not, it has a maximum length of 8920 bits, not including the 32-bit Attached Sync Marker.

The **Attached Sync Marker** is a 32-bit pattern specified in Section 5 as an aid to synchronization, and precedes the Telemetry Transfer Frame (if R-S coding is NOT used) or the Transmitted Codeblock (if R-S coding IS used). Frame synchronizers should, therefore, be set to expect a marker at every Telemetry Transfer Frame + 32 bits (if not R-S coded,) or at every Transmitted Codeblock + 32 bits.

The **Transmitted Codeblock** consists of the Telemetry Transfer Frame (without the 32-bit sync marker) and R-S check symbols. It is the received data entity physically fed into the R-S decoder. (As an example, using I=5 and no virtual fill, the length of the transmitted codeblock will be 10,200 bits; if virtual fill is used, it will be incrementally shorter, depending on the amount used.)

The **Logical Codeblock** is the logical data entity operated upon by the R-S decoder. It can have a different length than the transmitted codeblock because it accounts for the amount of virtual fill that was introduced. (As an example, for I=5 the logical codeblock always appears to have exactly 10,200 bits in length.)

Virtual fill is used to logically complete the codeblock and is not transmitted. If used, virtual fill shall:

- (a) Consist of all zeros.
- (b) Not be transmitted.
- (c) Not change in length during a tracking pass.
- (d) Be inserted only at the beginning of the codeblock (i.e., after the attached sync marker but before the beginning of the transmitted codeblock).
- (e) Be inserted only in integer multiples of 8I bits.

(11) Dual basis symbol representation and ordering for transmission

Each 8-bit Reed-Solomon symbol is an element of the finite field GF(256). Since GF(256) is a vector space of dimension 8 over the binary field GF(2), the actual 8-bit representation of a symbol is a function of the particular basis that is chosen.

CCSDS HISTORICAL DOCUMENT

CCSDS RECOMMENDATION FOR TELEMETRY CHANNEL CODING

One basis for GF(256) over GF(2) is the set $\{1, \alpha^1, \alpha^2, \dots, \alpha^7\}$. This means that any element of GF(256) has a representation of the form

$$u_7\alpha^7 + u_6\alpha^6 + \dots + u_1\alpha^1 + u_0\alpha^0$$

where each u_i is either a zero or a one.

Another basis over GF(2) is the set $(1, \beta^1, \beta^2, \dots, \beta^7)$ where $\beta = \alpha^{117}$. To this basis there exists a so-called "dual basis" $(\ell_0, \ell_1, \dots, \ell_7)$. It has the property that

$$\text{Tr}(\ell_i\beta^j) = \begin{cases} 1, & \text{if } i = j \\ 0, & \text{otherwise} \end{cases}$$

for each $j = 0, 1, \dots, 7$. The function $\text{Tr}(z)$, called the "trace", is defined by

$$\text{Tr}(z) = \sum_{k=0}^7 z^{2^k}$$

for each element z of GF(256). Each Reed-Solomon symbol can also be represented as

$$z_0\ell_0 + z_1\ell_1 + \dots + z_7\ell_7$$

where each z_i is either a zero or a one.

The representation used in this recommendation is the dual basis eight-bit string z_0, z_1, \dots, z_7 , transmitted in that order (i.e., with z_0 first). The relationship between the two representations is given by the two equations

$$[z_0, \dots, z_7] = [u_7, \dots, u_0] \begin{bmatrix} 1 & 0 & 0 & 0 & 1 & 1 & 0 & 1 \\ 1 & 1 & 1 & 0 & 1 & 1 & 1 & 1 \\ 1 & 1 & 1 & 0 & 1 & 1 & 0 & 0 \\ 1 & 0 & 0 & 0 & 0 & 1 & 1 & 0 \\ 1 & 1 & 1 & 1 & 1 & 0 & 1 & 0 \\ 1 & 0 & 0 & 1 & 1 & 0 & 0 & 1 \\ 1 & 0 & 1 & 0 & 1 & 1 & 1 & 1 \\ 0 & 1 & 1 & 1 & 1 & 0 & 1 & 1 \end{bmatrix}$$

and

$$[u_7, \dots, u_0] = [z_0, \dots, z_7] \begin{bmatrix} 1 & 1 & 0 & 0 & 0 & 1 & 0 & 1 \\ 0 & 1 & 0 & 0 & 0 & 0 & 1 & 0 \\ 0 & 0 & 1 & 0 & 1 & 1 & 1 & 0 \\ 1 & 1 & 1 & 1 & 1 & 1 & 0 & 1 \\ 1 & 1 & 1 & 1 & 0 & 0 & 0 & 0 \\ 0 & 1 & 1 & 1 & 1 & 0 & 0 & 1 \\ 1 & 0 & 1 & 0 & 1 & 1 & 0 & 0 \\ 1 & 1 & 0 & 0 & 1 & 1 & 0 & 0 \end{bmatrix}$$

CCSDS HISTORICAL DOCUMENT

CCSDS RECOMMENDATION FOR TELEMETRY CHANNEL CODING

Further information relating the dual basis (Berlekamp) and conventional representations is given in Annex B. Also included is a recommended scheme for permitting the symbols generated in a conventional encoder to be transformed to meet the symbol representation required by this document.

(12) Synchronization

Codeblock synchronization of the Reed-Solomon decoder is achieved by synchronization of the Attached Sync Marker associated with each codeblock. (See Section 5.)

(13) Ambiguity Resolution

The ambiguity between true and complemented data must be resolved so that only true data is provided to the Reed-Solomon decoder. Data in NRZ-L form is normally resolved using the 32-bit Attached Sync Marker, while NRZ-M data is self-resolving.

5 SYNCHRONIZATION

5.1 INTRODUCTION

Frame or Codeblock synchronization is necessary for proper decoding of the Reed-Solomon Codeblock and subsequent processing of the Transfer Frames. Furthermore, it is necessary for synchronization of the pseudo-random generator, if used (See Section 6). It is also useful in assisting the node synchronization process of the Viterbi decoder for the convolutional code.

Synchronization of the Codeblock (or Transfer Frame, if the telemetry channel is not Reed-Solomon coded) is achieved by using a stream of fixed-length Codeblocks (or Transfer Frames) with an Attached Sync Marker (ASM) between them. Synchronization is acquired on the receiving end by recognizing the specific bit pattern of the ASM in the telemetry channel data stream; synchronization is then customarily confirmed by making further checks.

5.2 ASM BIT PATTERN

The ASM for the telemetry channel data stream shall consist of a 32-bit (4-octet) marker with a pattern as follows:

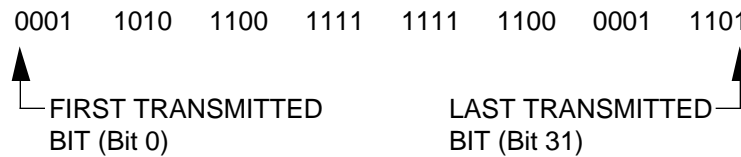

The pattern is represented in hexadecimal notation as:

1ACFFC1D

5.3 LOCATION OF ASM

The ASM is attached to (i.e., shall immediately precede) the Reed-Solomon Codeblock (or the Transfer Frame if the telemetry channel is not Reed-Solomon coded).

The ASM for one Codeblock (or Transfer Frame) shall immediately follow the end of the preceding Codeblock (or Transfer Frame); i.e., there shall be no intervening bits (data or fill) preceding the ASM.

5.4 RELATIONSHIP OF ASM TO R-S CODEBLOCK

Since the ASM is NOT a part of the encoded data space of the Reed-Solomon Codeblock, it is not presented to the input of the Reed-Solomon encoder or decoder. This prevents the encoder from routinely regenerating a second, identical marker in the check symbol field under certain repeating data-dependent conditions (e.g., a test pattern of 0101010101 ... among others) which could cause synchronization difficulties at the receiving end.

The relationship among the ASM, Reed-Solomon Codeblock, Transfer Frame and virtual fill is illustrated in Figure 4-2.

5.5 ASM FOR EMBEDDED DATA STREAM

A different ASM pattern may be required where another data stream (e.g., a stream of transfer frames played back from a tape recorder in the forward direction) is inserted into the data field of the Transfer Frame of the main stream appearing on the telemetry channel. The ASM for the embedded data stream, to differentiate it from the main stream marker, shall consist of a 32-bit (4-Octet) marker with a pattern as follows:

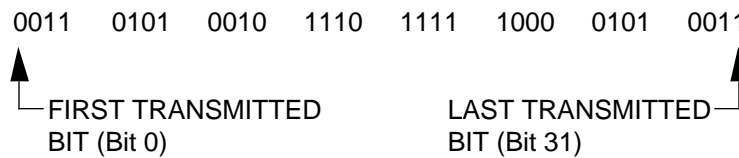

The pattern is represented in hexadecimal notation as:

352EF853

6 PSEUDO-RANDOMIZER

6.1 INTRODUCTION

In order to maintain bit (or symbol) synchronization with the received telemetry signal, every ground data capture system requires that the incoming signal have a minimum bit transition density (See Ref. [6]).

If a sufficient bit transition density is not ensured for the channel by other methods (e.g., by use of certain modulation techniques or one of the recommended convolutional codes) then the Pseudo-Randomizer defined in this section is required. Its use is optional otherwise.

The presence or absence of Pseudo-Randomization is fixed for a physical channel and is *managed* (i.e., its presence or absence is not signalled in the telemetry but must be known a-priori by the ground system).

6.2 PSEUDO-RANDOMIZER DESCRIPTION

The method for ensuring sufficient transitions is to exclusive-OR each bit of the Codeblock or Transfer Frame with a standard pseudo-random sequence. On the receiving end, the same sequence is exclusive-ORed with the received Codeblock or Transfer Frame to remove the randomized pattern and restore the original data.

If the Pseudo-Randomizer is used, on the sending end it is applied to the Codeblock or Transfer Frame but before convolutional encoding. On the receiving end, it is applied to de-randomize the data after convolutional decoding and codeblock synchronization but before Reed-Solomon decoding, if used.

The configuration at the sending end is shown in Figure 6-1.

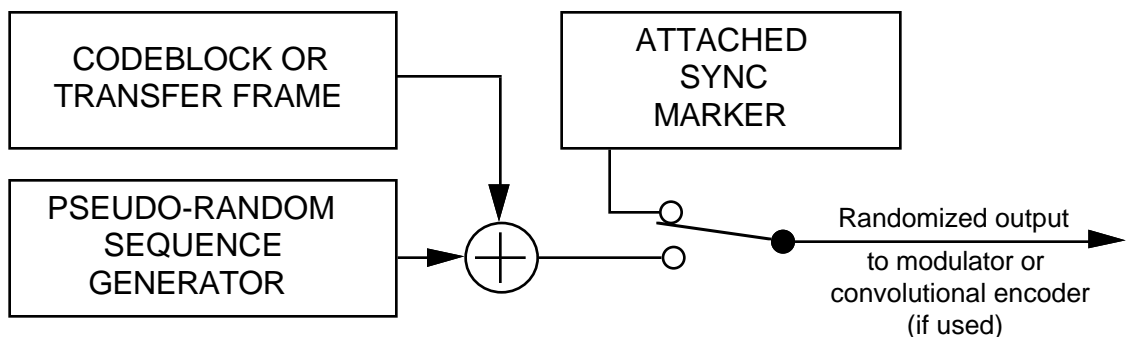

Figure 6-1: Pseudo-Randomizer Configuration

6.3 SYNCHRONIZATION AND APPLICATION OF PSEUDO-RANDOMIZER

The Attached Sync Marker (ASM) is already optimally configured for synchronization purposes and it is therefore used for synchronizing the Pseudo-Randomizer.

The pseudo-random sequence is applied starting with the first bit of the Codeblock or Transfer Frame. On the sending end, the Codeblock or Transfer Frame is randomized by exclusive-ORing the first bit of the Codeblock or Transfer Frame with the first bit of the pseudo-random sequence, followed by the second bit of the Codeblock or Transfer Frame with the second bit of the pseudo-random sequence, and so on.

On the receiving end, the original Codeblock or Transfer Frame is reconstructed using the same pseudo-random sequence. After locating the ASM in the received data stream, the pseudo-random sequence is exclusive-ORed with the data bits immediately following the ASM. The pseudo-random sequence is applied by exclusive-ORing the first bit following the ASM with the first bit of the pseudo-random sequence, followed by the second bit of the data stream with the second bit of the pseudo-random sequence, and so on.

The pseudo-random sequence shall NOT be exclusive-ORed with the ASM.

6.4 SEQUENCE SPECIFICATION

The pseudo-random sequence shall be generated using the following polynomial:

$$h(x) = x^8 + x^7 + x^5 + x^3 + 1$$

This sequence begins at the first bit of the Codeblock or Transfer Frame and repeats after 255 bits, continuing repeatedly until the end of the Codeblock or Transfer Frame. The sequence generator is re-initialized to an all-ones state during each ASM period.

The first 40 bits of the pseudo-random sequence from the generator are shown below; the left-most bit is the first bit of the sequence to be exclusive-ORed with the first bit of the Codeblock or Transfer Frame; the second bit of the sequence is exclusive-ORed with the second bit of the Codeblock or Transfer Frame, and so on.

1111 1111 0100 1000 0000 1110 1100 0000 1001 1010

6.5 LOGIC DIAGRAM

Figure 6-2 represents a possible generator for the specified sequence.

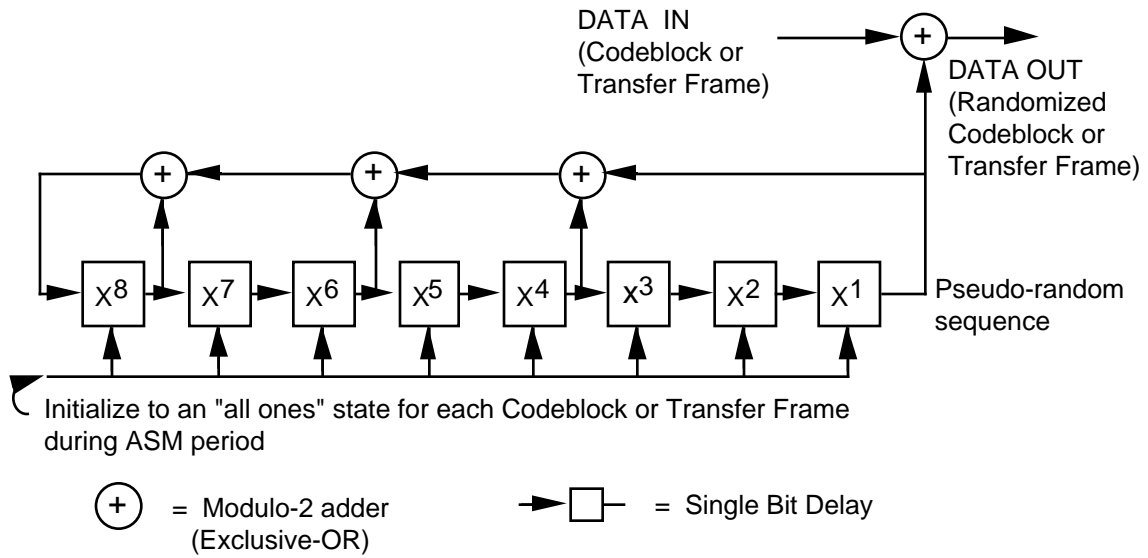

Figure 6-2: Pseudo-Randomizer Logic Diagram

ANNEX B

TRANSFORMATION BETWEEN BERLEKAMP AND CONVENTIONAL REPRESENTATIONS

(THIS ANNEX IS NOT PART OF THE RECOMMENDATION)

Purpose:

This Annex provides information to assist users of the Reed-Solomon code in this Recommendation to transform between the Berlekamp (dual basis) and Conventional representations. In addition, it shows where transformations are made to allow a conventional encoder to produce the dual basis representation on which the Recommendation is based.

CCSDS HISTORICAL DOCUMENT

CCSDS RECOMMENDATION FOR TELEMETRY CHANNEL CODING

Referring to Figure B-1, it can be seen that information symbols I entering and check symbols C emanating from the Berlekamp R-S encoder are interpreted as

$$[z_0, z_1, \dots, z_7]$$

where the components z_i are coefficients of ℓ_i , respectively:

$$z_0\ell_0 + z_1\ell_1 + \dots + z_7\ell_7$$

Information symbols I' entering and check symbols C' emanating from the conventional R-S encoder are interpreted as

$$[u_7, u_6, \dots, u_0]$$

where the components u_j are coefficients of α^j , respectively:

$$u_7\alpha^7 + u_6\alpha^6 + \dots + u_0$$

A pre- and post-transformation is required when employing a conventional R-S encoder.

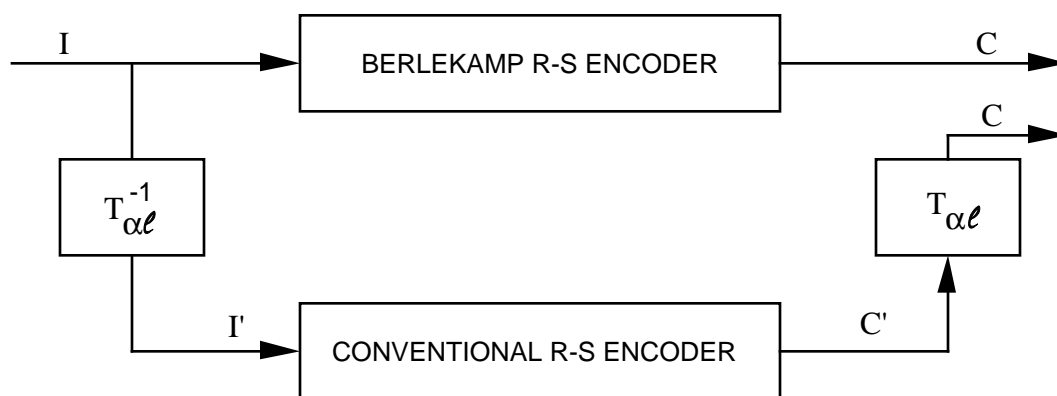

Figure B-1: Transformational Equivalence

Conventional and Berlekamp types of (255,223) Reed-Solomon encoders are assumed to have the same self-reciprocal generator polynomial whose coefficients appear in paragraph 4.2 (4) and (5). The representation of symbols associated with the conventional encoder is the polynomials in " α " appearing in Table B-1, below. Corresponding to each polynomial in " α " is the representation in the dual basis of symbols associated with the Berlekamp type encoder.

Given

$$\alpha^i = u_7\alpha^7 + u_6\alpha^6 + \dots + u_0$$

where $0 \leq i < 255$ (and α^* denotes the zero polynomial, $u_7, u_6, \dots = 0, 0, \dots$),

CCSDS HISTORICAL DOCUMENT

CCSDS RECOMMENDATION FOR TELEMETRY CHANNEL CODING

the corresponding element is

$$z = z_0\ell_0 + z_1\ell_1 + \dots + z_7\ell_7$$

where

$$[z_0, z_1, \dots, z_7] = [u_7, u_6, \dots, u_0] T_{\alpha\ell}$$

and

$$T_{\alpha\ell} = \begin{bmatrix} 1 & 0 & 0 & 0 & 1 & 1 & 0 & 1 \\ 1 & 1 & 1 & 0 & 1 & 1 & 1 & 1 \\ 1 & 1 & 1 & 0 & 1 & 1 & 0 & 0 \\ 1 & 0 & 0 & 0 & 0 & 1 & 1 & 0 \\ 1 & 1 & 1 & 1 & 1 & 0 & 1 & 0 \\ 1 & 0 & 0 & 1 & 1 & 0 & 0 & 1 \\ 1 & 0 & 1 & 0 & 1 & 1 & 1 & 1 \\ 0 & 1 & 1 & 1 & 1 & 0 & 1 & 1 \end{bmatrix}$$

Row 1, row 2, ..., and row 8 in $T_{\alpha\ell}$ are representations in the dual basis of α^7 (10 ... 0), α^6 (010 ... 0), ..., and α^0 (00 ... 01), respectively.

The inverse of $T_{\alpha\ell}$ is

$$T_{\alpha\ell}^{-1} = \begin{bmatrix} 1 & 1 & 0 & 0 & 0 & 1 & 0 & 1 \\ 0 & 1 & 0 & 0 & 0 & 0 & 1 & 0 \\ 0 & 0 & 1 & 0 & 1 & 1 & 1 & 0 \\ 1 & 1 & 1 & 1 & 1 & 1 & 0 & 1 \\ 1 & 1 & 1 & 1 & 0 & 0 & 0 & 0 \\ 0 & 1 & 1 & 1 & 1 & 0 & 0 & 1 \\ 1 & 0 & 1 & 0 & 1 & 1 & 0 & 0 \\ 1 & 1 & 0 & 0 & 1 & 1 & 0 & 0 \end{bmatrix}$$

Row 1, row 2, ..., and row 8 in $T_{\alpha\ell}^{-1}$ are polynomials in " α " corresponding to ℓ_0 (10 ... 0), ℓ_1 (010 ... 0), ..., and ℓ_7 (00, ... 01), respectively. Thus,

$$[z_0, z_1, \dots, z_7] T_{\alpha\ell}^{-1} = [u_7, u_6, \dots, u_0]$$

Example 1:

Given information symbol I,

$$[z_0, z_1, \dots, z_7] = 10111001$$

CCSDS HISTORICAL DOCUMENT

CCSDS RECOMMENDATION FOR TELEMETRY CHANNEL CODING

then

$$\begin{aligned}
 & T_{\alpha\ell}^{-1} \\
 [1\ 0\ 1\ 1\ 1\ 0\ 0\ 1] & \begin{bmatrix} 1 & 1 & 0 & 0 & 0 & 1 & 0 & 1 \\ 0 & 1 & 0 & 0 & 0 & 0 & 1 & 0 \\ 0 & 0 & 1 & 0 & 1 & 1 & 1 & 0 \\ 1 & 1 & 1 & 1 & 1 & 1 & 0 & 1 \\ 1 & 1 & 1 & 1 & 0 & 0 & 0 & 0 \\ 0 & 1 & 1 & 1 & 1 & 0 & 0 & 1 \\ 1 & 0 & 1 & 0 & 1 & 1 & 0 & 0 \\ 1 & 1 & 0 & 0 & 1 & 1 & 0 & 0 \end{bmatrix} = [u_7, u_6, \dots, u_0] = 00101010 = I'
 \end{aligned}$$

Note that the arithmetic operations are reduced modulo 2. Also,

$$[z_0, z_1, \dots, z_7] = 10111001$$

and

$$[u_7, u_6, \dots, u_0] = 00101010 (\alpha^{213})$$

are corresponding entries in Table B-1.

Example 2:

Given check symbol C',

$$[\alpha_7, \alpha_6, \dots, \alpha_0] = 01011001 (\alpha^{152})$$

Then,

$$\begin{aligned}
 [0\ 1\ 0\ 1\ 1\ 0\ 0\ 1] & \begin{bmatrix} 1 & 0 & 0 & 0 & 1 & 1 & 0 & 1 \\ 1 & 1 & 1 & 0 & 1 & 1 & 1 & 1 \\ 1 & 1 & 1 & 0 & 1 & 1 & 0 & 0 \\ 1 & 0 & 0 & 0 & 0 & 1 & 1 & 0 \\ 1 & 1 & 1 & 1 & 1 & 0 & 1 & 0 \\ 1 & 0 & 0 & 1 & 1 & 0 & 0 & 1 \\ 1 & 0 & 1 & 0 & 1 & 1 & 1 & 1 \\ 0 & 1 & 1 & 1 & 1 & 0 & 1 & 1 \end{bmatrix} = [z_0, z_1, \dots, z_7] = 11101000 = C
 \end{aligned}$$

CCSDS HISTORICAL DOCUMENT

CCSDS RECOMMENDATION FOR TELEMETRY CHANNEL CODING

Table B-1: Equivalence of Representations¹

P O W E R	POLY IN ALPHA	$\alpha_{01234567}$	P O W E R	POLY IN ALPHA	$\alpha_{01234567}$
=====					
*	00000000	00000000	31	11001101	01111010
0	00000001	01111011	32	00011101	10011110
1	00000010	10101111	33	00111010	00111111
2	00000100	10011001	34	01110100	00011100
3	00001000	11111010	35	11101000	01110100
4	00010000	10000110	36	01010111	00100100
5	00100000	11101100	37	10101110	10101101
6	01000000	11101111	38	11011011	11001010
7	10000000	10001101	39	00110001	00010001
8	10000111	11000000	40	01100010	10101100
9	10001001	00001100	41	11000100	11111011
10	10010101	11101001	42	00001111	10110111
11	10101101	01111001	43	00011110	01001010
12	11011101	11111100	44	00111100	00001001
13	00111101	01110010	45	01111000	01111111
14	01111010	11010000	46	11110000	<u>00001000</u>
15	11110100	10010001	47	01100111	01001110
16	01101111	10110100	48	11001110	10101110
17	11011110	00101000	49	00011011	10101000
18	00111011	01000100	50	00110110	01011100
19	01110110	10110011	51	01101100	01100000
20	11101100	11101101	52	11011000	00011110
21	01011111	11011110	53	00110111	00100111
22	10111110	00101011	54	01101110	11001111
23	11111011	00100110	55	11011100	10000111
24	01110001	11111110	56	00111111	11011101
25	11100010	00100001	57	01111110	01001001
26	01000011	00111011	58	11111100	01101011
27	10000110	10111011	59	01111111	00110010
28	10001011	10100011	60	11111110	11000100
29	10010001	01110000	61	01111011	10101011
30	10100101	10000011	62	11110110	00111110

¹ From Table 4 of Reference [4]. Note: Coefficients of the "Polynomial in Alpha" column are listed in descending powers of α , starting with α^7 .

CCSDS HISTORICAL DOCUMENT

CCSDS RECOMMENDATION FOR TELEMETRY CHANNEL CODING

Table B-1: Cont'd

P			P		
O	POLY		O	POLY	
W	IN	01234567	W	IN	01234567
E	ALPHA		E	ALPHA	
R			R		
=====					
63	01101011	00101101	95	10111010	10110010
64	11010110	11010010	96	11110011	11011100
65	00101011	11000010	97	01100001	01111000
66	01010110	01011111	98	11000010	11001101
<u>67</u>	10101100	<u>00000010</u>	99	00000011	11010100
68	11011111	01010011	100	00000110	00110110
69	00111001	11101011	101	00001100	01100011
70	01110010	00101010	102	00011000	01111100
71	11100100	00010111	103	00110000	01101010
72	01001111	01011000	104	01100000	00000011
73	10011110	11000111	105	11000000	01100010
74	10111011	11001001	106	00000111	01001101
75	11110001	01110011	107	00001110	11001100
76	01100101	11100001	108	00011100	11100101
77	11001010	00110111	109	00111000	10010000
78	00010011	01010010	110	01110000	10000101
79	00100110	11011010	111	11100000	10001110
80	01001100	10001100	112	01000111	10100010
81	10011000	11110001	113	10001110	01000001
82	10110111	10101010	114	10011011	00100101
83	11101001	00001111	115	10110001	10011100
84	01010101	10001011	116	11100101	01101100
85	10101010	00110100	117	01001101	11110111
86	11010011	00110000	118	10011010	01011110
87	00100001	10010111	119	10110011	00110011
<u>88</u>	01000010	<u>01000000</u>	120	11100001	11110101
89	10000100	00010100	121	01000101	00001101
90	10001111	00111010	122	10001010	11011000
91	10011001	10001010	123	10010011	11011111
92	10110101	00000101	124	10100001	00011010
93	11101101	10010110	<u>125</u>	11000101	<u>10000000</u>
94	01011101	01110001	126	00001101	00011000

CCSDS HISTORICAL DOCUMENT

CCSDS RECOMMENDATION FOR TELEMETRY CHANNEL CODING

Table B-1: Cont'd

P			P		
O	POLY		O	POLY	
W	IN	01234567	W	IN	01234567
E	ALPHA		E	ALPHA	
R			R		
=====					
127	00011010	11010011	159	10000101	01101111
128	00110100	11110011	160	10001101	10010101
129	01101000	11111001	161	10011101	00010011
130	11010000	11100100	162	10111101	11111111
131	00100111	10100001	<u>163</u>	11111101	<u>00010000</u>
132	01001110	00100011	164	01111101	10011101
133	10011100	01101000	165	11111010	01011101
134	10111111	01010000	166	01110011	01010001
135	11111001	10001001	167	11100110	10111000
136	01110101	01100111	168	01001011	11000001
137	11101010	11011011	169	10010110	00111101
138	01010011	10111101	170	10101011	01001111
139	10100110	01010111	171	11010001	10011111
140	11001011	01001100	172	00100101	00001110
141	00010001	11111101	173	01001010	10111010
142	00100010	01000011	174	10010100	10010010
143	01000100	01110110	175	10101111	11010110
144	10001000	01110111	176	11011001	01100101
145	10010111	01000110	177	00110101	10001000
146	10101001	11100000	178	01101010	01010110
147	11010101	00000110	179	11010100	01111101
148	00101101	11110100	180	00101111	01011011
149	01011010	00111100	181	01011110	10100101
150	10110100	01111110	182	10111100	10000100
151	11101111	00111001	183	11111111	10111111
152	01011001	11101000	<u>184</u>	01111001	<u>00000100</u>
153	10110010	01001000	185	11110010	10100111
154	11100011	01011010	186	01100011	11010111
155	01000001	10010100	187	11000110	01010100
156	10000010	00100010	188	00001011	00101110
157	10000011	01011001	189	00010110	10110000
158	10000001	11110110	190	00101100	10001111

CCSDS HISTORICAL DOCUMENT

CCSDS RECOMMENDATION FOR TELEMETRY CHANNEL CODING

Table B-1: Concluded

P			P		
O	POLY		O	POLY	
W	IN	01234567	W	IN	01234567
E	ALPHA		E	ALPHA	
R			R		
=====					
191	01011000	10010011	223	01100100	10011010
192	10110000	11100111	224	11001000	10011000
193	11100111	11000011	225	00010111	11001011
194	01001001	01101110	226	00101110	<u>00100000</u>
195	10010010	10100100	227	01011100	00001010
196	10100011	10110101	228	10111000	00011101
197	11000001	00011001	229	11110111	01000101
198	00000101	11100010	230	01101001	10000010
199	00001010	01010101	231	11010010	01001011
200	00010100	00011111	232	00100011	00111000
201	00101000	00010110	233	01000110	11011001
202	01010000	01101001	234	10001100	11101110
203	10100000	01100001	235	10011111	10111100
204	11000111	00101111	236	10111001	01100110
205	00001001	10000001	237	11110101	11101010
206	00010010	00101001	238	01101101	00011011
207	00100100	01110101	239	11011010	10110001
208	01001000	00010101	240	00110011	10111110
209	10010000	00001011	241	01100110	00110101
210	10100111	00101100	242	11001100	<u>00000001</u>
211	11001001	11100011	243	00011111	00110001
212	00010101	01100100	244	00111110	10100110
213	00101010	10111001	245	01111100	11100110
214	01010100	11110000	246	11111000	11110010
215	10101000	10011011	247	01110111	11001000
216	11010111	10101001	248	11101110	01000010
217	00101001	01101101	249	01011011	01000111
218	01010010	11000110	250	10110110	11010001
219	10100100	11111000	251	11101011	10100000
220	11001111	11010101	252	01010001	00010010
221	00011001	00000111	253	10100010	11001110
222	00110010	11000101	254	11000011	10110110

ANNEX C

EXPANSION OF REED-SOLOMON COEFFICIENTS

(THIS ANNEX IS NOT PART OF THE RECOMMENDATION)

Purpose:

While the equations given in the Reed-Solomon Coding Section of this recommendation are fully specifying, this Annex provides additional assistance for those implementing the code.

CCSDS HISTORICAL DOCUMENT

CCSDS RECOMMENDATION FOR TELEMETRY CHANNEL CODING

COEFFICIENTS OF $g(x)$	POLYNOMIAL IN α							
	α^7	α^6	α^5	α^4	α^3	α^2	α^1	α^0
$G_0 = G_{32} = \alpha^0$	0	0	0	0	0	0	0	1
$G_1 = G_{31} = \alpha^{249}$	0	1	0	1	1	0	1	1
$G_2 = G_{30} = \alpha^{59}$	0	1	1	1	1	1	1	1
$G_3 = G_{29} = \alpha^{66}$	0	1	0	1	0	1	1	0
$G_4 = G_{28} = \alpha^4$	0	0	0	1	0	0	0	0
$G_5 = G_{27} = \alpha^{43}$	0	0	0	1	1	1	1	0
$G_6 = G_{26} = \alpha^{126}$	0	0	0	0	1	1	0	1
$G_7 = G_{25} = \alpha^{251}$	1	1	1	0	1	0	1	1
$G_8 = G_{24} = \alpha^{97}$	0	1	1	0	0	0	0	1
$G_9 = G_{23} = \alpha^{30}$	1	0	1	0	0	1	0	1
$G_{10} = G_{22} = \alpha^3$	0	0	0	0	1	0	0	0
$G_{11} = G_{21} = \alpha^{213}$	0	0	1	0	1	0	1	0
$G_{12} = G_{20} = \alpha^{50}$	0	0	1	1	0	1	1	0
$G_{13} = G_{19} = \alpha^{66}$	0	1	0	1	0	1	1	0
$G_{14} = G_{18} = \alpha^{170}$	1	0	1	0	1	0	1	1
$G_{15} = G_{17} = \alpha^5$	0	0	1	0	0	0	0	0
$G_{16} = \alpha^{24}$	0	1	1	1	0	0	0	1

Note that $G_3 = G_{29} = G_{13} = G_{19}$.

Further information, including encoder block diagrams, is provided by Perlman and Lee in Reference [4].

ANNEX D

GLOSSARY OF TERMS

(THIS ANNEX IS NOT PART OF THE RECOMMENDATION)

Purpose:

This Annex provides definitions for many of the technical terms used in the Recommendation to help clarify their meaning among users and reduce the possibility of misunderstanding among multinational implementers.

GLOSSARY OF TERMS

BINARY SYMMETRIC CHANNEL (BSC):

A channel through which it is possible to send one binary digit per unit of time and for which there is a probability p ($0 < p < 1/2$) that the output is different from the input. This probability does not depend on whether the input is a zero or a one. Successive input digits are affected by the channel independently.

BLOCK ENCODING:

A one-to-one transformation of sequences of length k of elements of a source alphabet to sequences of length n of elements of a code alphabet, $n > k$.

CHANNEL SYMBOL:

The unit of output of the innermost encoder.

CODEBLOCK:

A codeblock of an (n,k) block code is a sequence of n channel symbols which were produced as a unit by encoding a sequence of k information symbols, and will be decoded as a unit.

CODE RATE:

The average ratio of the number of binary digits at the input of an encoder to the number of binary digits at its output.

CODEWORD:

In a block code, one of the sequences in the range of the one-to-one transformation (see **Block Encoding**).

CONCATENATION:

The use of two or more codes to process data sequentially with the output of one encoder used as the input of the next.

CCSDS HISTORICAL DOCUMENT

CCSDS RECOMMENDATION FOR TELEMETRY CHANNEL CODING

CONNECTION VECTOR:

In convolutional coding, a device used to specify one of the parity checks to be performed on the shift register in the encoder. For a binary constraint length k convolutional code, a connection vector is a k -bit binary number. A "one" in position i (counted from the left) indicates that the output of the i^{th} stage of the shift register is to be used in computing that parity check.

CONSTRAINT LENGTH:

In convolutional coding, the number of consecutive input bits that are needed to determine the value of the output symbols at any time.

CONVOLUTIONAL CODE:

As used in this document, a code in which a number of output symbols are produced for each input information bit. Each output symbol is a linear combination of the current input bit as well as some or all of the previous $k-1$ bits where k is the constraint length of the code.

GF(n):

The Galois Field consisting of exactly "n" elements.

INNER CODE:

In a concatenated coding system, the last encoding algorithm that is applied to the data stream. The data stream here consists of the codewords generated by the outer decoder.

MODULATING WAVEFORM:

A way of representing data bits ("1" and "0") by a particular waveform.

NRZ-L:

A modulating waveform in which a data "one" is represented by one of two levels, and a data "zero" is represented by the other level.

CCSDS HISTORICAL DOCUMENT

CCSDS RECOMMENDATION FOR TELEMETRY CHANNEL CODING

NRZ-M:

A modulating waveform in which a data "one" is represented by a change in level and a data "zero" is represented by no change in level.

OUTER CODE:

In a concatenated coding system, the first encoding algorithm that is applied to the data stream.

REED-SOLOMON (R-S) SYMBOL:

A set of J bits that represents an element in $GF(2^J)$, the code alphabet of a J -bit Reed-Solomon code.

SYSTEMATIC CODE:

A code in which the input information sequence appears in unaltered form as part of the output codeword.

TRANSPARENT CODE:

A code that has the property that complementing the input of the encoder or decoder results in complementing the output.

VIRTUAL FILL:

In a systematic block code, a codeword can be divided into an information part and a parity (check) part. Suppose that the information part is N symbols long (a symbol is defined here to be an element of the code's alphabet) and that the parity part is M symbols long. A "shortened" code is created by taking only S ($S < N$) information symbols as input, appending a fixed string of length $N-S$ and then encoding in the normal way. This fixed string is called "fill". Since the fill is a predetermined sequence of symbols, it need not be transmitted over the channel. Instead, the decoder appends the same fill sequence before decoding. In this case, the fill is called "Virtual Fill". □