



CCSDS

The Consultative Committee for Space Data Systems

Recommendation for Space Data System Practices

**SPACECRAFT ONBOARD
INTERFACE SERVICES—
SUBNETWORK TEST
SERVICE**

RECOMMENDED PRACTICE

CCSDS 855.0-M-1

MAGENTA BOOK

December 2009

Recommendation for Space Data System Practices

**SPACECRAFT ONBOARD
INTERFACE SERVICES—
SUBNETWORK TEST
SERVICE**

RECOMMENDED PRACTICE

CCSDS 855.0-M-1

MAGENTA BOOK

December 2009

AUTHORITY

Issue:	Recommended Practice, Issue 1
Date:	December 2009
Location:	Washington, DC, USA

This document has been approved for publication by the Management Council of the Consultative Committee for Space Data Systems (CCSDS) and represents the consensus technical agreement of the participating CCSDS Member Agencies. The procedure for review and authorization of CCSDS documents is detailed in the *Procedures Manual for the Consultative Committee for Space Data Systems*, and the record of Agency participation in the authorization of this document can be obtained from the CCSDS Secretariat at the address below.

This document is published and maintained by:

CCSDS Secretariat
Space Communications and Navigation Office, 7L70
Space Operations Mission Directorate
NASA Headquarters
Washington, DC 20546-0001, USA

STATEMENT OF INTENT

The Consultative Committee for Space Data Systems (CCSDS) is an organization officially established by the management of its members. The Committee meets periodically to address data systems problems that are common to all participants, and to formulate sound technical solutions to these problems. Inasmuch as participation in the CCSDS is completely voluntary, the results of Committee actions are termed **Recommendations** and are not in themselves considered binding on any Agency.

CCSDS Recommendations take two forms: **Recommended Standards** that are prescriptive and are the formal vehicles by which CCSDS Agencies create the standards that specify how elements of their space mission support infrastructure shall operate and interoperate with others; and **Recommended Practices** that are more descriptive in nature and are intended to provide general guidance about how to approach a particular problem associated with space mission support. This **Recommended Practice** is issued by, and represents the consensus of, the CCSDS members. Endorsement of this **Recommended Practice** is entirely voluntary and does not imply a commitment by any Agency or organization to implement its recommendations in a prescriptive sense.

No later than five years from its date of issuance, this **Recommended Practice** will be reviewed by the CCSDS to determine whether it should: (1) remain in effect without change; (2) be changed to reflect the impact of new technologies, new requirements, or new directions; or (3) be retired or cancelled.

In those instances when a new version of a **Recommended Practice** is issued, existing CCSDS-related member Practices and implementations are not negated or deemed to be non-CCSDS compatible. It is the responsibility of each member to determine when such Practices or implementations are to be modified. Each member is, however, strongly encouraged to direct planning for its new Practices and implementations towards the later version of the Recommended Practice.

FOREWORD

This document is a technical **Recommended Practice** for use in developing flight and ground systems for space missions and has been prepared by the **Consultative Committee for Space Data Systems** (CCSDS). The *Subnetwork Test Service* described herein is intended for missions that are cross-supported between Agencies of the CCSDS, in the framework of the Spacecraft Onboard Interface Services (SOIS) CCSDS area.

This **Recommended Practice** specifies a service to be used by space missions to test communications functionality of the node subnetwork interface and to test connectivity within the subnetwork. The SOIS Subnetwork Test Service is a simple service which is provided by data link-specific mechanisms within the subnetwork layers. The service interface is only present in the data system invoking the service. The SOIS Subnetwork Test Service provides a common service interface regardless of the particular type of data link being used for communication.

Through the process of normal evolution, it is expected that expansion, deletion, or modification of this document may occur. This Recommended Practice is therefore subject to CCSDS document management and change control procedures, which are defined in the *Procedures Manual for the Consultative Committee for Space Data Systems*. Current versions of CCSDS documents are maintained at the CCSDS Web site:

<http://www.ccsds.org/>

Questions relating to the contents or status of this document should be addressed to the CCSDS Secretariat at the address indicated on page i.

At time of publication, the active Member and Observer Agencies of the CCSDS were:

Member Agencies

- Agenzia Spaziale Italiana (ASI)/Italy.
- British National Space Centre (BNSC)/United Kingdom.
- Canadian Space Agency (CSA)/Canada.
- Centre National d'Etudes Spatiales (CNES)/France.
- China National Space Administration (CNSA)/People's Republic of China.
- Deutsches Zentrum für Luft- und Raumfahrt e.V. (DLR)/Germany.
- European Space Agency (ESA)/Europe.
- Russian Federal Space Agency (RFSA)/Russian Federation.
- Instituto Nacional de Pesquisas Espaciais (INPE)/Brazil.
- Japan Aerospace Exploration Agency (JAXA)/Japan.
- National Aeronautics and Space Administration (NASA)/USA.

Observer Agencies

- Austrian Space Agency (ASA)/Austria.
- Belgian Federal Science Policy Office (BFSP0)/Belgium.
- Central Research Institute of Machine Building (TsNIIMash)/Russian Federation.
- Centro Tecnico Aeroespacial (CTA)/Brazil.
- Chinese Academy of Sciences (CAS)/China.
- Chinese Academy of Space Technology (CAST)/China.
- Commonwealth Scientific and Industrial Research Organization (CSIRO)/Australia.
- CSIR Satellite Applications Centre (CSIR)/Republic of South Africa.
- Danish National Space Center (DNSC)/Denmark.
- European Organization for the Exploitation of Meteorological Satellites (EUMETSAT)/Europe.
- European Telecommunications Satellite Organization (EUTELSAT)/Europe.
- Geo-Informatics and Space Technology Development Agency (GISTDA)/Thailand.
- Hellenic National Space Committee (HNSC)/Greece.
- Indian Space Research Organization (ISRO)/India.
- Institute of Space Research (IKI)/Russian Federation.
- KFKI Research Institute for Particle & Nuclear Physics (KFKI)/Hungary.
- Korea Aerospace Research Institute (KARI)/Korea.
- Ministry of Communications (MOC)/Israel.
- National Institute of Information and Communications Technology (NICT)/Japan.
- National Oceanic and Atmospheric Administration (NOAA)/USA.
- National Space Organization (NSPO)/Chinese Taipei.
- Naval Center for Space Technology (NCST)/USA.
- Scientific and Technological Research Council of Turkey (TUBITAK)/Turkey.
- Space and Upper Atmosphere Research Commission (SUPARCO)/Pakistan.
- Swedish Space Corporation (SSC)/Sweden.
- United States Geological Survey (USGS)/USA.

DOCUMENT CONTROL

Document	Title	Date	Status
CCSDS 855.0-M-1	Spacecraft Onboard Interface Services—Subnetwork Test Service, Recommended Practice, Issue 1	December 2009	Original issue

CONTENTS

<u>Section</u>	<u>Page</u>
1 INTRODUCTION.....	1-1
1.1 PURPOSE AND SCOPE OF THIS DOCUMENT	1-1
1.2 APPLICABILITY	1-1
1.3 RATIONALE.....	1-1
1.4 DOCUMENT STRUCTURE	1-1
1.5 CONVENTIONS AND DEFINITIONS.....	1-2
1.6 DOCUMENT NOMENCLATURE.....	1-4
1.7 REFERENCES	1-4
2 OVERVIEW	2-1
2.1 FUNCTION	2-1
2.2 CONTEXT.....	2-1
2.3 ASSUMPTIONS.....	2-2
2.4 QUALITY OF SERVICE.....	2-2
2.5 SECURITY	2-2
3 SUBNETWORK TEST SERVICE	3-1
3.1 SERVICE PARAMETERS	3-1
3.2 TEST SERVICE PRIMITIVES.....	3-2
4 MANAGEMENT INFORMATION BASE	4-1
4.1 OVERVIEW	4-1
4.2 SPECIFICATIONS.....	4-1
5 SERVICE CONFORMANCE STATEMENT PROFORMA.....	5-1
ANNEX A INFORMATIVE REFERENCES	A-1

Figure

1-1 Bit Numbering Convention.....	1-2
2-1 Subnetwork Test Service Context	2-1

1 INTRODUCTION

1.1 PURPOSE AND SCOPE OF THIS DOCUMENT

This document is one of a family of documents specifying the SOIS-compliant services to be provided by onboard subnetworks.

The purpose of this document is to define services and service interfaces provided by the SOIS Subnetwork Test Service. Its scope is to specify the service only and not to specify methods of providing the service over a variety of onboard data links.

This document conforms to the principles set out in the Spacecraft Onboard Interface Services Green Book (reference [A1]) and is intended to be applied together with it. The protocols which provide this service are to be documented for individual links, and this may be in the purview of individual missions, agencies, or CCSDS, depending on future circumstance.

1.2 APPLICABILITY

This document applies to any mission or equipment claiming to provide a CCSDS SOIS-compliant Subnetwork Test Service.

1.3 RATIONALE

SOIS provide service interface specifications in order to promote interoperability and development reuse via peer-to-peer and vertical standardisation.

1.4 DOCUMENT STRUCTURE

The document has five major sections:

- this section, containing administrative information, definitions and references;
- section 2, describing general concepts and assumptions;
- section 3, containing the Subnetwork Test Service specification;
- section 4, containing the Management Information Base (MIB) for the service;
- section 5, comprising a Service Conformance Statement Proforma.

In addition, annex A contains informative references.

1.5 CONVENTIONS AND DEFINITIONS

1.5.1 BIT NUMBERING CONVENTION AND NOMENCLATURE

In this document, the following convention is used to identify each bit in an N -bit field. The first bit in the field to be transmitted (i.e., the most left justified when drawing a figure) is defined to be ‘Bit 0’; the following bit is defined to be ‘Bit 1’ and so on up to ‘Bit $N-1$ ’. When the field is used to express a binary value (such as a counter), the Most Significant Bit (MSB) shall be the first transmitted bit of the field, i.e., ‘Bit 0’ (see figure 1-1).

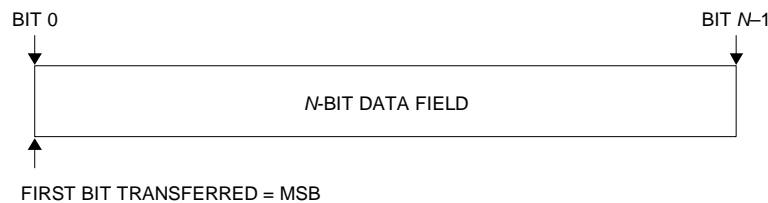

Figure 1-1: Bit Numbering Convention

In accordance with modern data communications practice, spacecraft data fields are often grouped into eight-bit ‘words’ widely known as bytes. Throughout this Recommended Practice, such an eight-bit word is called an ‘octet’.

The numbering for octets within a data structure starts with zero. By CCSDS convention, any ‘spare’ bits are permanently set to ‘0’.

1.5.2 DEFINITIONS

1.5.2.1 General

For the purpose of this document the following definitions apply.

1.5.2.2 Definitions from the Open Systems Interconnection (OSI) Basic Reference Model

This document is defined using the style established by the Open Systems Interconnection (OSI) Basic Reference Model (reference [A3]). This model provides a common framework for the development of standards in the field of systems interconnection.

The following terms, used in this Recommended Practice, are adapted from definitions given in reference [A3]:

layer: subdivision of the architecture, constituted by subsystems of the same rank.

protocol ID: identifier which uniquely identifies a SOIS Subnetwork user within a data system.

protocol data unit (PDU): unit of data specified in a protocol and consisting of Protocol Control Information (PCI) and possibly user data.

service: capability of a layer (service provider) together with the layers beneath it, which is provided to the service users.

subnetwork: an abstraction of a collection of equipment and physical media, such as a local area network or a data bus, which forms an autonomous whole and can be used to interconnect real systems for the purpose of data transfer.

test service access point (TSAP): the point at which SOIS test service is provided by a test service entity to a test service user entity.

test service access point address (TSAP Address): a test service address that is used to identify a single TSAP.

1.5.2.3 Terms Defined in this Recommended Practice

For the purposes of this Recommended Practice, the following definitions also apply. Many other terms that pertain to specific items are defined in the appropriate sections.

channel: identifier for subnetwork resources associated with a resource reservation.

NOTE – A channel can be a list of time slots in a time division multiplexed system or a bandwidth limit in a bandwidth division multiplexed system. The subnetwork resources required for the communication may also be defined to allow simultaneous use of non-conflicting resources on subnetworks that support this feature.

data system: addressable entity, situated in a subnet, which hosts an instance of the subnetwork protocols, subnetwork services, and subnetwork users.

NOTE – The subnetwork users are uniquely identifiable in a subnetwork by a combination of data system address and a protocol ID. A data system is typically a computer or a device.

data system address: identifier which uniquely identifies a data system in a subnetwork.

NOTE – The data system address can be referred to as a destination address or a source address depending on the context of its invocation at the subnetwork service interface.

octet: eight-bit word.

NOTE – An eight-bit word is commonly referred to as a byte.

priority: The transmit precedence of an SDU relative to other SDUs.

quality of service (QoS): ability of a communication system to provide predictable and differentiated services.

NOTE – Quality of service for a communication service can be characterised in terms of important features relevant to that communications service, for example: reliability, transmission rate, effective bandwidth and latency, error rate.

1.6 DOCUMENT NOMENCLATURE

The following conventions apply throughout this Recommended Practice:

- a) The words ‘shall’ and ‘must’ imply a binding and verifiable specification;
- b) The word ‘should’ implies an optional, but desirable, specification;
- c) The word ‘may’ implies an optional specification;
- d) The words ‘is’, ‘are’, and ‘will’ imply statements of fact.

1.7 REFERENCES

The following documents contain provisions which, through reference in this text, constitute provisions of this Recommended Practice. At the time of publication, the editions indicated were valid. All documents are subject to revision, and users of this Recommended Practice are encouraged to investigate the possibility of applying the most recent editions of the documents indicated below. The CCSDS Secretariat maintains a register of currently valid CCSDS Documents.

None.

NOTE – Informative references are contained in annex A.

2 OVERVIEW

2.1 FUNCTION

The SOIS Subnetwork Test Service provides a means for a user entity to test data system functionality and connectivity of the subnetwork.

2.2 CONTEXT

The SOIS Subnetwork Layer provides the Test Service to user applications. The service can be provided over a variety of data links, and the method of such provision is not in the scope of this document.

As shown in figure 2-1, the service is one of a number of services which can be provided by the SOIS Subnetwork.

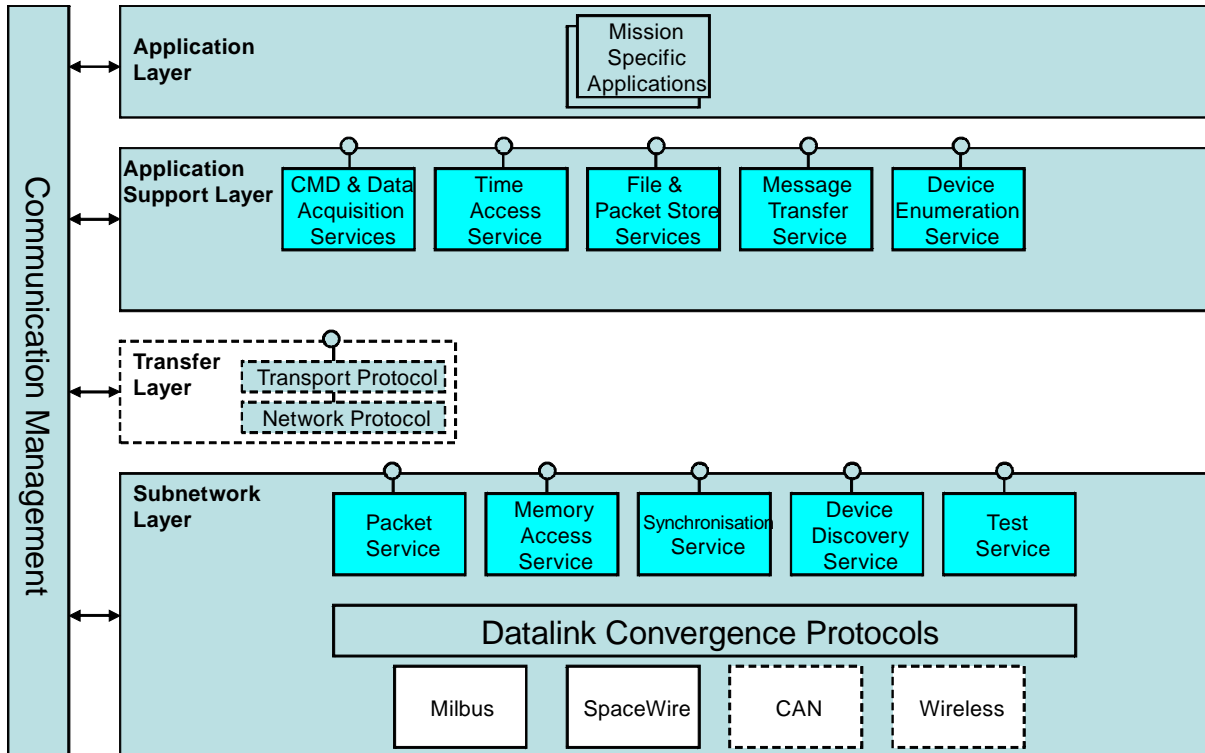

Figure 2-1: Subnetwork Test Service Context

The Subnetwork Test Service makes use of the data link to transfer data and control information. A variety of data links can be suited to provision of the service and the strategy for such service provision is outlined in reference [A1].

The Test Service is provided to the application entity invoking the service only. The method of testing is data-link specific.

2.3 ASSUMPTIONS

The following assumptions have been made in designing the SOIS Subnetwork Test Service:

- The SOIS Subnetwork Test Service is provided across single subnetworks.
- The SOIS Subnetwork Test Service is made available to protocol entities in the Transfer, Application Support, and User Application Layers.

2.4 QUALITY OF SERVICE

The Test Service operates with a single, Best-effort quality of service. This service makes a single attempt to provide the requested service but cannot ensure that it will be completed successfully.

Channel and Priority parameters are not provided in the Test Service. Were a subnetwork to provide channelisation or prioritisation to users of other subnetwork services, it would fall to the subnetwork Management Information Base (MIB) to set default channel and priority levels to ensure that the Test Service adhere to an overall subnetwork prioritisation and resource reservation scheme.

2.5 SECURITY

2.5.1 SECURITY BACKGROUND

The SOIS services are intended for use with protocols that operate solely within the confines of an onboard subnet. It is therefore assumed that SOIS services operate in an isolated environment which is protected from external threats. Any external communication is assumed to be protected by services associated with the relevant space-link protocols. The specification of such security services is outside the scope of this document.

2.5.2 SECURITY CONCERNS

At the time of writing there are no identified security concerns. If confidentiality of data is required within a spacecraft it is assumed it is applied at the Application layer. More information regarding the choice of service and where it can be implemented can be found in reference [A2].

2.5.3 POTENTIAL THREATS AND ATTACK SCENARIOS

Potential threats and attack scenarios typically derive from external communication and are therefore not the direct concern of the SOIS services which make the assumption that the services operate within a safe and secure environment. It is assumed that all applications executing within the spacecraft have been thoroughly tested and cleared for use by the mission implementer. Confidentiality of applications can be provided by Application layer

mechanisms or by specific implementation methods such as time and space partitioning. Such methods are outside the scope of SOIS.

2.5.4 CONSEQUENCES OF NOT APPLYING SECURITY

The security services are outside the scope of this document and are intended to be applied at layers above or below those specified in this document. If confidentiality is not implemented, science data or other parameters transmitted within the spacecraft might be visible to other applications resident within the spacecraft, resulting in disclosure of sensitive or private information.

3 SUBNETWORK TEST SERVICE

3.1 SERVICE PARAMETERS

3.1.1 GENERAL

The Subnetwork Test Service shall use the parameters specified in 3.1.2 to 3.1.4.

3.1.2 TEST SERVICE ACCESS POINT ADDRESS

The Test Service Access Point (TSAP) Address shall identify the SAP address that locates the user entity that wishes to invoke the Test Service.

3.1.3 TEST ADDRESS

- a) The Test Address parameter shall provide the subnetwork address of the data system whose status is to be verified.
- b) A Test Address identical to the subnetwork address of the data system hosting the TSAP shall be used to indicate that the subnetwork interface and subnetwork functionality local to the invoking application entity is to be verified. This provides a loop-back test capability.

3.1.4 TEST STATUS

- a) The Test Status parameter shall indicate the results of the test.

NOTE – The Test Service is intended to be used for checking data system functionality and connectivity of the subnetwork. The service is used to check operation of the subnetwork aspects of the local data system as well as subnetwork connectivity to other data systems.

- b) The status parameter may be dependent on the inherent capabilities of the Data Link layer protocol.
- c) As a minimum the service should return a go/no-go status.

NOTES

- 1 This can be augmented by error codes, bit rate selection, prime/redundant media active, etc.
- 2 The service does not indicate the correct operation of other subnetwork services but allows for the reporting of subnetwork-specific status.

3.2 TEST SERVICE PRIMITIVES

3.2.1 GENERAL

The SOIS Subnetwork Test Service shall use the following two primitives:

- a) **TEST.request** (which requests that a verification be performed), as specified in 3.2.2.
- b) **TEST.indication** (which returns the results of the verification), as specified in 3.2.3.

3.2.2 TEST.REQUEST

3.2.2.1 Function

The **TEST.request** primitive shall be used to request the service to perform a verification of subnetwork functionality.

3.2.2.2 Semantics

The **TEST.request** primitive shall use the following semantics, with the meaning of the parameters specified in 3.2.2.5:

TEST.request (TSAP Address, Test Address)

3.2.2.3 When Generated

The **TEST.request** primitive shall be passed to the SOIS Subnetwork Test Service provider to request that a verification be performed.

3.2.2.4 Effect on Receipt

Receipt of the **TEST.request** primitive shall cause the SOIS Subnetwork service provider to perform the verification.

3.2.2.5 Additional Comments

- a) The TSAP Address parameter shall identify the invoking user entity.
- b) The Test Address parameter shall identify the data system whose status is to be established.

NOTE – If the test address is identical to the address of the data system hosting the invoking user entity then status of the local subnetwork interface is requested.

3.2.3 TEST.INDICATION

3.2.3.1 Function

The **TEST.indication** shall be used to pass the results of the verification to the user entity.

3.2.3.2 Semantics

The **TEST.indication** primitive shall use the following semantics, with the meaning of the parameters specified in 3.2.3.5:

TEST.indication (TSAP Address, Test Address, Test Status)

3.2.3.3 When Generated

The **TEST.indication** primitive shall be issued by the service provider to the receiving application on receipt of subnetwork information pertaining to a verification.

3.2.3.4 Effect on Receipt

The response of the user entity to a **TEST.indication** primitive is unspecified.

3.2.3.5 Additional Comments

- a) The TSAP Address parameter shall identify the invoking user entity which is the recipient of the Test Status.
- b) The Test Address parameter shall identify the data system for which status was to be established.

NOTE – If the test address is identical to the address of the data system hosting the invoking user entity then status of the local subnetwork interface is requested.

- c) The Test Status parameter shall indicate the results of the verification. As a minimum, this shall be an indication of whether communication is possible with the device at the Test Address (the equivalent of an Internet “ping”). Other status information may also be carried in the Test Status parameter.

4 MANAGEMENT INFORMATION BASE

4.1 OVERVIEW

There is currently no Management Information Base (MIB) associated with this service. All management items are associated with the protocol providing the service. However, guidance is provided as to MIB contents in 4.3.

4.2 SPECIFICATIONS

Any protocol claiming to provide this service in a SOIS-compliant manner shall publish its MIB as part of the protocol specification.

4.3 MIB GUIDANCE

The MIB of the protocol providing the Test service should consider the following aspects:

- Test Status semantics;
- managed allocation of Test PDUs to:
 - priority,
 - channel.

NOTE – These aspects are not in any way an indication of the complete contents of a MIB for a protocol providing the Test service but are offered as guidance as to those aspects of the MIB which may relate to the Test service interface.

5 SERVICE CONFORMANCE STATEMENT PROFORMA

For any protocol specification claiming to provide this service, this proforma shall be completed, giving details of the capabilities of the specification, and made available to any party evaluating the use of the specification to which the completed proforma refers.

Service Conformance Statement SOIS Subnetwork Test Service

Implementation Information

Protocol Specification Identification	
Version	
Underlying Data Link	

Mandatory Features

TEST.request	√
TEST.indication	√

Additional Information

Indicate Supported Test Status Values	
---------------------------------------	--

ANNEX A

INFORMATIVE REFERENCES

- [A1] *Spacecraft Onboard Interface Services*. Report Concerning Space Data System Standards, CCSDS 850.0-G-1. Green Book. Issue 1. Washington, D.C.: CCSDS, June 2007.
- [A2] *The Application of CCSDS Protocols to Secure Systems*. Report Concerning Space Data System Standards, CCSDS 350.0-G-2. Green Book. Issue 2. Washington, D.C.: CCSDS, January 2006.
- [A3] *Information Technology—Open Systems Interconnection—Basic Reference Model: The Basic Model*. International Standard, ISO/IEC 7498-1:1994. 2nd ed. Geneva: ISO, 1994.

NOTE – Normative references are listed in 1.7.