

Report Concerning Space Data System Standards

**TM SYNCHRONIZATION
AND CHANNEL CODING—
SUMMARY OF CONCEPT
AND RATIONALE**

INFORMATIONAL REPORT

CCSDS 130.1-G-3

GREEN BOOK

June 2020

Report Concerning Space Data System Standards

**TM SYNCHRONIZATION
AND CHANNEL CODING—
SUMMARY OF CONCEPT
AND RATIONALE**

INFORMATIONAL REPORT

CCSDS 130.1-G-3

GREEN BOOK

June 2020

AUTHORITY

Issue:	Informational Report, Issue 3
Date:	June 2020
Location:	Washington, DC, USA

This document has been approved for publication by the Management Council of the Consultative Committee for Space Data Systems (CCSDS) and reflects the consensus of technical panel experts from CCSDS Member Agencies. The procedure for review and authorization of CCSDS Reports is detailed in *Organization and Processes for the Consultative Committee for Space Data Systems* (CCSDS A02.1-Y-4).

This document is published and maintained by:

CCSDS Secretariat
National Aeronautics and Space Administration
Washington, DC, USA
Email: secretariat@mailman.ccsds.org

FOREWORD

This document is a CCSDS Report that contains background and explanatory material to support the CCSDS Recommended Standard, *TM Synchronization and Channel Coding* (reference [3]).

Through the process of normal evolution, it is expected that expansion, deletion, or modification of this document may occur. This Report is therefore subject to CCSDS document management and change control procedures, which are defined in *Organization and Processes for the Consultative Committee for Space Data Systems* (CCSDS A02.1-Y-4). Current versions of CCSDS documents are maintained at the CCSDS Web site:

<http://www.ccsds.org/>

Questions relating to the contents or status of this document should be sent to the CCSDS Secretariat at the email address indicated on page i.

At time of publication, the active Member and Observer Agencies of the CCSDS were:

Member Agencies

- Agenzia Spaziale Italiana (ASI)/Italy.
- Canadian Space Agency (CSA)/Canada.
- Centre National d’Etudes Spatiales (CNES)/France.
- China National Space Administration (CNSA)/People’s Republic of China.
- Deutsches Zentrum für Luft- und Raumfahrt (DLR)/Germany.
- European Space Agency (ESA)/Europe.
- Federal Space Agency (FSA)/Russian Federation.
- Instituto Nacional de Pesquisas Espaciais (INPE)/Brazil.
- Japan Aerospace Exploration Agency (JAXA)/Japan.
- National Aeronautics and Space Administration (NASA)/USA.
- UK Space Agency/United Kingdom.

Observer Agencies

- Austrian Space Agency (ASA)/Austria.
- Belgian Federal Science Policy Office (BFSP0)/Belgium.
- Central Research Institute of Machine Building (TsNIIMash)/Russian Federation.
- China Satellite Launch and Tracking Control General, Beijing Institute of Tracking and Telecommunications Technology (CLTC/BITTT)/China.
- Chinese Academy of Sciences (CAS)/China.
- China Academy of Space Technology (CAST)/China.
- Commonwealth Scientific and Industrial Research Organization (CSIRO)/Australia.
- Danish National Space Center (DNSC)/Denmark.
- Departamento de Ciência e Tecnologia Aeroespacial (DCTA)/Brazil.
- Electronics and Telecommunications Research Institute (ETRI)/Korea.
- European Organization for the Exploitation of Meteorological Satellites (EUMETSAT)/Europe.
- European Telecommunications Satellite Organization (EUTELSAT)/Europe.
- Geo-Informatics and Space Technology Development Agency (GISTDA)/Thailand.
- Hellenic National Space Committee (HNSC)/Greece.
- Hellenic Space Agency (HSA)/Greece.
- Indian Space Research Organization (ISRO)/India.
- Institute of Space Research (IKI)/Russian Federation.
- Korea Aerospace Research Institute (KARI)/Korea.
- Ministry of Communications (MOC)/Israel.
- Mohammed Bin Rashid Space Centre (MBRSC)/United Arab Emirates.
- National Institute of Information and Communications Technology (NICT)/Japan.
- National Oceanic and Atmospheric Administration (NOAA)/USA.
- National Space Agency of the Republic of Kazakhstan (NSARK)/Kazakhstan.
- National Space Organization (NSPO)/Chinese Taipei.
- Naval Center for Space Technology (NCST)/USA.
- Research Institute for Particle & Nuclear Physics (KFKI)/Hungary.
- Scientific and Technological Research Council of Turkey (TUBITAK)/Turkey.
- South African National Space Agency (SANSA)/Republic of South Africa.
- Space and Upper Atmosphere Research Commission (SUPARCO)/Pakistan.
- Swedish Space Corporation (SSC)/Sweden.
- Swiss Space Office (SSO)/Switzerland.
- United States Geological Survey (USGS)/USA.

DOCUMENT CONTROL

Document	Title	Date	Status
CCSDS 130.1-G-1	TM Synchronization and Channel Coding—Summary of Concept and Rationale, Informational Report, Issue 1	June 2006	Original issue, superseded
CCSDS 130.1-G-2	TM Synchronization and Channel Coding—Summary of Concept and Rationale, Informational Report, Issue 2	November 2012	Issue 2, superseded
CCSDS 130.1-G-3	TM Synchronization and Channel Coding—Summary of Concept and Rationale, Informational Report, Issue 3	June 2020	Current issue

CONTENTS

<u>Section</u>	<u>Page</u>
1 DOCUMENT PURPOSE, SCOPE, AND ORGANIZATION	1-1
1.1 PURPOSE	1-1
1.2 SCOPE	1-1
1.3 ORGANIZATION	1-1
1.4 REFERENCES	1-2
2 OVERVIEW OF CCSDS TELEMETRY SYSTEM	2-1
2.1 INTRODUCTION	2-1
2.2 TELEMETRY SYSTEM CONCEPT	2-3
3 TM SYNCHRONIZATION AND CHANNEL CODING	3-1
3.1 INTRODUCTION	3-1
3.2 RECOMMENDED CODES	3-2
3.3 CHANNEL CODING PERFORMANCE	3-3
4 CONVOLUTIONAL CODES	4-1
4.1 INTRODUCTION	4-1
4.2 ENCODER FOR THE (7,1/2) RECOMMENDED CODE	4-1
4.3 ENCODER FOR THE RECOMMENDED PUNCTURED CONVOLUTIONAL CODES	4-3
4.4 SOFT MAXIMUM LIKELIHOOD DECODING OF CONVOLUTIONAL CODES	4-4
4.5 PERFORMANCE OF THE RECOMMENDED (7,1/2) CONVOLUTIONAL CODE	4-7
4.6 PERFORMANCE OF THE RECOMMENDED PUNCTURED CONVOLUTIONAL CODES	4-10
4.7 EFFECT OF THE TRUNCATION LENGTH ON PERFORMANCE	4-11
5 REED-SOLOMON CODE	5-1
5.1 INTRODUCTION	5-1
5.2 ENCODER	5-2
5.3 INTERLEAVING OF THE REED-SOLOMON SYMBOLS	5-4
5.4 HARD ALGEBRAIC DECODING OF REED-SOLOMON CODES	5-5
5.5 PERFORMANCE OF THE RECOMMENDED REED-SOLOMON CODES	5-6

CONTENTS (continued)

<u>Section</u>	<u>Page</u>
6 CONCATENATED CODES: REED-SOLOMON AND CONVOLUTIONAL	6-1
6.1 INTRODUCTION	6-1
6.2 ENCODING AND DECODING A CONCATENATED CODE	6-3
6.3 PERFORMANCE OF THE RECOMMENDED CONCATENATED CODING SYSTEMS	6-5
7 TURBO CODES.....	7-1
7.1 INTRODUCTION	7-1
7.2 TURBO ENCODER	7-2
7.3 TURBO DECODER	7-4
7.4 PERFORMANCE OF THE RECOMMENDED TURBO CODES	7-7
8 LDPC CODES.....	8-1
8.1 GENERAL.....	8-1
8.2 APPLICATIONS OF LDPC CODES.....	8-2
8.3 PARITY CHECK AND GENERATOR MATRICES FOR THE LDPC CODES	8-4
8.4 LDPC ENCODERS	8-6
8.5 LDPC DECODERS	8-8
8.6 PERFORMANCE OF THE RECOMMENDED LDPC CODES	8-9
8.7 IMPROVING PERFORMANCE IN THE ERROR FLOOR REGION	8-10
9 IMPORTANT ANCILLARY ASPECTS OF THE CODING SYSTEM.....	9-1
9.1 GENERAL.....	9-1
9.2 RANDOMIZATION OF THE CODED OUTPUT	9-1
9.3 FRAME SYNCHRONIZATION	9-7
9.4 CERTIFICATION OF THE DECODED DATA (FRAME INTEGRITY CHECKS).....	9-15
9.5 CODE TRANSPARENCY	9-21
9.6 REMAPPINGS OF THE BITS.....	9-22
ANNEX A GLOSSARY	A-1
ANNEX B ACRONYMS AND ABBREVIATIONS.....	B-1
ANNEX C QUANTIZATION STRATEGIES FOR SOFT-DECODING.....	C-1
ANNEX D RATIONALE FOR TURBO CODE PARAMETER SELECTIONS.....	D-1

CONTENTS (continued)

<u>Figure</u>	<u>Page</u>
2-1 Layered Telemetry Service Model	2-2
2-2 Telemetry Data Structures	2-5
3-1 Coding System Block Diagram: Concatenated Codes	3-2
3-2 Coding System Block Diagram: Turbo Codes	3-3
3-3 Capacity Limits on the BER Performance for Codes with Rates 1/2, 1/3, 1/4, and 1/6 Operating over a Binary Input AWGN Channel	3-4
3-4 Shannon Sphere-Packing Lower Bounds on the WER Performance for Codes with Varying Information Block Length k and Rates 1/6, 1/4, 1/3, 1/2, Operating over an Unconstrained-Input AWGN Channel	3-5
3-5 Performance Comparison of Selected Convolutional, Reed-Solomon, Concatenated, LDPC, and Turbo Codes	3-7
4-1 Example of Convolutional Encoder: Constraint Length $K=7$, Rate 1/2, CCSDS Standard Convolutional Code	4-2
4-2 Example of Serial-to-Parallel Conversion of the Convolutional Encoder Output for QPSK Modulation	4-3
4-3 Encoder Block Diagram for the Punctured CCSDS Convolutional Codes	4-4
4-4 (3,1/2) Convolutional Encoder	4-5
4-5 Trellis Representation of (3,1/2) Convolutional Code	4-5
4-6 Bit Error Rate Performance of the CCSDS Rate-1/2 Convolutional Code with Quantization Strategy 1 and Different Quantizers	4-7
4-7 Bit Error Rate Performance of the CCSDS Rate-1/2 Convolutional Code with Quantization Strategy 2 and Different Quantizers	4-8
4-8 Bit Error Rate Performance of the CCSDS Rate-1/2 Convolutional Code with Different Truncation Lengths D	4-9
4-9 Frame Error Rate Performance of the CCSDS Rate-1/2 Convolutional Code with Different Frame Lengths and Truncation Length $D=60$	4-9
4-10 Bit Error Rate Performance of the CCSDS Punctured Convolutional Codes	4-10
4-11 Frame Error Rate Performance of the CCSDS Punctured Convolutional Codes with Frame Length $L=8920$	4-11
4-12 Bit Error Rate Performance of the CCSDS Rate-5/6 Punctured Convolutional Code with Different Truncation Lengths D	4-12
4-13 Bit Error Rate Performance of the CCSDS Rate-7/8 Punctured Convolutional Code with Different Truncation Lengths D	4-12
5-1 Block Diagram of an (n,k) Reed-Solomon Encoder	5-3
5-2 RS Codeword Structure, $J=8$, $E=16$	5-3
5-3 Illustration of RS Codeword Structure, with and without Virtual Fill	5-4
5-4 Matrix Used for Interleaving	5-5
5-5 P_w , P_s , and P_b for the (255,223) RS Code with $E=16$	5-8
5-6 P_w , P_s , and P_b for the (255,239) RS Code with $E=8$	5-9

CONTENTS (continued)

<u>Figure</u>	<u>Page</u>
5-7 BER and WER Performance of the CCSDS $E=16$ Reed-Solomon Code (255,223): Simulated and Analytical Results for the AWGN Channel	5-9
5-8 BER and WER Performance of the CCSDS $E=8$ Reed-Solomon Code (255,239): Simulated and Analytical Results for the AWGN Channel	5-10
5-9 BER Performance Comparison of Shortened and Non-Shortened Reed-Solomon Codes on the AWGN Channel	5-10
6-1 Concatenated Coding System Block Diagram.....	6-1
6-2 Concatenated Coding System Block Diagram, Not CCSDS Compliant.....	6-2
6-3 Average Burst Length vs. SNR, at the Viterbi Decoder Output, $K=7$ CCSDS Convolutional Code.....	6-4
6-4 Performance of Concatenated Coding Systems with Ideal Interleaving, $E=16$, Punctured Codes	6-6
6-5 Performance of Concatenated Coding Systems with Ideal Interleaving, $E=8$, Punctured Codes	6-7
6-6 Performance of Concatenated Coding Systems with Ideal Interleaving, $E=16$ and $E=8$, Punctured Codes	6-8
6-7 Bit Error Rate Simulated Performance of the CCSDS Concatenated Scheme with Outer $E=16$ Reed-Solomon Code (255,223) and Inner Rate-1/2 Convolutional Code as a Function of Interleaving Depth	6-9
6-8 Word Error Rate Simulated Performance of the CCSDS Concatenated Scheme with Outer $E=16$ Reed-Solomon Code (255,223) and Inner Rate-1/2 Convolutional Code as a Function of Interleaving Depth	6-9
6-9 Bit Error Rate Simulated Performance of the CCSDS Concatenated Scheme with Outer $E=8$ Reed-Solomon Code (255,239) and Inner Rate-1/2 Convolutional Code as a Function of Interleaving Depth	6-10
6-10 Word Error Rate Simulated Performance of the CCSDS Concatenated Scheme with Outer $E=8$ Reed-Solomon Code (255,239) and Inner Rate-1/2 Convolutional Code as a Function of Interleaving Depth	6-10
6-11 Bit Error Rate Simulated Performance of the CCSDS Concatenated Scheme with Outer $E=16$ Reed-Solomon Code (255,223) and Inner Punctured Convolutional Codes, Using Finite Interleaving with $I=5$	6-11
6-12 Word Error Rate Simulated Performance of the CCSDS Concatenated Scheme with Outer $E=16$ Reed-Solomon Code (255,223) and Inner Punctured Convolutional Codes, Using Finite Interleaving with $I=5$	6-12
6-13 Bit Error Rate Simulated Performance of the CCSDS Concatenated Scheme with Outer $E=8$ Reed-Solomon Code (255,239) and Inner Punctured Convolutional Codes, Using Finite Interleaving with $I=5$	6-12
6-14 Word Error Rate Simulated Performance of the CCSDS Concatenated Scheme with Outer $E=8$ Reed-Solomon Code (255,239) and Inner Punctured Convolutional Codes, Using Finite Interleaving with $I=5$	6-13
7-1 Example of Turbo Encoder/Decoder	7-1

CONTENTS (continued)

<u>Figure</u>	<u>Page</u>
7-2 Block Diagram of Turbo Encoder	7-2
7-3 CCSDS Turbo Encoder Block Diagram	7-3
7-4 Structure of the Turbo Decoder	7-5
7-5 Basic Circuits to Implement the Log-APP Algorithm.....	7-6
7-6 BER and FER Performance for Rate 1/2, 1/4, 1/3, and 1/6 Turbo Codes with Block Size 1784 Bits, Measured from JPL DSN Turbo Decoder, 10 Iterations	7-8
7-7 BER and FER Performance for Rate 1/2, 1/4, 1/3, and 1/6 Turbo Codes with Block Size 3568 Bits, Software Simulation, 10 Iterations	7-8
7-8 BER and FER Performance for Rate 1/2, 1/4, 1/3, and 1/6 Turbo Codes with Block Size 7136 bits, Software Simulation, 10 Iterations.....	7-9
7-9 BER and FER Performance for Rate 1/2, 1/4, 1/3, and 1/6 Turbo Codes with Block Size 8920 Bits, Measured from JPL DSN Turbo Decoder, 10 Iterations	7-9
7-10 BER and FER Performance for Rate 1/2, 1/4, 1/3, and 1/6 Turbo Codes, Block Size 16384 Bits, Software Simulation, 10 Iterations	7-10
7-11 Illustration of Decoder Speedup Using Stopping Rules	7-10
7-12 BER Performance of Turbo Codes Compared to Older CCSDS Codes (Except Cassini/Pathfinder Code: Reed-Solomon (255,223) + (15,1/6) Convolutional Code), Block Size 1784 Bits (Interleaving Depth = 1), Software Simulation, 10 Iterations	7-12
7-13 BER Performance of Turbo Codes Compared to Older CCSDS Codes (Except Cassini/Pathfinder Code: Reed-Solomon (255,223) + (15,1/6) Convolutional Code), Block Size 8920 Bits (Interleaving Depth = 5), Software Simulation, 10 Iterations	7-13
7-14 Illustration of Turbo Code Error Floor	7-14
7-15 Performance of the (3568,1/6) Turbo Code with Erasures Either Uniformly Distributed or Grouped in a Single Burst	7-16
8-1 Power Efficiency versus Spectral Efficiency for Several CCSDS Codes	8-3
8-2 Power Efficiency versus Spectral Efficiency for Higher Order Modulations	8-4
8-3 Parity Check Matric for Code C2	8-4
8-4 Protographs for the AR4JA Code Family	8-5
8-5 Parity Check Matrix for the ($n=1280, k=1024$) AR4JA Code.....	8-6
8-6 One Encoder for Block-Circulant LDPC Codes.....	8-7
8-7 Another Encoder for Block-Circulant LDPC Codes	8-7
8-8 Bit Error Rate (Solid) and Frame Error Rate (Dashed) for Nine AR4JA Codes and C2, with Code Rates 1/2 (Red), 2/3 (Green), 4/5 (Blue), and 7/8 (Black); and Block Lengths $k=16384, 4096, 1024$ (Left to Right in Each Group), and 7156 (Code C2)	8-10
9-1 Block Diagram of the Recommended Pseudo-Randomizer	9-3
9-2 Turbo Codeword with Attached Sync Marker.....	9-9
9-3 A State-Diagram Based Frame Synchronizer.....	9-11

CONTENTS (continued)

<u>Figure</u>	<u>Page</u>
9-4 An Argmax Frame Synchronizer	9-12
9-5 Performance of Several Frame Synchronizers, Compared with Two Rate-1/2 LDPC Codes	9-14
9-6 CRC Encoding Principle.....	9-16
9-7 Logic Diagram of the Encoder.....	9-18
9-8 Logic Diagram of the Decoder	9-18
9-9 Turbo-CRC Encoder	9-19
9-10 Block Diagrams for Implementing the (Optional) (a) ‘NRZ-L to NRZ-M Conversion’ and (b) Its Inverse	9-22
C-1 Realization of Symmetric, Non-Uniform, Midrise Quantizer, $q = 4$	C-2
C-2 Quantization Law When Using the Quantization Strategy 2, for the Case of $q = 4$	C-2
C-3 Example of Comparison between Quantization Clipping Threshold 1 and Quantization Clipping Threshold 2, When Applied to CC+RS Concatenated Codes with $R = 1/2$ and $R = 7/8$	C-3
D-1 Comparison of Turbo Code Performance with Block Length-Constrained Lower Bound	D-2
D-2 Performance Comparison for Pseudo-Random and Algorithmic Permutations	D-4
D-3 Interpretation of Permutation.....	D-4
 <u>Table</u>	
4-1 Puncturing Patterns for the CCSDS Punctured Convolutional Code Rates	4-4
6-1 Frame Lengths for All Interleaving Depths.....	6-4

1 DOCUMENT PURPOSE, SCOPE, AND ORGANIZATION

1.1 PURPOSE

This report contains the concept and supporting rationale for *TM Synchronization and Channel Coding* developed by the Consultative Committee for Space Data Systems (CCSDS). It has been prepared to serve two major purposes:

- a) to provide an introduction and overview for the Channel Coding concept upon which the detailed CCSDS *TM Synchronization and Channel Coding* specifications (reference [3]) are based;
- b) to describe and explain the codes considered and to supply the supporting rationale.

Supporting performance information along with illustrations is also included. This report provides a broad tutorial overview of the CCSDS *TM Synchronization and Channel Coding* and is aimed at helping first-time readers to understand the Recommended Standard. It is not intended to provide all necessary knowledge for successfully designing telemetry communication links.

In no event will CCSDS or its members be liable for any incidental, consequential, or indirect damages, including any lost profits, lost savings, or loss of data, or for any claim by another party related to errors or omissions in this report. This document is a CCSDS informational Report and is therefore not to be taken as a CCSDS Recommended Standard. The actual Recommended Standard is in reference [3].

1.2 SCOPE

The concepts, protocols, and data formats developed for the *TM Synchronization and Channel Coding* described herein are designed for space communications links, primarily between spacecraft and ground elements. Data formats are designed with efficiency as a primary consideration; that is, format overhead is minimized. The results reflect the consensus of experts from many space agencies.

This document provides supporting and descriptive material only: **it is not part of the Recommended Standard**. In the event of any conflict between the *TM Synchronization and Channel Coding* Recommended Standard (reference [3]) and the material presented herein, the Recommended Standard shall prevail.

1.3 ORGANIZATION

An overview of the CCSDS Telemetry System is presented in section 2, which introduces the notion of architectural layering to achieve transparent and reliable delivery of scientific and engineering sensor data (generated aboard remote space vehicles) to the users located in space or on Earth.

Section 3 introduces the elements of Telemetry (TM) synchronization and channel coding and the specific codes considered in the CCSDS *TM Synchronization and Channel Coding Recommended Standard* (reference [3]).

Subsequent sections describe in detail the characteristics, performance, and rationale of the five classes of codes considered: convolutional, Reed-Solomon, concatenated, Turbo, and LDPC codes.

Annex A presents a Glossary in order to familiarize the reader with the terminology used throughout the CCSDS Telemetry System. Annex B is a list of acronyms and abbreviations. Annex C describes possible quantization strategies for soft-decision decoding. Annex D presents some rationale for Turbo code parameter selection.

1.4 REFERENCES

- [1] *Organization and Processes for the Consultative Committee for Space Data Systems*. Issue 4. CCSDS Record (Yellow Book), CCSDS A02.1-Y-4. Washington, D.C.: CCSDS, April 2014.
- [2] *TM Space Data Link Protocol*. Issue 2. Recommendation for Space Data System Standards (Blue Book), CCSDS 132.0-B-2. Washington, D.C.: CCSDS, September 2015.
- [3] *TM Synchronization and Channel Coding*. Issue 3. Recommendation for Space Data System Standards (Blue Book), CCSDS 131.0-B-3. Washington, D.C.: CCSDS, September 2017.
- [4] *Information Technology—Open Systems Interconnection—Basic Reference Model: The Basic Model*. 2nd ed. ISO/IEC 7498-1:1994. Geneva: ISO, 1994.
- [5] *AOS Space Data Link Protocol*. Issue 3. Recommendation for Space Data System Standards (Blue Book), CCSDS 732.0-B-3. Washington, D.C.: CCSDS, September 2015.
- [6] *Lossless Data Compression*. Issue 3. Report Concerning Space Data System Standards (Green Book), CCSDS 120.0-G-3. Washington, D.C.: CCSDS, April 2013.
- [7] *Space Packet Protocol*. Issue 2. Recommendation for Space Data System Standards (Blue Book), CCSDS 133.0-B-2. Washington, D.C.: CCSDS, June 2020.
- [8] C.E. Shannon. “A Mathematical Theory of Communication.” *Bell System Technical Journal* 27, no. 3 (July 1948): 379–423.
- [9] Joseph P. Odenwalder. “Concatenated Reed-Solomon/Viterbi Channel Coding for Advanced Planetary Missions: Analysis, Simulations, and Tests.” Final Report. Submitted to the Jet Propulsion Laboratory by Linkabit Corporation, San Diego, California, under Contract 953866, December 1, 1974.

- [10] K. Y. Liu. *The Effects of Receiver Tracking Phase Error on the Performance of Concatenated Reed-Solomon/Viterbi Channel Coding System*. JPL Publication 81-62. Pasadena, California: JPL, September 1, 1981.
- [11] J. P. Odenwalder, et al. “Hybrid Coding Systems Study.” Final Report. Submitted to NASA-Ames Research Center by Linkabit Corporation, San Diego, California, under Contract NAS2-6722, September 1972.
- [12] M. Perlman and J. J. Lee. *Reed-Solomon Encoders—Conventional vs. Berlekamp's Architecture*. JPL Publication 82-71. Pasadena, California: JPL, December 1, 1982.
- [13] U. Cheng. “Node Synchronization of Viterbi Decoders Using State Metrics.” *TDA Progress Report 42-94*, April–June 1988 (August 15, 1988): 201–209.
- [14] D. Divsalar and F. Pollara. “Turbo Codes for Deep-Space Communications.” *TDA Progress Report 42-120*, October–December 1994 (February 15, 1995): 29–39.
- [15] D. Divsalar, et al. “Transfer Function Bounds on the Performance of Turbo Codes.” *TDA Progress Report 42-122*, April–June 1995 (August 15, 1995): 44–55.
- [16] S. Dolinar, D. Divsalar, and F. Pollara. “Code Performance as a Function of Block Size.” *TMO Progress Report 42-133*, January–March 1998 (May 15, 1998): 1–23.
- [17] C. Berrou, A. Glavieux, and P. Thitimajshima. “Near Shannon Limit Error-Correcting Coding and Decoding: Turbo codes.” In *Proceedings of IEEE International Conference on Communications*, 1064–1070. Geneva: IEEE, 1993.
- [18] S. Benedetto, et al. “Soft-Output Decoding Algorithms in Iterative Decoding of Turbo Codes.” *TDA Progress Report 42-124*, October-December 1995 (February 15, 1996): 63-87.
- [19] S. Benedetto, et al. “A Soft-Input Soft-Output Maximum A Posteriori (MAP) Module to Decode Parallel and Serial Concatenated Codes.” *TDA Progress Report 42-127*, July-September 1996 (November 15, 1996): 1–20.
- [20] J. Hamkins and D. Divsalar. “Coupled Receiver-Decoders for Low Rate Turbo Codes.” In *Proceedings of IEEE International Symposium on Information Theory*, 381–381. Geneva: IEEE, 2003.
- [21] A. J. Viterbi and J. K. Omura. *Principles of Digital Communication and Coding*. New York: McGraw-Hill, 1979.
- [22] I. S. Reed and G. Solomon. “Polynomial Codes Over Certain Finite Fields.” *SIAM Journal on Applied Mathematics* 8, no. 2 (1960): 300–304.
- [23] R. J. McEliece and L. Swanson. “On the Decoder Error Probability for Reed-Solomon Codes.” *TDA Progress Report 42-84*, October-December 1985 (February 15, 1986): 66–72.

- [24] R. J. McEliece. “The Decoding of Reed-Solomon Codes.” *TDA Progress Report 42-95*, July-September 1988 (November 15, 1988): 153–157.
- [25] G. D. Forney, Jr. “The Viterbi Algorithm.” *Proceedings of the IEEE* 61, no. 3 (March 1973): 268–278.
- [26] G. D. Forney, Jr. *Concatenated Codes*. Cambridge: MIT Press, 1966.
- [27] R. L. Miller, L. J. Deutsch, and S. A. Butman. *On the Error Statistics of Viterbi Decoding and the Performance of Concatenated Codes*. JPL Publication 81-9. Pasadena, California: JPL, September 1, 1981.
- [28] K.-M. Cheung and S. J. Dolinar, Jr. “Performance of Galileo's Concatenated Codes With Nonideal Interleaving.” *TDA Progress Report 42-95*, July-September 1988 (November 15, 1988): 148–152.
- [29] D. Divsalar. “A Simple Tight Bound on Error Probability of Block Codes with Application to Turbo Codes.” *TMO Progress Report 42-139*, July-September 1999 (November 15, 1999): 1–35.
- [30] R. Garello, P. Pierleoni, and S. Benedetto. “Computing the Free Distance of Turbo Codes and Serially Concatenated Codes with Interleavers: Algorithms and Applications.” *Journal on Selected Areas in Communications* 19, no. 5 (May 2001): 800–812.
- [31] L. Deutsch, F. Pollara, and L. Swanson. “Effects of NRZ-M Modulation on Convolutional Codes Performance.” *TDA Progress Report 42-77*, January-March 1984 (May 15, 1984): 33–40.
- [32] Gian Paolo Calzolari, et al. “Turbo Code Applications on Telemetry and Deep Space Communications.” In *Turbo Code Applications: A Journey from a Paper to Realization*, edited by Keattisak Sripimanwat, 321–344. Dordrecht: Springer, 2005.
- [33] D.J.C. MacKay and R.M. Neal. “Near Shannon Limit Performance of Low Density Parity Check Codes.” *Electronics Letters* 32, no. 18 (August 1996): 1645–1646.
- [34] R. Gallager. “Low-Density Parity-Check Codes.” *IRE Transactions on Information Theory* 8, no. 1 (January 1962): 21–28.
- [35] T. J. Richardson, M. A. Shokrollahi, and R. L. Urbanke. “Design of Capacity-Approaching Irregular Low-Density Parity-Check Codes.” *IEEE Transactions on Information Theory* 47, no. 2 (February 2001): 619–637.
- [36] Y. Kou, S. Lin, and M. P. C. Fossorier. “Low-Density Parity-Check Codes Based on Finite Geometries: A Rediscovery and New Results.” *IEEE Transactions on Information Theory* 47, no. 7 (November 2001): 2711–2736.

- [37] W. Fong. “White Paper for Low Density Parity Check (LDPC) Codes for CCSDS Channel Coding Blue Book.” Presented at CCSDS Subpanel 1B Channel Coding Meeting (October 2002, Houston, Texas).
- [38] Z. Li, et al. “Efficient Encoding of Quasi-Cyclic Low-Density Parity-Check Codes.” *IEEE Transactions on Communications* 54, no. 1 (January 2006): 71–81.
- [39] J. Heo. “Analysis of Scaling Soft Information on Low Density Parity Check Code.” *Electronics Letters* 39, no. 2 (January 2003): 219–221.
- [40] Shu Lin and Daniel J. Costello, Jr. *Error Control Coding*. 2nd ed. Upper Saddle River, New Jersey: Prentice Hall, 2004.
- [41] K. Andrews, S. Dolinar, and J. Thorpe. “Encoders for Block-Circulant LDPC Codes.” In *Proceedings of the IEEE International Symposium on Information Theory (Adelaide, Australia)*, 2300–2304. Piscataway, New Jersey: IEEE, September 2005.
- [42] J. Lee and J. Thorpe. “Memory-Efficient Decoding of LDPC Codes.” In *Proceedings of the IEEE International Symposium on Information Theory (Adelaide, Australia)*, 459–463. Piscataway, New Jersey: IEEE, September 2005.
- [43] S. Dolinar and K. Andrews. “Performance and Decoder Complexity Estimates for Families of Low-Density Parity-Check Codes.” *IPN Progress Report* 42-168 (February 2007).
- [44] A. Abbasfar, D. Divsalar, and K. Yao. “Accumulate Repeat Accumulate Codes.” In *Proceedings of GLOBECOM '04 (Dallas, Texas)*, 1-509–1-513. Piscataway, New Jersey: IEEE, 29 Nov–3 Dec 2004.
- [45] D. Divsalar, S. Dolinar, and C. Jones. “Low-Rate LDPC Codes with Simple Protograph Structure.” In *Proceedings of the IEEE International Symposium on Information Theory (Adelaide, Australia)*, 1622–1626. Piscataway, New Jersey: IEEE, September 2005.
- [46] D. Divsalar, S. Dolinar, and C. Jones. “Construction of Protograph LDPC Codes with Linear Minimum Distance.” In *Proceedings of the IEEE International Symposium on Information Theory (Seattle, Washington)*. Piscataway, New Jersey: IEEE, July 2006.
- [47] S. A. Butman and R. J. McEliece. “The Ultimate Limits of Binary Coding for a Wideband Gaussian Channel.” *DSN Progress Report* 42-22, May-June 1974 (August 15, 1974): 78–80.
- [48] T. Tian, et al. “Selective Avoidance of Cycles in Irregular LDPC Code Construction.” *IEEE Transactions on Communications* 52, no. 8 (August 2004): 1242–1247.
- [49] Shu Lin, et al. “Quasi-Cyclic LDPC Codes.” Presented at CCSDS Coding and Synchronization Working Group Meeting (October 24, 2003, College Park, Maryland).

- [50] Dariush Divsalar, et al. Encoders for Block-Circulant LDPC Codes. US Patent 7499490, filed June 24, 2005, and issued March 3, 2009.
- [51] K. S. Andrews, et al. “The Development of Turbo and LDPC Codes for Deep-Space Applications.” *Proceedings of the IEEE* 95, no. 11 (November 2007): 2142–2156.
- [52] Sarah L. Sweatlock, Sam Dolinar, and Kenneth Andrews. “Buffering Requirements for Variable-Iterations LDPC Decoders.” In *2008 Information Theory and Applications Workshop (January 27–February 1, 2008, San Diego, California)*, 523–530. Piscataway, New Jersey: IEEE, 2008.
- [53] J. Massey. “Optimum Frame Synchronization.” *IEEE Transactions on Communications* 20, no. 2 (April 1972): 115–119.
- [54] Jon Hamkins. “Performance of Low-Density Parity-Check Coded Modulation.” *IPN Progress Report* 42-184, February 2011 (February 15, 2011).
- [55] *TC Space Data Link Protocol*. Issue 3. Recommendation for Space Data System Standards (Blue Book), CCSDS 232.0-B-3. Washington, D.C.: CCSDS, September 2015.
- [56] W. W. Peterson and D. T. Brown. “Cyclic Codes for Error Detection.” *Proceedings of the IRE* 49, no. 1 (January 1961): 228–235.
- [57] W. W. Peterson and E. J. Weldon. *Error-Correcting Codes*. 2nd ed. Cambridge: MIT Press, 1972.
- [58] T. G. Berry. “A Note on the Modified CRC.” *ACM SIGCOMM Computer Communication Review* 20, no. 5 (October 1990): 12–17.
- [59] D. Fiorini, et al. “Can We Trust in HDLC?” *ACM SIGCOMM Computer Communication Review* 24, no. 5 (October 1994): 61–80.
- [60] V. K. Agarwal and A. Ivanov. “Computing the Probability of Undetected Error for Shortened Cyclic Codes.” *IEEE Transactions on Communications* 40, no. 3 (March 1992): 494–499.
- [61] J. K. Wolf and D. Chun. “The Single Burst Error Detection Performance of Binary Cyclic Codes.” *IEEE Transactions on Communications* 42, no. 1 (January 1994): 11–13.
- [62] O. Alvarez and G. Lesthievant. “Pseudo-Random Codes for High Data Rate Telemetry: Analysis and New Proposal.” Presented at Joint Meeting of the CCSDS RF & Modulation and Coding and Synchronization Working Groups (June 12, 2006, Rome, Italy).
- [63] “Terrestrial and Space Services Sharing Frequency Bands above 1 GHz.” In *Radio Regulations—Volume I: Articles*, 251–261. Edition of 2004. RR21-1. Geneva: ITU, 2004.
- [64] *Space Engineering: Radio Frequency and Modulation*. Rev. 1. ECSS-E-ST-50-05C. Noordwijk, The Netherlands: ECSS Secretariat, March 2009.

- [65] R. Garelo, M. Baldi, and F. Chiaraluce. *Randomizer for High Data Rates*. ESA Contract Report, ESOC Contract No. 20959/07/D/MRP. Darmstadt, Germany: ESA/ESOC, March 2009.
- [66] M. Baldi, et al. “On the Autocorrelation Properties of Truncated Maximum-Length Sequences and Their Effect on the Power Spectrum.” *IEEE Transactions on Signal Processing* 58, no. 12 (December 2010): 6284-6297.
- [67] M. Chiani and M. Martini. “Analysis of Optimum Frame Synchronization Based on Periodically Embedded Sync Words.” *IEEE Transactions on Communications* 55, no. 11 (November 2007): 2056–2060.
- [68] David R. Smith. *Digital Transmission Systems*. 3rd ed. Norwell, Massachusetts: Kluwer, 2003.
- [69] M. Chiani. “Noncoherent Frame Synchronization.” *IEEE Transactions on Communications* 58, no. 5 (May 2010): 1536–1545.
- [70] B. Moision. “A Truncation Depth Rule of Thumb for Convolutional Codes.” In *Proceedings of the Information Theory and Applications Workshop (January 27 2008-February 1 2008, San Diego, California)*, 555–557. New York: IEEE, 2008.
- [71] J. Lee, R. Urbanke, and R. Blahut. “Turbo Codes in Binary Erasure Channel.” *IEEE Transactions on Information Theory* 54, no. 4 (April 2008): 1765–1773.
- [72] E. Rosnes and O. Ytrehus. “Turbo Decoding on the Binary Erasure Channel: Finite-Length Analysis and Turbo Stopping Sets.” *IEEE Transactions on Information Theory* 53, no. 11 (November 2007): 4059–4075.

The latest issues of CCSDS documents may be obtained from the CCSDS Secretariat at the address indicated on page i.

2 OVERVIEW OF CCSDS TELEMETRY SYSTEM

2.1 INTRODUCTION

The purpose of a telemetry system is to reliably and transparently convey measurement information from a remotely located data generating source to users located in space or on Earth. Typically, data generators are scientific sensors, science housekeeping sensors, engineering sensors, and other subsystems on board a spacecraft.

The advent of capable microprocessor-based hardware will result in data systems with demands for greater throughput and a requirement for corresponding increases in spacecraft autonomy and mission complexity. These facts, along with the current technical and administrative environments, create a need for greater telemetering capability and efficiency with reduced costs.

In the past, most of the telemetry resources used by a science mission have been wholly contained within a cognizant Project office and, with the exception of the tracking network, are completely dedicated to that mission. The lack of effective standardization among various missions forces the ‘multi-mission’ tracking network to implement the lowest level of telemetry transport service, that is, bit transport. Higher level data delivery services, oriented more toward computer-to-computer transfers and typical of modern day commercial and military networks, have to be custom designed and implemented on a mission-to-mission basis.

The intent of the CCSDS Telemetry System is not only to ease the transition toward greater automation within individual space agencies, but also to ensure harmony among the agencies, thereby resulting in greater cross-support opportunities and services.

The CCSDS Telemetry System is broken down into two major conceptual categories: a ‘TM Space Data Link Protocol’ concept (references [2] and [7]) and a ‘TM Synchronization and Channel Coding’ concept (reference [3]).

- a) *TM Space Data Link Protocol* is a concept that facilitates the transfer of space-acquired data from source to user in a standardized and highly automated manner. TM Space Data Link Protocol provides a mechanism for implementing common data structures and protocols that can enhance the development and operation of space mission systems. TM Space Data Link Protocol addresses the following two processes:
 - 1) The end-to-end transport of space mission data sets from source application processes located in space to distributed user application processes located in space or on Earth.
 - 2) The intermediate transfer of these data sets through space data networks; more specifically, those elements that contain spacecraft, radio links, tracking stations and mission control centers as some of their components.

The *TM Space Data Link Protocol* Recommended Standard contained in references [2] and [7] is primarily concerned with describing the telemetry formats that are generated by spacecraft in order to execute their roles in the above processes.

- b) *TM Synchronization and Channel Coding* (reference [3]) is a method by which data can be sent from a source to a destination by processing it in such a way that distinct messages are created that are easily distinguishable from one another. This allows reconstruction of the data with low error probability, thus improving the performance of the channel. The *TM Synchronization and Channel Coding* Recommended Standard contained in reference [3] describes several space TM Synchronization and Channel Coding schemes. The characteristics of the codes are specified only to the extent necessary to ensure interoperability and cross-support.

Together, TM Space Data Link Protocol and TM Synchronization and Channel Coding services provide to the user reliable and transparent delivery of telemetry information.

Figure 2-1 illustrates the CCSDS Telemetry System in terms of a layered service model. It should be noted that the CCSDS *TM Space Data Link Protocol* and *TM Synchronization and Channel Coding* Recommended Standards only address the five lower layers of this model.

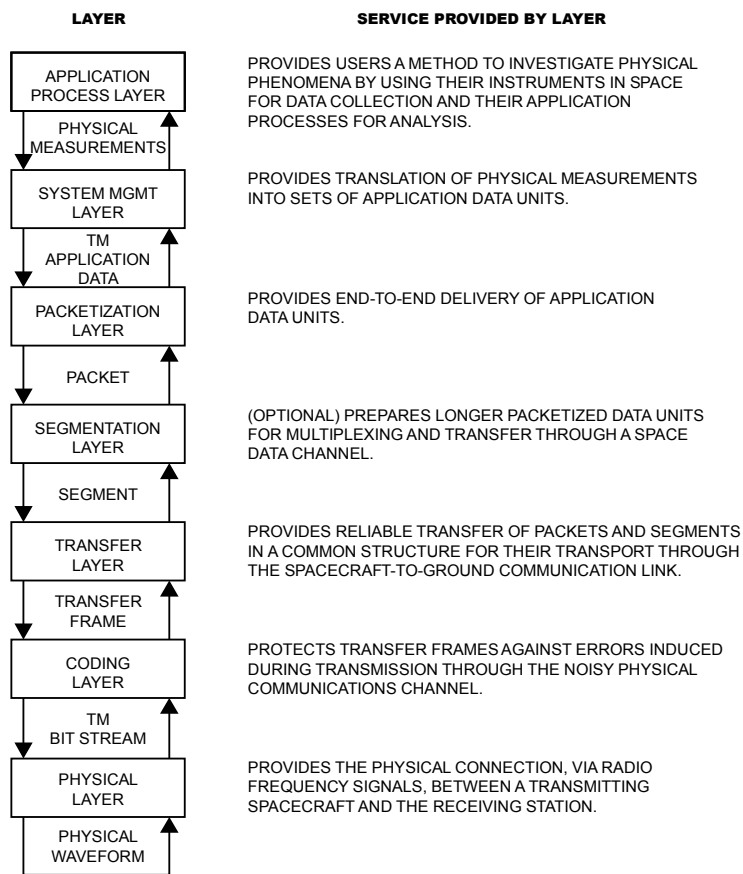

Figure 2-1: Layered Telemetry Service Model

2.2 TELEMETRY SYSTEM CONCEPT

2.2.1 GENERAL

The system design technique known as layering was found to be a very useful tool for transforming the Telemetry System concept into sets of operational and formatting procedures. The layering approach is patterned after the International Organization for Standardization's Open Systems Interconnection layered network model (reference [4]), which is a seven-layer architecture that groups functions logically and provides conventions for connecting functions at each layer. Layering allows a complex procedure such as the telemetering of spacecraft data to the users to be decomposed into sets of peer functions residing in common architectural strata.

Within each layer, the functions exchange data according to established standard rules or 'protocols'. Each layer draws upon a well-defined set of services provided by the layer below, and provides a similarly well-defined set of services to the layer above. As long as these service interfaces are preserved, the internal operations within a layer are unconstrained and transparent to other layers. Therefore, an entire layer within a system may be removed and replaced as dictated by user or technological requirements without destroying the integrity of the rest of the system. Further, as long as the appropriate interface protocol is satisfied, a customer (user) can interact with the system/service at any of the component layers. Layering is therefore a powerful tool for designing structured systems that change as a result of the evolution of requirements or technology.

A companion standardization technique that is conceptually simple, yet very robust, is the encapsulation of data within an envelope or 'header'. The header contains the identifying information needed by the layer to provide its service while maintaining the integrity of the envelope contents.

2.2.2 PACKETIZATION LAYER

Within *TM Space Data Link Protocol*, spacecraft generated application data are formatted into end-to-end transportable data units called 'TM Source Packets'. These data are encapsulated within a primary header that contains identification, sequence control, and packet length information. A TM Source Packet is the basic data unit telemetered to the user by the spacecraft and generally contains a meaningful quantity of related measurements from a particular source.

2.2.3 TRANSFER FRAME LAYER

The *TM Transfer Frame* is used to reliably transport Source Packets (and Segments) through the telemetry channel to the receiving telecommunications network. As the heart of the CCSDS Telemetry System, the TM Transfer Frame protocols offer a range of delivery service options. An example of such a service option is the multiplexing of TM Transfer Frames into Virtual Channels (VCs).

The TM Transfer Frame is a fixed-length unit that was chosen to improve the ability to synchronize the frame with weak signals such as those found on space-ground links, and for compatibility with certain block-oriented channel coding schemes. The (primary) header contains frame identification, channel frame count information, and frame data field status information. An Attached Synchronization Marker (ASM) signals the start of the TM Transfer Frame.

The Transfer Frame *data field* may be followed by an optional trailer containing an operational control field and/or a frame error control field. The first of these fields provides a standard mechanism for incorporating a small number of real-time functions (e.g., telecommand verification or spacecraft clock calibration). The error control field provides the capability for detecting errors that may have been introduced into the frame during the data handling process.

The delivery of Transfer Frames requires the services provided by the lower layers (e.g., carrier, modulation/detection, and coding/decoding) to accomplish its role.

2.2.4 CHANNEL CODING LAYER

TM Synchronization and Channel Coding is used to protect the Transfer Frames against telemetry channel noise-induced errors. Reference [3] describes the CCSDS Recommended Standard for *TM Synchronization and Channel Coding*, including specification of a convolutional code, a Reed-Solomon (RS) block-oriented code, a concatenated coding system consisting of a convolutional inner code and an RS outer code, Turbo codes, and LDPC codes. The basic data units of the CCSDS TM Synchronization and Channel Coding, which interface with the physical layer below, are the Channel Symbols output by the channel encoder.

The RF channel physically modulates the channel symbols into RF signal patterns. Within the error detecting and correcting capability of the channel code chosen, errors that occur as a result of the physical transmission process may be detected and corrected by the receiving entity.

Full advantage of all CCSDS Telemetry System services could be realized if a Project complied with all CCSDS Recommended Standards. Alternatively, Projects can interface with any layer of the Telemetry System as long as they meet the interface requirements as specified in the Recommended Standards (references [2], [3], and [5]).

Figure 2-2 illustrates how the various telemetry data structures map into one another. There is presently no attempt to define the data structures of the top two layers of the telemetry system, that is, the Application Process layer and the System Management layer. The Source Packets are placed into the data field of the Transfer Frame. An ASM is always used, as shown in figure 2-2.

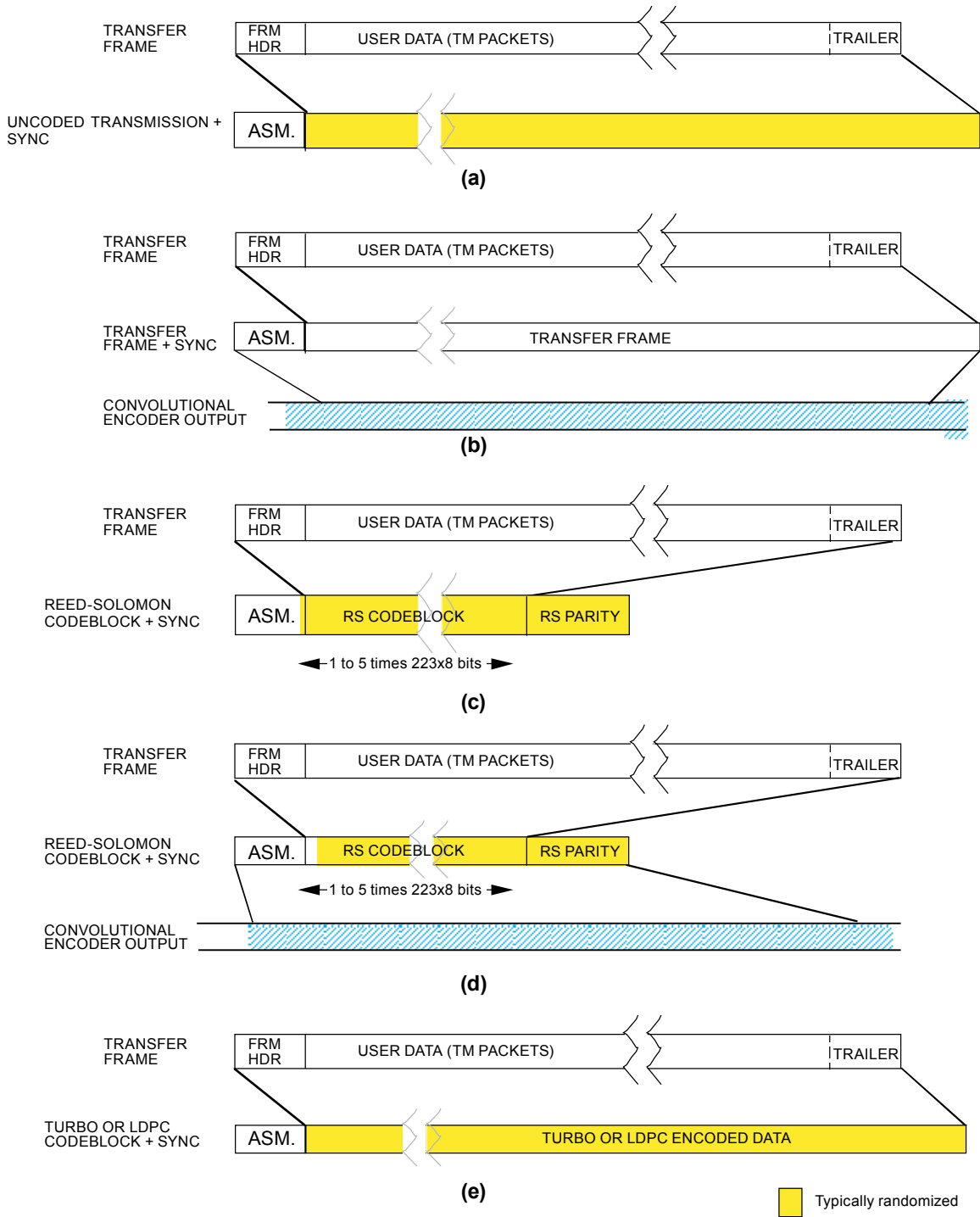

- (a) uncoded transmission
- (b) convolutional code only
- (c) RS code only
- (d) concatenated RS and convolutional
- (e) Turbo or LDPC code¹

Figure 2-2: Telemetry Data Structures

¹ Figure 8-1 in reference [3] provides a detailed view of transfer frames sliced to form LDPC codeblocks.

3 TM SYNCHRONIZATION AND CHANNEL CODING

3.1 INTRODUCTION

Channel coding² is a signal-processing technique by which data can be sent from a source to a destination through a noisy channel so that distinct messages are easily distinguishable from one another. This allows reconstruction of the data with improved reliability.

In spacecraft, the data source is usually digital, with the data represented as a string of ‘zeros’ and ‘ones’. A channel encoder (or simply ‘encoder’) is then a device that takes this string of binary data and produces a modulating waveform as output. If the channel code is chosen correctly for the particular channel in question, then a properly designed decoder will be able to reconstruct the original binary data even if the waveforms have been corrupted by channel noise. If the characteristics of the channel are well understood, and an appropriate coding scheme is chosen, then channel coding provides higher overall data throughput at the same overall quality (bit error rate) as uncoded transmission, but with less energy expended per information bit. Equivalently, channel coding allows a lower overall Bit Error Rate (BER) than the uncoded system using the same energy per information bit.

There are other benefits that may be expected from coding. First, the resulting ‘clean’ channel can benefit the transmission of compressed data. The purpose of data compression schemes is to map a large amount of data into a smaller number of bits. Adaptive compressors will continually send information to direct a ground decompressor how to treat the data that follows. An error in these bits could result in improper handling of subsequent data. Consequently, compressed data is generally far more sensitive to communication errors than uncompressed data. The combination of efficient low error rate channel coding and sophisticated adaptive data compression can result in significant improvement in overall performance (reference [6]).

Second, a low BER is also required when adaptive (or self-identified) telemetry is used. Adaptive telemetry is much like adaptive data compression in that information on how various ground processors should treat the transmitted data is included as part of the data. An error in these instructions could cause improper handling of subsequent data and the possible loss of much information.

Third, low error probability telemetry may allow a certain amount of unattended mission operations. This is principally because the operations systems will know that any anomalies detected in the downlink data are extremely likely to be real and not caused by channel errors. Thus operators may not be required to try to distinguish erroneous data from genuine spacecraft anomalies.

In a typical space channel, the principal signal degradations are due to the loss of signal energy with distance, and to the thermal noise in the receiving system. The codes described in reference [3] can usually provide good communication over this channel.

² This technique is called ‘channel’ coding because it is adapted to the statistical behavior of the channel and it applies to the overall transmitted data stream, not to specific sources only.

3.2 RECOMMENDED CODES

If interagency cross support requires one agency to decode the telemetry of another, then the codes recommended in reference [3] should be used. The recommended codes consist of: a constraint length 7, rate 1/2 convolutional code, and various punctured versions of it; (255,223) and (255,239) RS codes and arbitrary shortenings of them; codes formed by concatenating any of the recommended RS codes with any of the recommended convolutional codes; a series of Turbo codes of different rates and block sizes; and a series of LDPC codes of different rates and block sizes. A block diagram of the recommended coding system using concatenated codes appears in figure 3-1. A block diagram of the recommended coding system using Turbo or LDPC codes appears in figure 3-2.

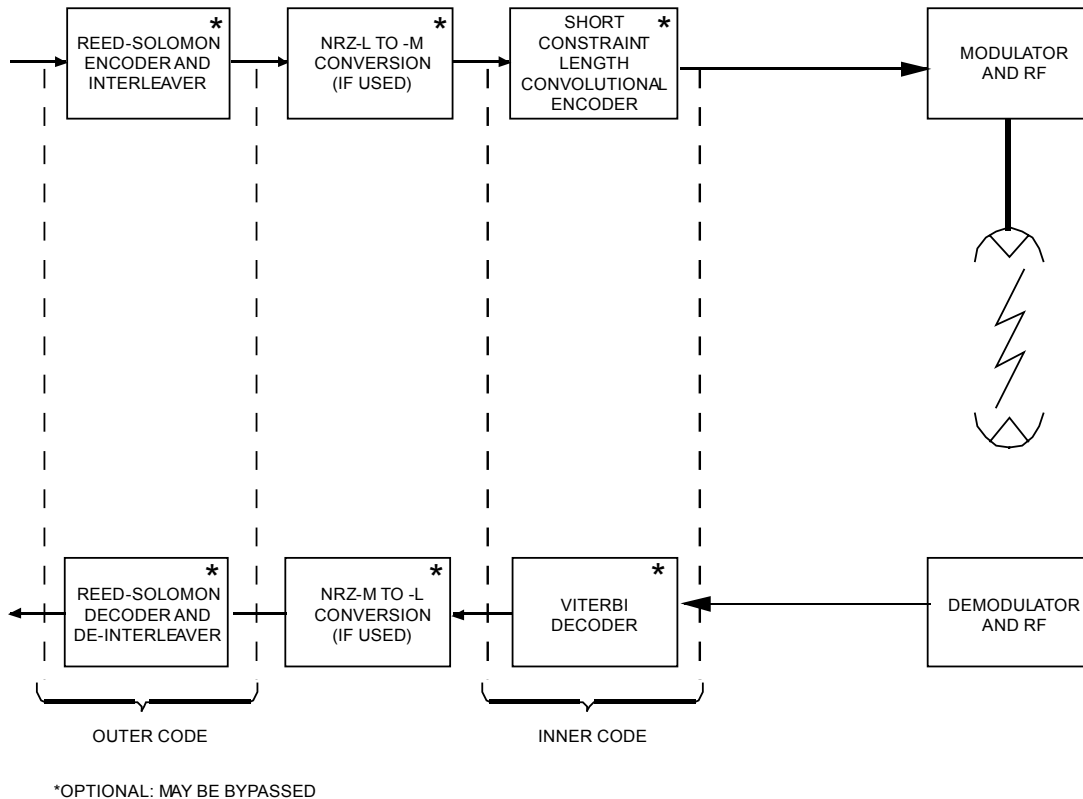

Figure 3-1: Coding System Block Diagram: Concatenated Codes

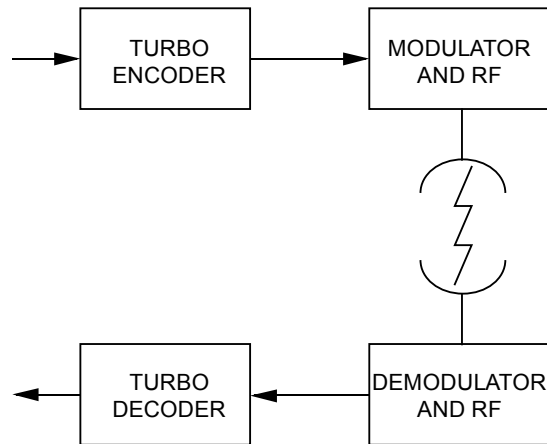

Figure 3-2: Coding System Block Diagram: Turbo Codes

These codes are included in the CCSDS Recommended Standard because they provide substantial coding gain over an uncoded system. They have already been incorporated, or are planned to be incorporated, into nearly all missions of member agencies of the CCSDS.

3.3 CHANNEL CODING PERFORMANCE

3.3.1 MEASURES OF PERFORMANCE

Performance of any channel code is measured by its error rate, relative to the amount of resources required to make the channel good enough to achieve that error rate. This Green Book shows the performance of the recommended codes on the Additive White Gaussian Noise (AWGN) channel, for which the relevant measure of required channel resources is given by a single parameter E_b/N_0 , the ratio of the received signal energy per information bit to the (one-sided) spectral density of the white Gaussian noise. This channel parameter E_b/N_0 is commonly called the bit signal-to-noise ratio, or bit-SNR.

The error rates achieved by the recommended codes are measured and reported in this Green Book in three different ways. The BER measures the error rate for individual bits; the Word Error Rate (WER) measures the error rate for individual codewords;³ and the Frame Error Rate (FER) measures the error rate for individual frames. These three error rates are well correlated with each other for any given code, but one error rate cannot generally be derived from another without an assumption of independence of errors. As an example, if a frame comprises L independent bits, then $FER = 1 - (1 - BER)^L$; this assumption is valid for uncoded frames on the AWGN channel, but not for frames subjected to any of the nontrivial recommended coding schemes.

³ There is a slight impreciseness in this definition of WER. The output of a decoder is generally an estimate of the information bits that were encoded, not an estimate of the actual encoded codeword. Such a decoder makes a ‘codeword error’ when at least one of its decoded information bits is incorrect. This interpretation is consistent with the term ‘codeword error’ because re-encoding the information sequence will produce the correct codeword if and only if the entire sequence of information bits is correct.

In some cases, some of these error rates are synonymous or uninformative. For example, $WER=BER$ for uncoded data because in this case each ‘codeword’ consists of one bit. Similarly, $FER=WER$ for CCSDS Turbo codes because in this case the CCSDS Transfer Frame consists of the information bits from one Turbo codeword. A codeword for unterminated convolutional codes is theoretically infinitely long, so $WER=1$ (except on an error-free channel) and thus WER is not a very interesting measure of performance in this case. It is natural to define WER for terminated convolutional codes. Even for unterminated convolutional codes, it is valid to compute FER on a segment (defining the frame) of the convolutional codeword.

3.3.2 FUNDAMENTAL LIMITS ON CODE PERFORMANCE

Good channel codes lower the error rate in the data, or, equivalently, they can achieve desired error rates more efficiently as a function of the bit-SNR E_b/N_0 on the channel. Shannon (see reference [8]) derived fundamental limits on the performance of all codes. There are code-rate-dependent channel capacity limits on the minimum E_b/N_0 required for reliable communication that are theoretically achievable by codes of a given rate in the limit of infinite block sizes. In addition, there are block-size-dependent limits that preclude capacity-attaining performance when the code’s block size is also constrained.

Code-Rate-Dependent Capacity Limits—Figure 3-3 shows the Shannon-limit performance curves for a binary-input AWGN channel for rates $r=1/6, 1/4, 1/3,$ and $1/2$. These curves show the lowest possible bit-energy-to-noise ratio E_b/N_0 required to achieve a given BER over the binary-input AWGN channel using codes of these rates.

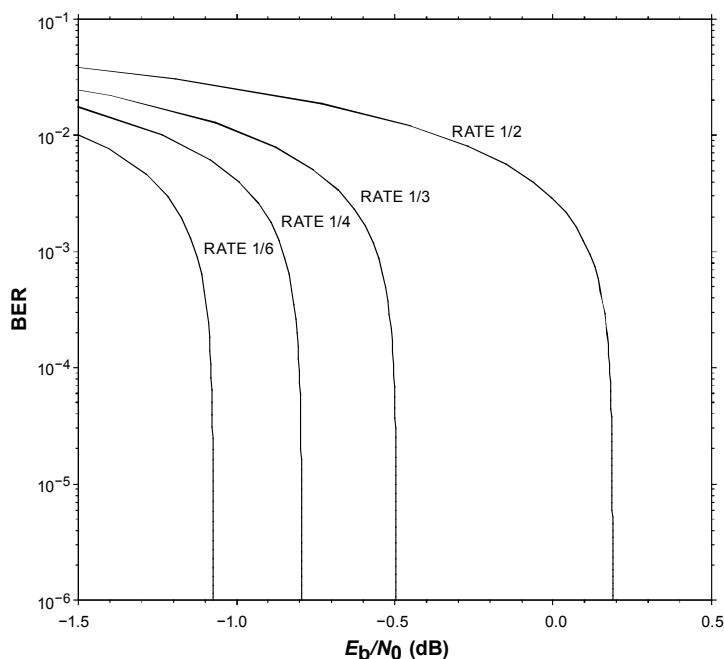

Figure 3-3: Capacity Limits on the BER Performance for Codes with Rates 1/2, 1/3, 1/4, and 1/6 Operating over a Binary Input AWGN Channel

For low BER, each of these capacity-limited performance curves approaches a vertical asymptote dependent on the code rate. The asymptotes are at 0.2 dB for rate 1/2, -0.5 dB for rate 1/3, -0.8 dB for rate 1/4, and -1.1 dB for rate 1/6. The vertical asymptote for the ultimate Shannon limit on performance (i.e., rate $\rightarrow 0$) is -1.6 dB. A comparison of these limits shows the improvement that is theoretically possible as a result of lowering the code rate. For example, for a binary-input AWGN channel, rate-1/2 codes suffer an inherent 0.7 dB disadvantage relative to rate-1/3 codes, a 1.0 dB disadvantage relative to rate-1/4 codes, and a 1.8 dB disadvantage relative to the ultimate limit (rate $\rightarrow 0$).

Codeword-Length-Dependent Limits on Code Performance — Just as a constraint on code rate raises the minimum threshold for reliable communication above the ultimate unconstrained capacity limit, so does a constraint on codeword length. The theoretical limits shown in figure 3-3 assume no constraint on block size. Approaching these limits requires that block sizes grow arbitrarily large.

Figure 3-4 shows some classic Shannon sphere packing lower bounds on the performance of arbitrary codes of a given block size and code rate on the AWGN channel with unconstrained input (i.e., not necessarily binary-input as in figure 3-3). The curves labeled ‘bound’ are the block-size-dependent bounds for each code rate. The horizontal asymptotes labeled ‘capacity’ are the rate-dependent capacity limits. These asymptotes are slightly different from the vertical asymptotes in figure 3-3 because they represent capacity limits for an unconstrained-input channel instead of a binary-input channel.

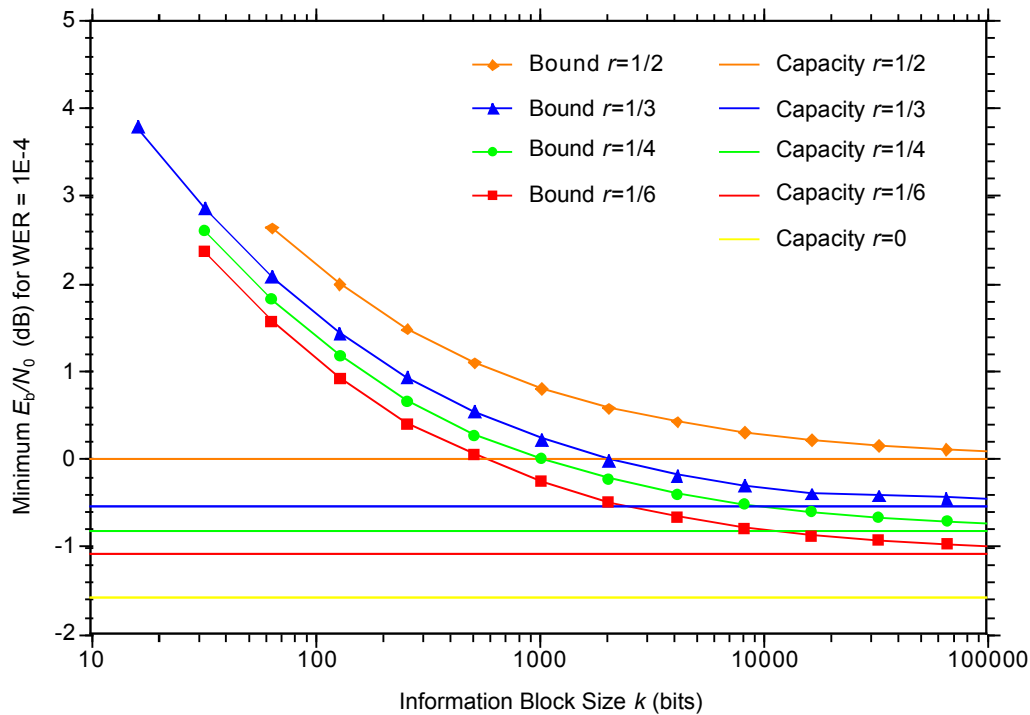

Figure 3-4: Shannon Sphere-Packing Lower Bounds on the WER Performance for Codes with Varying Information Block Length k and Rates 1/6, 1/4, 1/3, 1/2, Operating over an Unconstrained-Input AWGN Channel

This figure shows that, for any given code rate, the minimum threshold for reliable communication is significantly higher than the corresponding ultimate limit for that code rate, if the codeword length is constrained to a given finite size. For example, 1000-bit blocks have an inherent advantage of about 1.3 dB compared to 100-bit blocks for each of the four code rates plotted. An additional gain of just over 0.5 dB is potentially obtained by going from 1000-bit blocks to 10000-bit blocks, and another 0.2 dB by going to 100000-bit blocks. After that, there is less than another 0.1 dB of improvement available before the ultimate capacity limit for unlimited block sizes is reached.

3.3.3 EXAMPLES OF PERFORMANCE OF RECOMMENDED CODES

The relative performance of various recommended (non-punctured, non-shortened) codes on a Gaussian channel is shown in figure 3-5. Here, the input is constrained to be chosen from between two levels because biphasic modulation is assumed throughout the Recommended Standard.⁴ These performance data were obtained by software simulation and assume that there are no synchronization losses (see reference [10] for a discussion on the effect of receiver tracking losses). The channel symbol errors were assumed to be independent: this is a good assumption for the deep space channel, and an approximation for near-Earth links that ignores impulsive noise and Radio Frequency Interference (RFI). In this introductory comparison of code performance, ideal interleaving (i.e., symbol bursts are dispersed or randomly permuted to allow symbol errors to occur in a random manner; sometimes this is also referred to as ‘infinite interleaving’) is assumed in the concatenated code and BER only is used. Specific results with finite interleaving depth are given in 6.3; results for FER are given in later Sections discussing specific codes. It is clear from the figure that the convolutional code offers a coding gain of about 5.5 dB over an uncoded system at decoded BER of 10^{-5} . Concatenation of this code with the outer RS code results in an additional 2.0 dB of coding gain. Turbo codes can provide even higher coding gains, as illustrated in the figure for the Turbo code with rate 1/2 and block size 8920 bits. This code approaches within 1 dB the ultimate Shannon limit for codes with rate 1/2 and improves on the recommended concatenated code’s performance by about 1.5 dB.

These codes are included in the CCSDS Recommended Standard because they provide substantial coding gain over an uncoded system. They have already been incorporated, or are planned to be incorporated, into nearly all missions of member agencies of the CCSDS.

The next four sections describe the parameters and the performance of each recommended code in more detail, along with brief descriptions of their encoder and decoder realizations.

⁴ Biphasic modulation is appropriate for power-limited links, where bandwidth efficiency is not particularly important.

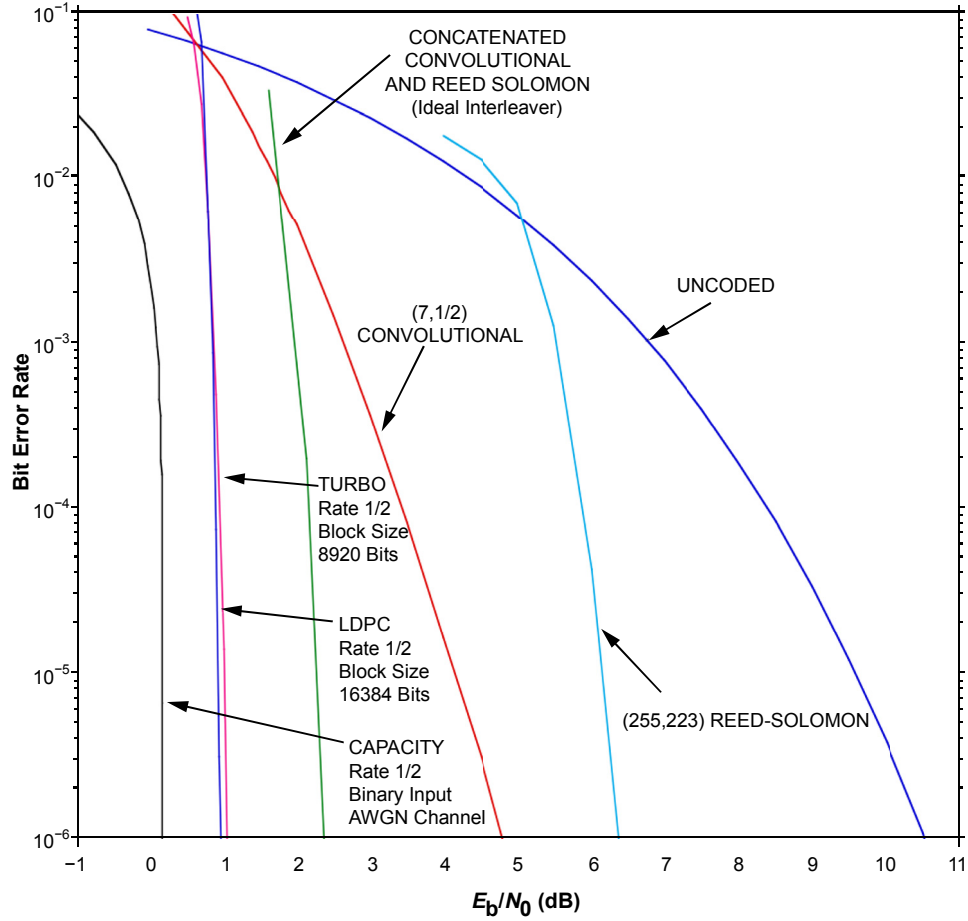

Figure 3-5: Performance Comparison of Selected Convolutional, Reed-Solomon, Concatenated, LDPC, and Turbo Codes

4 CONVOLUTIONAL CODES

4.1 INTRODUCTION

A rate $r=1/n$ convolutional encoder is a linear finite-state machine with one binary input, n outputs and an m -stage shift register, where m is the *memory* of the encoder. Such a finite-state encoder has 2^m possible states. The *constraint length* K of the convolutional code is defined as $K=m+1$, and the code is referred to as a $(K,1/n)$ code. In comparison to block codes, convolutional codes encode the input data bits continuously rather than in blocks.

In general, a rate $r=l/n$ convolutional encoder is a linear finite-state machine with l binary inputs and n binary outputs. A rate $r=l/n$ code can also be produced by puncturing a convolutional code of rate $r=1/n$.

4.2 ENCODER FOR THE (7,1/2) RECOMMENDED CODE

A (7,1/2) convolutional code selected for space applications in the 1970s was a standout performer for its time. Exhaustive search over all convolutional codes with $r=1/2$ and $K \leq 7$ found that only this code (not counting a few symmetric equivalents) was able to achieve a *free distance* $d_{\text{free}}=10$. By comparison, the best (6,1/2) code can only achieve $d_{\text{free}}=8$, and the best (8,1/2) code can only match the recommended (7,1/2) code's $d_{\text{free}}=10$. Maximizing the free distance was an important consideration because a convolutional code's BER with maximum likelihood decoding falls off exponentially with d_{free} at low error rates. It was also important to achieve a good d_{free} at a reasonably low value of constraint length K because every unit increase in K doubles the number of encoder states and therefore doubles the complexity of maximum likelihood decoding. Existing technology at the time this code was selected allowed maximum likelihood decoding of convolutional codes with constraint length $K=7$ but not much higher. Thus the recommended code was an obvious local optimum based on its d_{free} .

Convolutional codes with longer constraint lengths than $K=7$ were also used in the early days of space applications, but never standardized. Maximum likelihood decoding of these codes was infeasible; instead they were decoded by *sequential decoding* at a significant penalty in performance.

The recommended (7,1/2) code has another feature that makes it useful for space applications: it is *transparent*. Transparency means that at steady-state, if the input sequence to the encoder is inverted, the output will be inverted also. Similarly, if the input sequence to the decoder is inverted, at steady-state the output sequence of the decoder will be inverted too. This feature is useful because with Binary Phase Shift Keying (BPSK) modulation there is often a 180-degree phase ambiguity, and the demodulator can produce the inverse of the transmitted symbols even when it is in lock. With a transparent code, when the demodulator produces the inverse of the transmitted symbols, the decoder produces the inverse of the encoded bits. Since packetized telemetry includes various known headers, it is easy to recognize if the decoded bits have been inverted and to invert them back if necessary.

A diagram of an encoder for the recommended convolutional code of rate 1/2 and $K=7$ is shown in figure 4-1. The particular encoder structure depends on the manner in which the adders are connected to the shift register. These connections are denoted by a set of vectors:

$$\mathbf{g}_i = (g_{i,1}, g_{i,2}, \dots, g_{i,m}) \quad i = 1, 2, \dots, n, \tag{1}$$

where $g_{il} = 1$ denotes a connection between the i th stage of the shift register and the l th adder, and $g_{il} = 0$ denotes the absence of a connection. The complete set of the \mathbf{g}_i s defines the code.

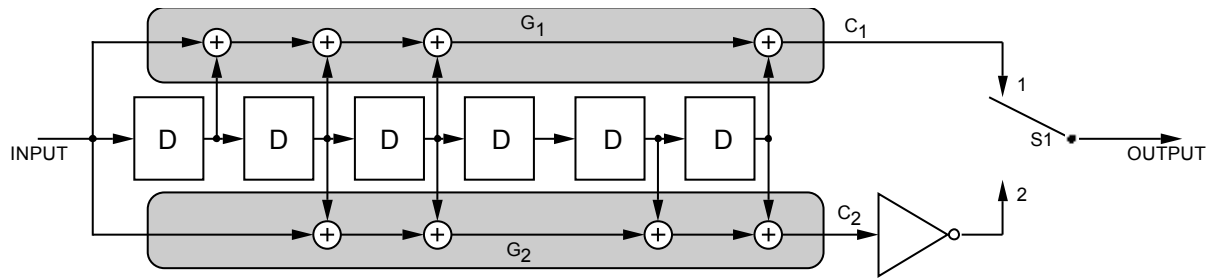

NOTES:



1.  = SINGLE BIT DELAY.
2. FOR EVERY INPUT BIT, TWO SYMBOLS ARE GENERATED BY COMPLETION OF A CYCLE FOR S1: POSITION 1, POSITION 2.
3. S1 IS IN THE POSITION SHOWN (1) FOR THE FIRST SYMBOL ASSOCIATED WITH AN INCOMING BIT.
4. \oplus = MODULO-2 ADDER.
5.  = INVERTER.

Figure 4-1: Example of Convolutional Encoder: Constraint Length $K=7$, Rate 1/2, CCSDS Standard Convolutional Code

The encoder for the CCSDS standard code is extremely simple, as shown in figure 4-1. It consists of a shift register and some exclusive OR gates that implement the two parity checks. The two checks are then multiplexed into one line. This means that the encoder can be made small and that it dissipates very little power. These are good attributes for spacecraft hardware.

It has been customary to invert one or the other parity check in the encoder. This operation makes the recommended code into a coset of a pure linear convolutional code. The inversion is performed to ensure that there are sufficient transitions in the channel stream for the symbol synchronizer to work in the case of a steady state (all ‘zeros’ or all ‘ones’) input to the encoder.⁵ Although alternate symbol inversion may increase or decrease the average transition density, depending on the data source model, it does limit the number of contiguous symbols without transition for a particular class of convolutional codes, independent of the data source model. Further, this limit is sufficiently small to guarantee acceptable symbol synchronizer performance for typical applications. The maximum number of contiguous symbols without transition for the convolutional code of figure 4-1 is 14.

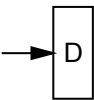
Historically, ESA, NASA-GSFC, and NASA-JPL have each used a different ordering of the two parity checks or has inverted a different parity check. Performance is not affected by these minor differences. But to reduce the number of options, CCSDS has adopted only one convolutional code for cross-support: all agencies are encouraged to adopt for all facilities the single convention described in reference [3].

A further convention issue may arise when the convolutional encoder output must be serial-to-parallel converted, for example, to modulate a QPSK signal. Figure 4-2 shows an example of this type of conversion. The rate-1/2 convolutional encoder output is formed by a sequence of pairs of bits, the second of which is inverted, according to figure 4-1. When this stream of bits is serial-to-parallel converted, the natural choice is that shown in figure 4-2: the sequence of c_1 bits is fed to the first channel (I channel), while that of \bar{c}_2 bits is fed to the second channel (Q channel). However, in some implementations, the two output channels could be swapped.

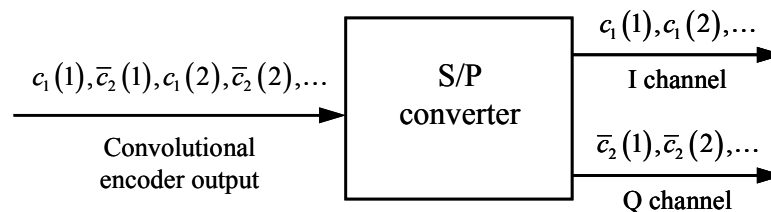

Figure 4-2: Example of Serial-to-Parallel Conversion of the Convolutional Encoder Output for QPSK Modulation

4.3 ENCODER FOR THE RECOMMENDED PUNCTURED CONVOLUTIONAL CODES

The CCSDS standard convolutional code, with constraint length $K=7$, has rate 1/2. The code rate can be increased by using a puncturing pattern, thus achieving an increase in bandwidth efficiency. Puncturing removes some of the encoded symbols before transmission, leading to a higher code rate and a lower bandwidth expansion than the original code, but with reduced error correcting performance. A block diagram of the punctured encoder is shown in figure 4-3.

⁵ See further discussion in section 9.

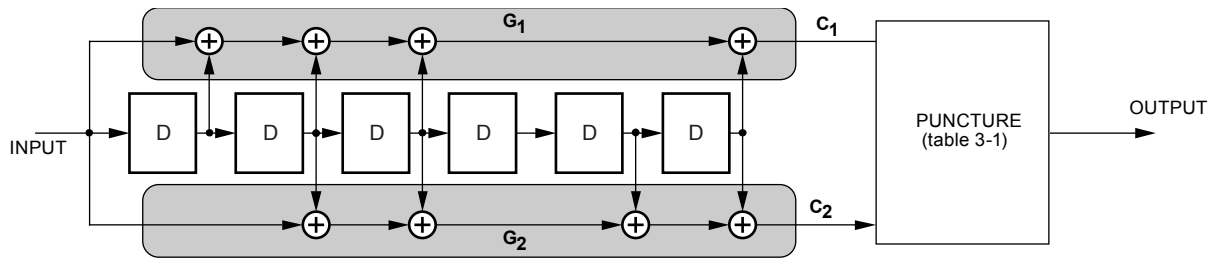

Figure 4-3: Encoder Block Diagram for the Punctured CCSDS Convolutional Codes

Starting from the CCSDS rate-1/2 convolutional code, the recommended punctured codes are obtained with fixed puncturing patterns yielding code rates 2/3, 3/4, 5/6, and 7/8, as reported in table 4-1.

Table 4-1: Puncturing Patterns for the CCSDS Punctured Convolutional Code Rates

Puncturing Pattern 1 = transmitted symbol 0 = non-transmitted symbol	Code Rate	Output $C_1(t), C_2(t)$ denote values at bit time t ($t=1,2,3,\dots$)
C_1 : 1 0 C_2 : 1 1	2/3	$C_1(1) C_2(1) C_2(2) \dots$
C_1 : 1 0 1 C_2 : 1 1 0	3/4	$C_1(1) C_2(1) C_2(2) C_1(3) \dots$
C_1 : 1 0 1 0 1 C_2 : 1 1 0 1 0	5/6	$C_1(1) C_2(1) C_2(2) C_1(3) C_2(4) C_1(5) \dots$
C_1 : 1 0 0 0 1 0 1 C_2 : 1 1 1 1 0 1 0	7/8	$C_1(1) C_2(1) C_2(2) C_2(3) C_2(4) C_1(5) C_2(6) C_1(7) \dots$

4.4 SOFT MAXIMUM LIKELIHOOD DECODING OF CONVOLUTIONAL CODES

Soft maximum likelihood decoding of convolutional codes can be accomplished by using the Viterbi algorithm (see references [21] and [25]), which will be illustrated for rate $1/n$ codes. The same decoding algorithm is applicable to both non-punctured and punctured codes, provided that the received symbol stream is ‘depunctured’ by inserting ‘zero’-symbols (i.e., neutral symbol values that do not favor either a received ‘0’ or ‘1’ bit, since ‘-1’ and ‘+1’ are used to represent ‘0’ and ‘1’ bits) at the positions where encoded symbols were removed during the encoding of the punctured code.

Before proceeding to the Viterbi algorithm, a discussion of the trellis representation of the convolutional encoder is desirable. For a constraint length K , code rate $r=1/n$, (K, r) convolutional encoder, the state is defined by the $(K-1)=m$ most recent bits in the shift register. Figure 4-4 shows an encoder for a $(3,1/2)$ convolutional code. (This is just an illustrative example, and is not the CCSDS recommended code.) The output bits and transitions between states can be recorded by the trellis diagram of figure 4-5.

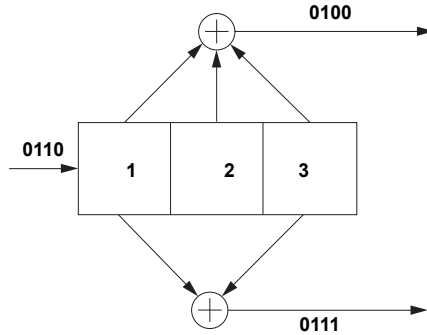

Figure 4-4: (3,1/2) Convolutional Encoder

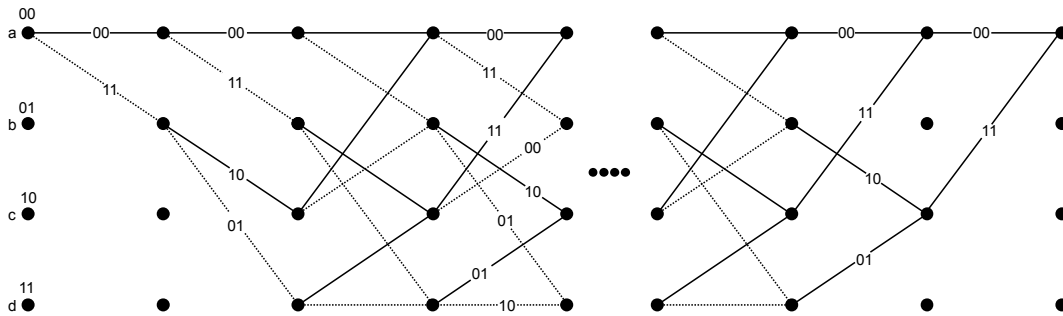

Figure 4-5: Trellis Representation of (3,1/2) Convolutional Code

The diagram starts in the all-‘zero’ state, node *a*, and makes transitions corresponding to the next data bit. These transitions are denoted by a solid line (branch) for a ‘0’ and by a dotted line for a ‘1’. Thus node *a* proceeds to node *a* or *b* with outputs bits ‘00’ or ‘11’. A branch weight is the number of ‘1’*s* in the *n* code symbols in the branch.

It has been shown (see reference [25]) that the Viterbi algorithm implements, in fact, maximum-likelihood decoding. An exhaustive search maximum-likelihood decoder would calculate the likelihood of the received data for code symbol sequences on all paths through the trellis. The path with the largest likelihood would then be selected, and the information bits corresponding to that path would form the decoder output. Unfortunately, the number of paths for an *L* bit information sequence is 2^L ; thus this exhaustive search decoding quickly becomes impractical as *L* increases.

With Viterbi decoding, it is possible to greatly reduce the effort required for maximum-likelihood decoding by taking advantage of the special structure of the code trellis. Referring to figure 4-5, it is clear that the trellis assumes a fixed periodic structure after trellis depth *K* is reached.

The paths are said to have diverged at some state, and some depth *j*, if at depth *j*+1, their information bits disagree. Later, paths can remerge after (*K*–1) consecutive identical information bits. The maximum-likelihood sequence estimation problem is formally identical to the problem of finding the shortest route through a certain graph. The Viterbi algorithm

then arises as a natural recursive solution. Considering a rate $1/n$ convolutional code, with $u_0 \dots u_{t-1}u_t u_{t+1} \dots$ denoting the information bits input to the encoder, at time t the encoder state is defined as

$$s_t = u_t \dots u_{t-K+1}. \quad (2)$$

Given a sequence of observations y_0, y_1, \dots, y_L , where $y_i = (y_{i1} \dots y_{in})$, every path may be assigned a ‘length’ proportional to metric $-\log p(y|s)$, where $p(y|s)$ is the likelihood function and $s = (s_0, \dots, s_L)$ is the state sequence associated with that path.

The Viterbi algorithm solves the problem of finding the state sequence for which $p(y|s)$ is maximum, or equivalently of finding the path whose length $-\log p(y|s)$ is minimum. It should be noted that to every possible state sequence s there corresponds a unique path through the trellis, and vice versa. If the channel is memoryless, then

$$-\log p(y|s) = \sum_{t=1}^L \lambda(s_t, s_{t-1}),$$

where

$$\lambda(s_t, s_{t-1}) = -\log p(y_t | s_t, s_{t-1}) = -\log p(y_t | s_t)$$

is the branch ‘length’ or metric. $T_t(s_t, s_{t-1})$ denotes the transition from state s_{t-1} to s_t associated with branch symbols $x_t = (x_{t1} \dots x_{tm})$, which correspond to the information sequence

$$u_t \dots u_{t-K}.$$

Therefore, the state transition can be defined as $T_t(s_t, s_{t-1}) = u_t \dots u_{t-K}$. $\mathbf{s}(s_t)$ denotes a segment (s_0, s_1, \dots, s_t) consisting of the states up to time t of the state sequence \mathbf{s} . In the trellis, $\mathbf{s}(s_t)$ corresponds to a path segment starting at the state s_0 and terminating at state s_t . For any particular time t and state s_t , there will in general be several such path segments, each with some length

$$\lambda(\mathbf{s}(s_t)) = \sum_{i=1}^t \lambda(s_i, s_{i-1}).$$

The shortest such path segment is called the *survivor*, corresponding to the state s_t , and is denoted $\hat{\mathbf{s}}(s_t)$. For any time $t > 0$, there are 2^m survivors in all, one for each s_t .

Thus at any time t , one need remember only the 2^m survivors $\hat{\mathbf{s}}(s_t)$ and their lengths $\Gamma(s_t) = \lambda(\hat{\mathbf{s}}(s_t))$. To get to time $t+1$, one need only extend all time t survivors by one time unit, compute the lengths of the extended path segments, and, for each state s_{t+1} , select the shortest extended path segment terminating in s_{t+1} as the corresponding time $t+1$ survivor. Recursion proceeds indefinitely without the number of survivors ever exceeding 2^m .

The great advantage of the Viterbi maximum-likelihood decoder is that the number of decoder operations performed in decoding L bits is only $L2^m$, which is linear in L . Of course, Viterbi decoding as a practical technique is limited to relatively short constraint-length codes because of the exponential dependence of decoder operations on K . Recent convolutional codes for deep space communications have used constraint lengths up to 15. Constraint lengths of 24, 32, and even 40 have been used in the past for sequential decoders that have suboptimal performance with respect to maximum-likelihood decoders.

4.5 PERFORMANCE OF THE RECOMMENDED (7,1/2) CONVOLUTIONAL CODE

Figure 4-6 shows the simulated BER performance of the CCSDS rate-1/2 convolutional code. Besides the ideal case of unquantized soft decision, the curves obtained by considering 3-bit and 8-bit quantization are shown. Two possible quantization strategies are considered, namely, Quantization Strategy 1 and Quantization Strategy 2. Details on these quantization strategies are given in annex C. Different quantization levels have been considered, from unquantized soft decision to hard decision (corresponding to 1-bit quantization). It is shown that, by using Quantization Strategy 1, 8-bit quantization provides nearly ideal performance (less than 0.2 dB penalty with respect to unquantized curves), while hard decision suffers a loss greater than 2 dB. The use of Quantization Strategy 2 allows reducing to 6 the number of quantization bits required to achieve nearly ideal performance.

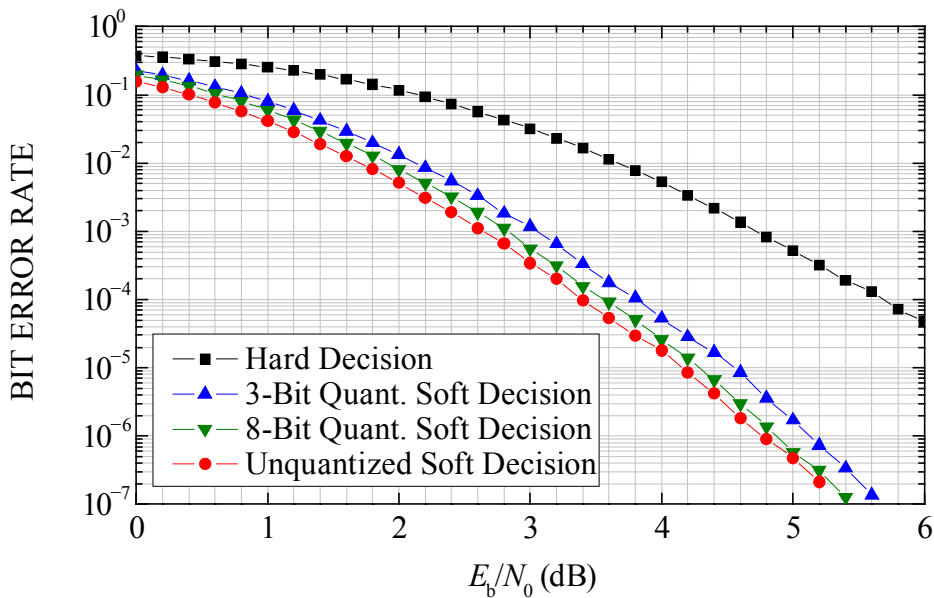

Figure 4-6: Bit Error Rate Performance of the CCSDS Rate-1/2 Convolutional Code with Quantization Strategy 1 and Different Quantizers

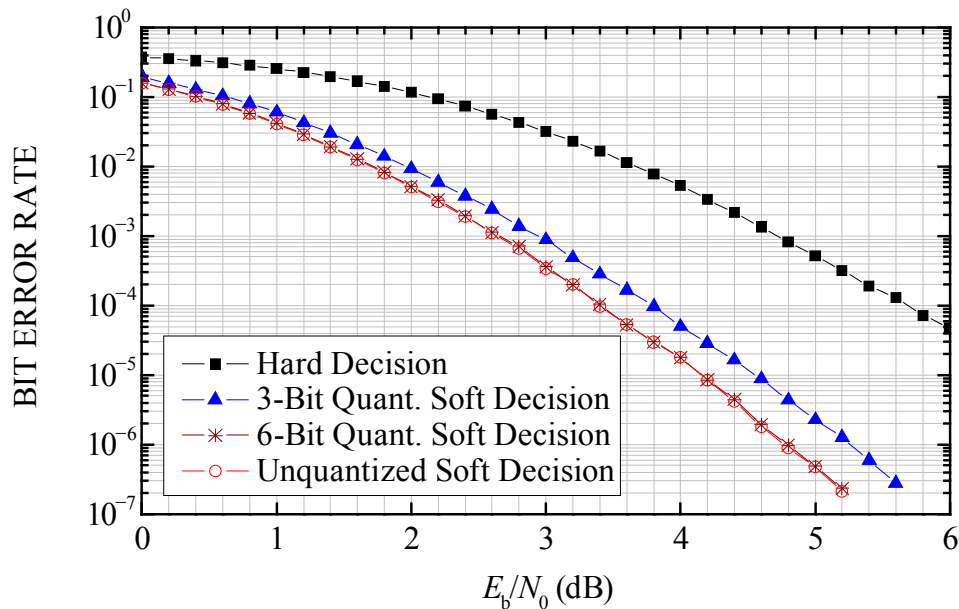

Figure 4-7: Bit Error Rate Performance of the CCSDS Rate-1/2 Convolutional Code with Quantization Strategy 2 and Different Quantizers

In principle, the Viterbi decoder should operate on the entire received sequence. This, however, would result in unacceptably long latency and excessive memory storage for the survivor sequences. In fact, since all survivor paths tend to merge into one single path when exploring the trellis at sufficient depth, practical implementations use a truncated Viterbi algorithm that forces the decision on the oldest symbol of the minimum metric path after a fixed and sufficiently long delay D . Actually, this quantity has the meaning of decoding delay, since it represents the number of bits that must be waited before each decoded bit becomes available at the output of the Viterbi decoder. It differs from the concept of decoding latency for block codes, which instead measures the time needed for completing reception of a codeword and performing decoding of the whole codeword. Just to avoid possible misunderstanding, it is better to denote this quantity by the term ‘truncation length’, which is also adopted in the literature. Computer simulations show that using a truncation length on the order of 5 times the constraint length (i.e., $D=5K$) is enough to obtain negligible degradations.

For the CCSDS rate-1/2 convolutional code, the dependence of the BER on the truncation length is shown in figure 4-8. Using a truncation length of only $D=30$ bits, that is, 5 times the memory m , the performance exhibits a very small degradation. Using $D=60$ bits nearly optimum performance is obtained. (All the curves have been obtained with unquantized soft decision.) For this reason, $D=60$ has been fixed in the following. The effect of further increasing the truncation length is discussed in 4.7.

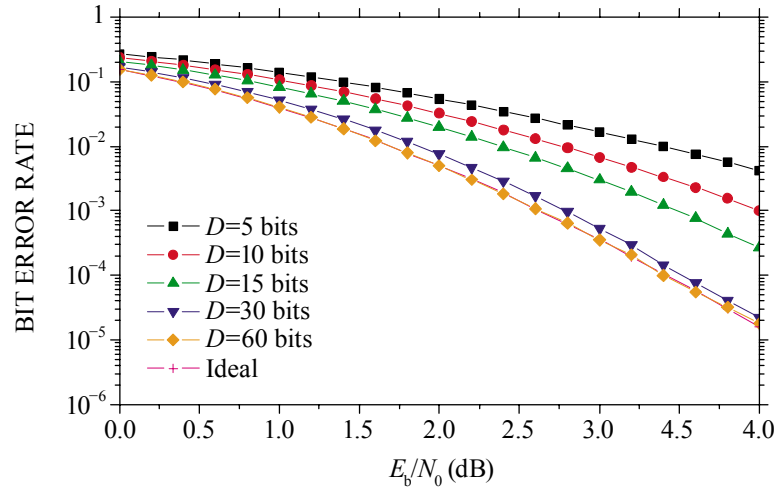

Figure 4-8: Bit Error Rate Performance of the CCSDS Rate-1/2 Convolutional Code with Different Truncation Lengths D

Telemetry data are collected in packets and transmitted in frames (see reference [2]). In principle, any frame length L up to 16384 bits could be acceptable. In figure 4-9 the FER at the output of the Viterbi decoder is reported for different frame lengths corresponding to those used for the concatenated (RS (255,223) + convolutional code) CCSDS code. A frame is in error if any of its constituent bits is in error. These curves have been obtained with unquantized soft decision and truncation length $D=60$ bits. Since the Viterbi decoder’s errors occur in bursts, the FER curves in figure 4-9 cannot be directly derived from the BER curve for $D=60$ bits in figure 4-8 by assuming independent bit errors.

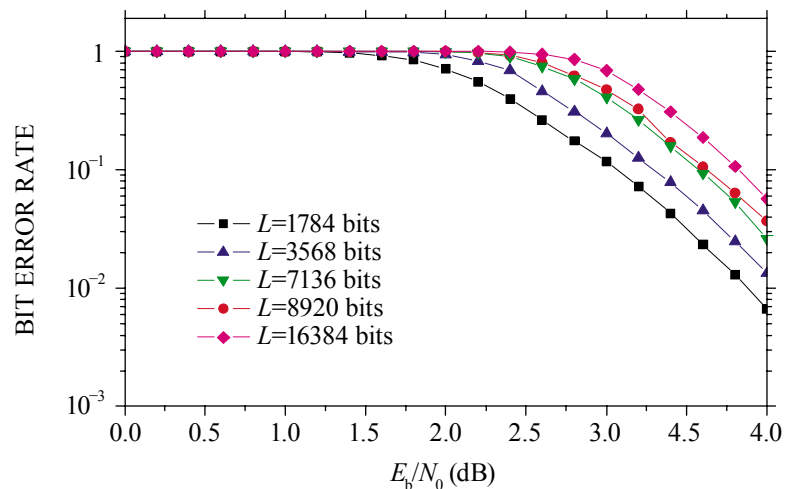
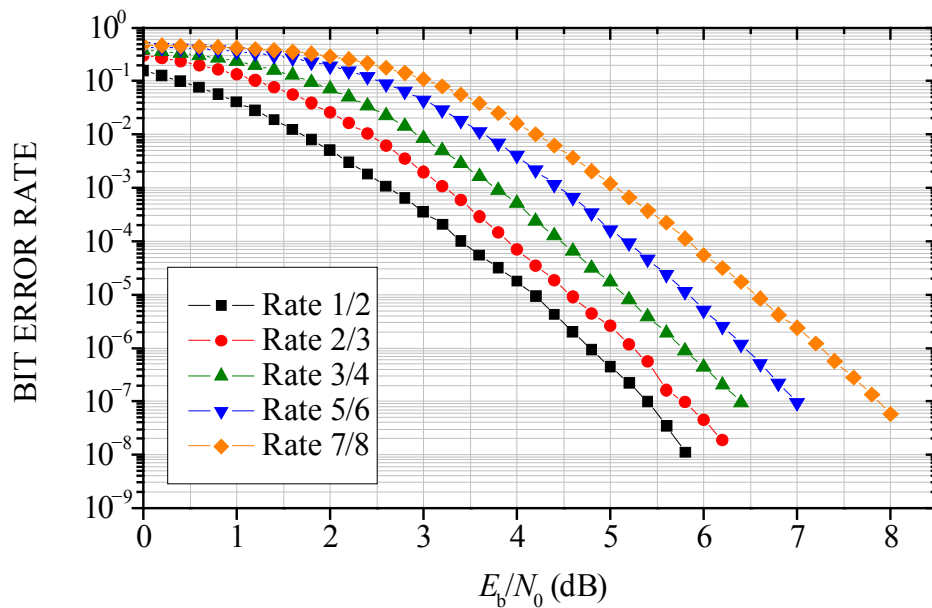

Figure 4-9: Frame Error Rate Performance of the CCSDS Rate-1/2 Convolutional Code with Different Frame Lengths and Truncation Length $D=60$

4.6 PERFORMANCE OF THE RECOMMENDED PUNCTURED CONVOLUTIONAL CODES

The BER performance of the CCSDS punctured convolutional codes is reported in figure 4-10. The curve relative to the non-punctured rate-1/2 CCSDS code is also reported for the sake of comparison. The expected performance degradation is confirmed (there is a gap of about 2.4 dB between the case of rate 1/2 and the case of rate 7/8), due to reduced bandwidth expansion. (All the curves have been obtained with unquantized soft decision and truncation length equal to 60 bits.)

The FER performance of the CCSDS punctured convolutional codes is reported in figure 4-11 for frame size 8920 bits.



NOTE – The performance of the original rate-1/2 code is reported for comparison.

Figure 4-10: Bit Error Rate Performance of the CCSDS Punctured Convolutional Codes

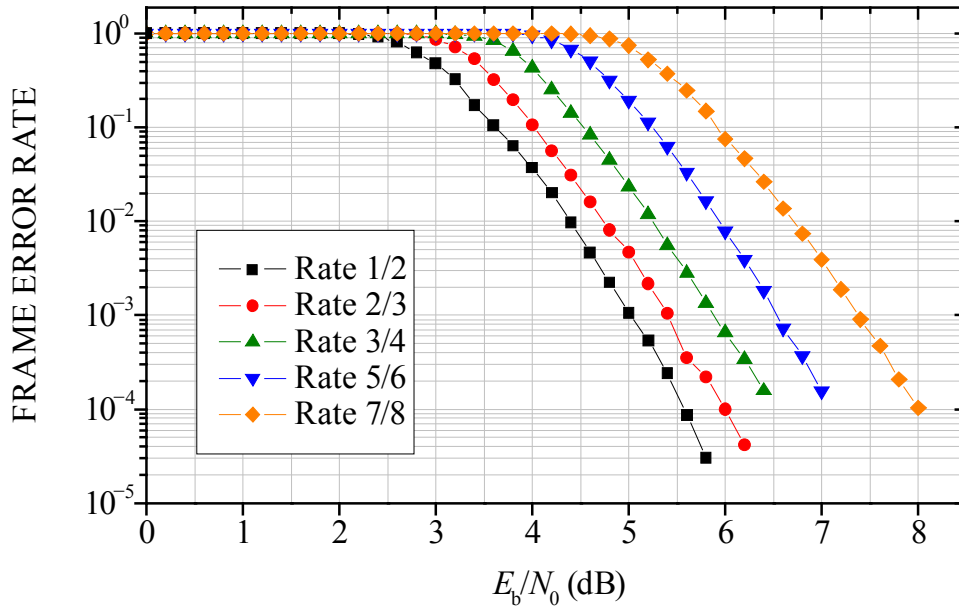

NOTE – The performance of the original rate-1/2 code is reported for comparison.

Figure 4-11: Frame Error Rate Performance of the CCSDS Punctured Convolutional Codes with Frame Length $L=8920$

4.7 EFFECT OF THE TRUNCATION LENGTH ON PERFORMANCE

As stated in 4.5, using a truncation length on the order of 5 times the constraint length (i.e., $D=5K$) is often enough to obtain negligible degradations with respect to the ideal behavior.

This rule does not take into account the code rate, while it has been verified that, for high rate codes, choosing $D=5K$ may produce some performance degradation with respect to the ideal behavior. An alternative heuristic criterion that takes into account this aspect is to set the truncation length equal to 2 to 3 times $K/(1-R)$, where K is the code constraint length and R is the code rate (reference [70]).

For the recommended punctured convolutional codes, the code rates $R=5/6$ and $R=7/8$ represent the two cases for which increasing the truncation length above $D=60$ produces the most significant effects. The simulated BER performance for these two cases is reported in figures 4-12 and 4-13.

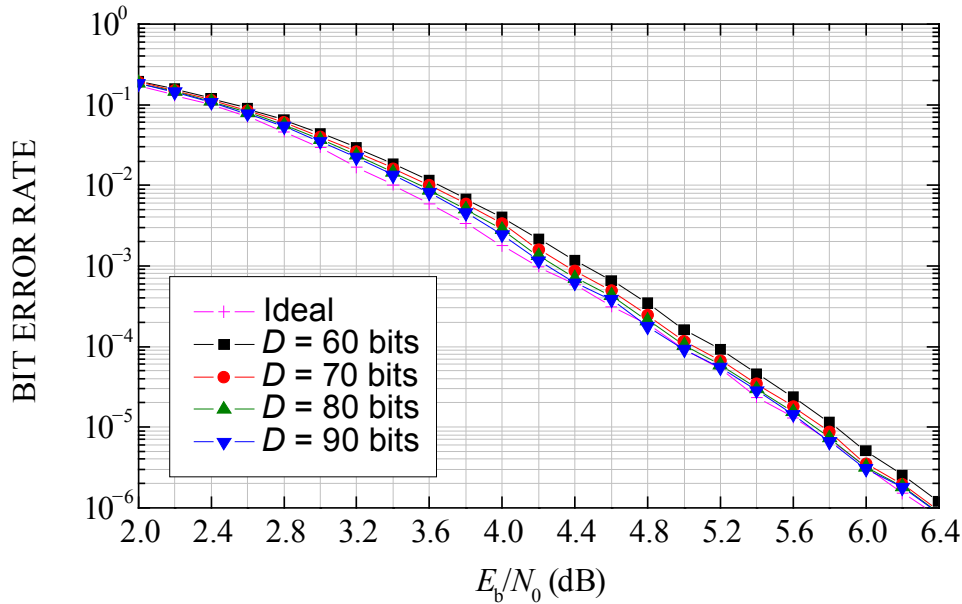

Figure 4-12: Bit Error Rate Performance of the CCSDS Rate-5/6 Punctured Convolutional Code with Different Truncation Lengths D

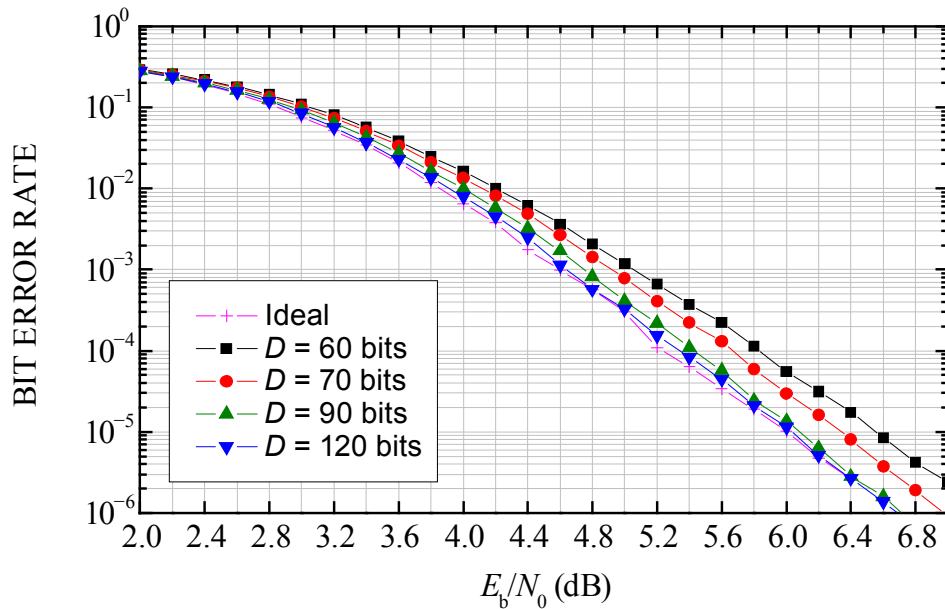

Figure 4-13: Bit Error Rate Performance of the CCSDS Rate-7/8 Punctured Convolutional Code with Different Truncation Lengths D

As observed in the simulations, for the case of the rate-5/6 punctured convolutional code, using the common truncation length ($D=60$) has a moderate effect ($0.1 \sim 0.2$ dB loss with respect to the ideal behavior). Increasing the truncation length up to $D=80$, that is, about $1.9 \cdot K/(1-R)$, makes the loss with respect to the ideal behavior negligible.

Concerning the rate-7/8 punctured convolutional code, it can be observed that using the common truncation length ($D=60$) produces a loss of about 0.5 ~ 0.6 dB with respect to the ideal behavior. Increasing the truncation length up to $D=90$, that is, about $1.6 \cdot K/(1-R)$, makes the loss with respect to the ideal behavior negligible.

So, it is confirmed that, at high code rates, using the common truncation length ($D=60$) produces a loss with respect to the ideal behavior of the Viterbi decoder. This loss can be practically eliminated by using a truncation length D set to $A \cdot K/(1-R)$, with A about (and even less than) 2.

5 REED-SOLOMON CODE

5.1 INTRODUCTION

RS codes (see reference [22]) are a particularly interesting and useful class of linear block codes. The block length n of an RS code is $q-1$, with $q=2^J$ being the alphabet size of the symbols. RS codes with k information symbols and block length n have a minimum distance $d=n-k+1$. These codes have been used effectively in a concatenated code scheme (see section 6), where the symbols in an ‘outer’ RS code are further encoded by an ‘inner’ convolutional code. The error probability is an exponentially decreasing function of the block length, and the decoding complexity is proportional to a small power of $n-k$. RS codes can be used directly on a channel with a small input alphabet by representing each letter in a codeword by a sequence of channel letters. Such a technique is useful on channels where the errors are clustered, since the decoder operation depends only on the number of sequences of channel outputs that contain errors.

Using symbols with $q=2^J$ for some J , the block length is $n=2^J-1$. For an arbitrarily chosen odd minimum distance d , the number of information symbols is $k=n-d+1$ and any combination of $E=(d-1)/2=(n-k)/2$ errors can be corrected. If one represents each letter in a codeword by J binary digits, then one can obtain a binary code with kJ information bits and block length nJ bits. Any noise sequence that alters at most E of these n binary J -tuples can be corrected, and thus the code can correct all bursts of length $J(E-1)+1$ or less, and many combinations of multiple shorter bursts. Therefore RS codes are very appropriate on burst-noisy channels such as a channel consisting of a convolutional encoder-AWGN channel-Viterbi decoder. RS codes are less appropriate for direct application to the AWGN channel where their performance is poorer than that of convolutional codes (see figure 3-5).

The RS code, like the convolutional code, is a transparent code. This means that if the channel symbols have been inverted somewhere along the line, the decoders will still operate. The result will be the complement of the original data (except, usually, for the codeword in which the inversion occurs). However, the RS code loses its transparency if virtual ‘zero’ fill is used. For this reason, it is mandatory that the sense of the data (i.e., true or complemented) be resolved before RS decoding, as specified in the Recommended Standard (reference [3]).

Two RS codes are recommended by CCSDS, both having codeword size $n=255$ symbols and symbol size $J=8$ bits or alphabet size $2^J=256$. The first code has information block size $k=223$, minimum distance $d=33$, and can correct $E=16$ errors. The second code has $k=239$, $d=17$, and can correct $E=8$ errors. The recommended RS codes are non-binary codes. Each member of the coding alphabet is one of 256 elements of a finite field rather than ‘zero’ or ‘one’. A string of eight bits is used to represent each element in the field so that the output of the encoder still looks like binary data.

An RS symbol size of eight bits was chosen because the decoders for larger symbol sizes would be less suitable for implementation with current technology, and because telemetry Transfer Frames are octet-based. This choice forces the longest codeword length to be 255

symbols. The recommended RS code with $E=16$ was chosen as this was shown to have the best performance when concatenated with the $(7, 1/2)$ convolutional inner code (see references [9] and [11]). Since two check symbols are required for each symbol error to be corrected, this results in a total of 32 check symbols and 223 information symbols per codeword. The RS code with $E=8$ was added later to the Recommended Standard (reference [3]) to allow another coding option with higher code rate.

The same encoding and decoding hardware can implement a shortened $(n', n'-2E)$ RS code, where $n' = 33, 34, \dots, 254$, as well as the non-shortened code with $n'=n=255$. This is accomplished by assuming that the remaining symbols are fixed: in the Recommended Standard (reference [3]), they are assumed to be all 'zero'. This virtual 'zero' fill allows the frame length to be tailored, if necessary, to suit a particular mission or situation. The shortened codes can correct the same number of errors (E) as the non-shortened code, but the overall code performance (energy efficiency per bit) generally (but not always) gets worse as the code rate is decreased due to shortening.

5.2 ENCODER

RS codes are block codes. This means that a fixed block of input data is processed into a fixed block of output data. In the case of the $(255, k)$ code, $k=255-2E$ RS input symbols (each eight bits long) are encoded into 255 output symbols. The RS code in the Recommended Standard (reference [3]) is systematic. This means that a portion of the codeword contains the input data in unaltered form. In the Recommended Standard (reference [3]), the first $k=223$ or 239 symbols are the input data for the two recommended codes, respectively.

A very simple block diagram of an (n, k) RS block encoder is shown in figure 5-1, where $n=2^J-1$ and $k=n-2E$. An RS symbol consists of a sequence of J bits so that there are 2^J possible RS symbols. All coding and decoding operations involve RS symbols, not individual bits. The input of the encoder consists of a block of $k=2^J-1-2E$ information symbols (or kJ information bits) from some data source. The result of the encoding operations is a codeword of length $n=2^J-1$ symbols, of which the first k are the same symbols as those entering to the left. This makes the code *systematic*. The remainder of the codeword is filled in with $2E$ *parity symbols*, where E is the number of correctable RS symbol errors in an RS codeword. An RS symbol is in error if one or more of the J bits making up the symbol are in error.

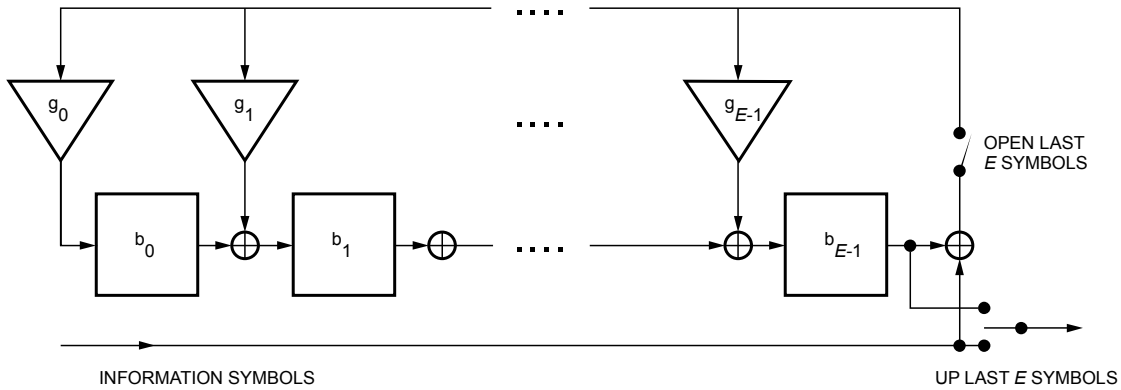

Figure 5-1: Block Diagram of an (n,k) Reed-Solomon Encoder

Attention is called to the specific recommended RS code with $J=8$, $E=16$, that is, the $(255,223)$ code. The basic codeword structure of this specific code with $J=8$, $E=16$, is given in figure 5-2. If desired, a ‘quick look’ at the data (information bits) would still be possible since the code is systematic. It should be noted that the overhead associated with the parity symbols is only around 15 percent. This percentage increases if the code is shortened.

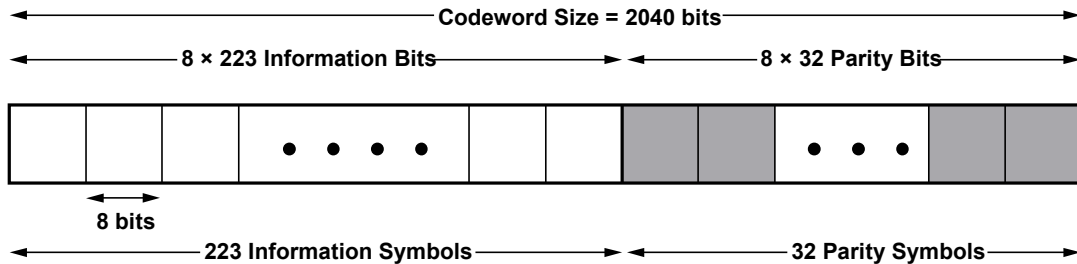

Figure 5-2: RS Codeword Structure, $J=8$, $E=16$

There are two polynomials that define each of the recommended RS codes in 4.2 (4) and (5) of reference [3] (also see reference [16]): a code generator polynomial over $GF(2^8)$ and a field generator polynomial over $GF(2)$. The field generator polynomial $F(x) = x^8 + x^7 + x^2 + x + 1$ is the same for both codes. The code generator polynomial $g(x)$ has degree $2E=32$ for the $(255,223)$ code and degree $2E=16$ for the $(255,239)$ code. The particular polynomials that define the recommended codes were chosen to minimize the encoder hardware. The code generator polynomials are palindromes (self-reciprocal polynomials) so that only half as many multipliers are required in the encoder circuits. The particular primitive element ‘ α ’ (and hence the field generator polynomial) was chosen to make these multipliers as simple as possible. An encoder using the ‘dual basis’ representation requires for implementation only a small number of integrated circuits or a single VLSI chip.

Figure 5-3 illustrates the construction of shortened RS codewords using virtual fill.

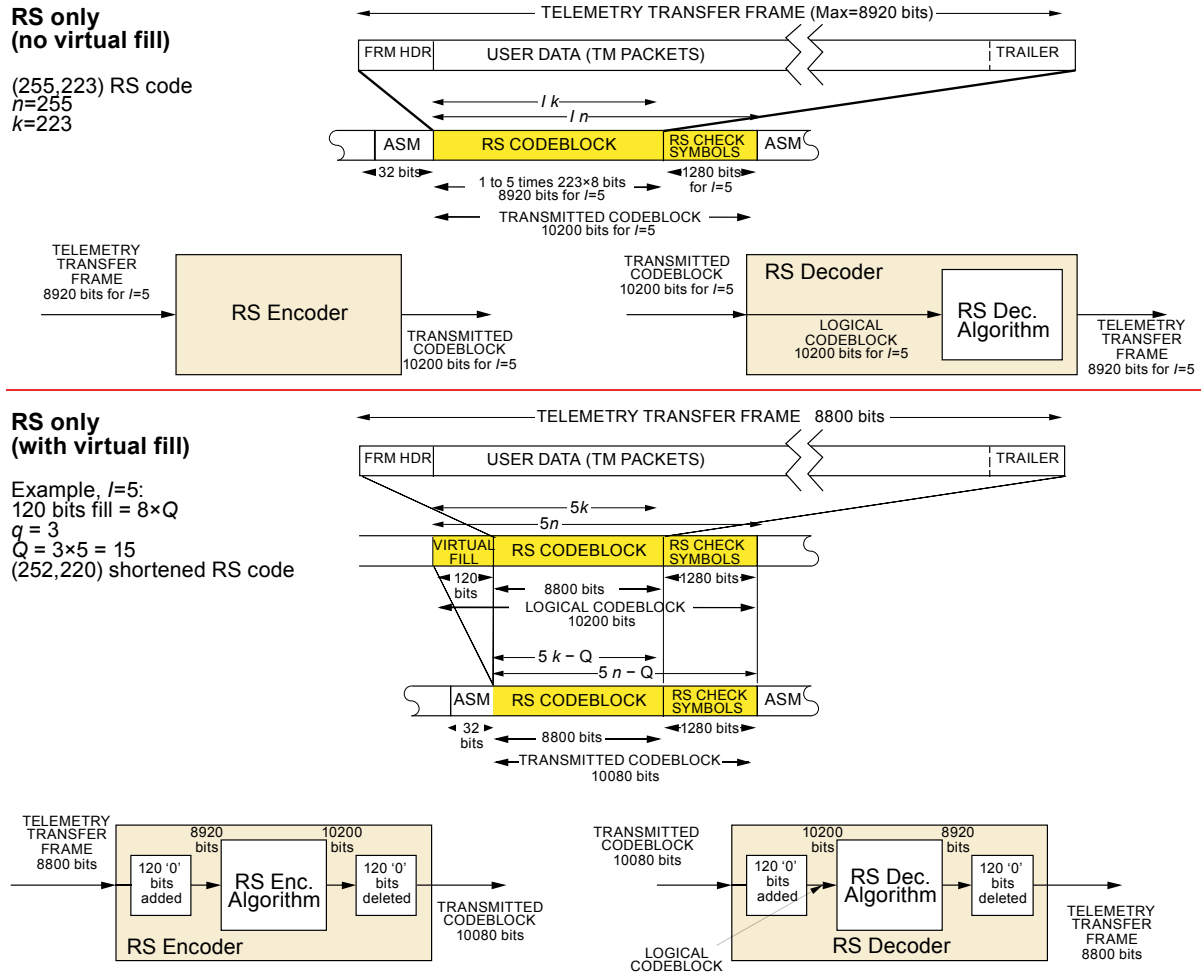

Figure 5-3: Illustration of RS Codeword Structure, with and without Virtual Fill

5.3 INTERLEAVING OF THE REED-SOLOMON SYMBOLS

When concatenated coding is used, or when the RS code is used without concatenation on a bursty channel, interleaving of the RS code symbols improves code performance. Without interleaving, burst error events would tend to occur within one RS codeword, and one codeword would have to correct all of these errors. Thus over a period of time there would be a tendency for some codewords to have ‘too many’ errors to correct (i.e., greater than E). The purpose of interleaving and de-interleaving is to make the RS symbol errors, at the input of the RS decoder, independent of each other and to distribute the RS symbol errors uniformly; in other words, to distribute the burst errors among several codewords. The performance of the RS decoder is severely degraded by highly correlated errors among several successive symbols.

Rectangular block interleaving of the RS symbols maximally spreads a burst of symbols with errors over a number of codewords equal to the ‘interleaving depth’ I . The interleaving depth is the number of RS codewords involved in a single interleaving and de-interleaving operation. Interleaving and de-interleaving operations over a channel can be described

simply by considering two $I \times n$ matrices, one at the input of the channel and one at the output (see figure 5-4). For interleaving, put the I codewords, each with length n , into rows 1,2,..., I of the matrix, then transmit the symbols of columns 1,2,..., n through the channel. For de-interleaving, do the reverse operation.

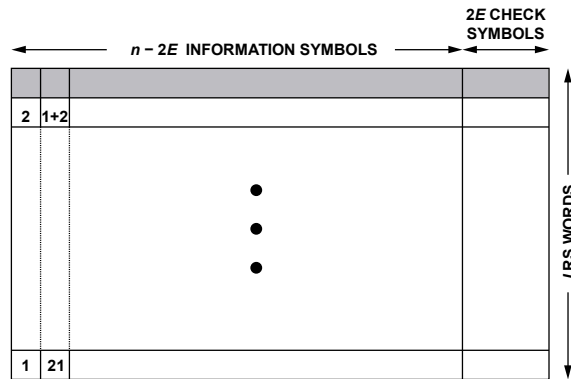

Figure 5-4: Matrix Used for Interleaving

Figure 5-4 illustrates the matrix used for interleaving I RS codewords (*interleaving depth I*). It should be noted that this matrix, by itself, does not specify in which order the input information symbols should fill up the matrix cells not reserved for parity. If successive information symbols are written into the matrix in the ‘natural’ ordering, *row by row*, so as to fill up codewords one at a time, this requires holding $I-1$ full codewords before any of the columns of the matrix can be read out. On the other hand, if successive information symbols are written into the matrix *column by column*, there is no need to store the entire array of code symbols because each column of I newly written symbols can be immediately read out as the next I symbols of the RS codeword, as soon as the encoder computes the (linear) contribution of each of these I symbols to its corresponding set of RS parity symbols. This is equivalent to the method specified in the Recommended Standard (reference [3]). One potential disadvantage of the recommended method is that it spreads individual RS codeword errors across more source blocks than the ‘natural’ ordering.

Interleaving of I RS codewords produces a codeblock of length $I * [\text{RS codeword length}]$; that is, the entire package of I RS codewords constitutes one RS codeblock. However, it is customary to compute WER for individual RS codewords rather than for the whole interleaved codeblock. The error rate on the interleaved codeblock is the FER for CCSDS frames.

5.4 HARD ALGEBRAIC DECODING OF REED-SOLOMON CODES

Unlike the ‘soft’ channel symbol values that are input to a Viterbi decoder for convolutional codes, the symbols input to the RS decoder are ‘hard’, which means that the RS decoder operates on symbols drawn from exactly the same alphabet as that used in producing the encoded symbols. This generation of hard symbol inputs to the RS decoder happens automatically when these symbols are generated by a Viterbi decoder for an inner convolutional code. In this case, the Viterbi decoder generates hard bit-by-bit decisions, and

eight consecutive bits from the Viterbi decoder are grouped to form one symbol from the 256-ary RS alphabet. When the RS code is used without an inner convolutional code, hard decisions should be made on each group of channel symbols corresponding to one RS octet.

It is possible to allow the decisions on channel symbols to possess a little bit of ‘softness’, in that an RS decoder may also accept ‘erasures’ in addition to hard symbols from its native alphabet. An erasure is appropriate whenever there is substantial decision uncertainty between two or more hard symbols because the RS code is capable of correcting twice as many erasures as errors. In the case of RS/convolutional concatenated coding, erasures are never produced by the standard Viterbi algorithm, but they may be generated by some modified versions of it.

The ‘errors-only’ RS decoder is somewhat simpler than the ‘errors-and-erasures’ version, but it is convenient to describe the more general case. The basic idea behind all RS decoding algorithms was developed by Berlekamp as described in reference [12], but there are dozens of variants of his basic algorithm in current use. A very detailed discussion on RS decoding algorithms can be found in reference [24].

Unlike the Viterbi decoder for convolutional codes, which always obtains a maximum likelihood decision for each bit, the RS decoder is an ‘incomplete, bounded distance’ decoder. The ‘errors-only’ decoder produces unflagged decoded output if and only if the sequence of corrupted symbols received differs from a valid codeword by no more than E symbols. For the ‘errors-and-erasures’ version, the corresponding condition is that $2t+e \leq 2E$, where e is the number of erased symbols and t is the number of discrepancies between non-erased received symbols and those of a valid codeword. For both types of decoders, there are error sequences that move the sequence of received symbols outside the ‘bounded-distance’ decoding radius around the true codeword, yet also leave it outside the bounded-distance decoding radius of all other codewords. In this case, the RS decoder is incomplete because it knows that the received sequence has been corrupted beyond its guaranteed correction capability, and it does not attempt to guess how to fix such corruptions. In fact, this type of ‘detectable’ corruption is much more likely to occur than an error sequence that moves the received symbol sequence inside the decoding radius of an incorrect codeword. For this reason, the RS decoder almost always knows when there are too many errors to correct a word. Whenever this happens, the decoder can flag the ‘detected’ error and inform the user of this fact.

5.5 PERFORMANCE OF THE RECOMMENDED REED-SOLOMON CODES

In decoding the RS codewords, essentially three events may happen.

- a) The first event (*correct decoding*) happens if there are E or fewer RS symbol errors in a codeword. In this case, the decoder successfully corrects the errors and outputs the correct information block.
- b) The second event (*detected error*) happens if the number of RS symbol errors in a codeword is more than E , but the corrupted codeword is not close to any other

codeword within the distance of E symbols. In this case, the RS decoder *fails to decode* and may (if desired) output the first k *undecoded* information symbols that in all likelihood contain some symbol errors.

- c) The third event (*undetected error*) happens if the number of RS symbol errors in a codeword is more than E , and the corrupted codeword is closer to some other codeword within the distance of E symbols. In this case, the decoder is fooled, decodes incorrectly, and outputs a wrong information block. In other words, it claims the decoded block as a correct one, and by doing this, it may create up to E additional symbol errors (compared to the number of errors in the uncoded information block).

Fortunately for most of the RS codes of interest with large alphabet size, in particular for the (255, 223) RS code, the probability that the third event happens is very small (see reference [23]). This probability has very little effect on the error probability performance of an RS code in the range of interest. In reference [23] it has been shown that the probability of the third event, that is, an incorrect decoding event, is less than $\frac{1}{E!}$. Therefore, for the practical range of interest in error probability performance, it almost surely can be assumed that only the first and second events happen. This conclusion is much less sure for the recommended (255,239) RS code with $E=8$.

If it can be assumed that symbol errors occur independently with probability V_s at the RS decoder input, then the probability P_w of undecodable word error at the output of the RS decoder is given by

$$P_w(n, E) = \sum_{j=E+1}^n \binom{n}{j} V_s^j (1-V_s)^{n-j}, \quad (3)$$

where $E = \frac{n-k}{2}$ is the number of correctable errors. This expression for P_w counts codeword errors for every occurrence of either the second or third event above.

The RS decoder output symbol error probability can be approximated by

$$P_s \approx V_s P_w(n-1, E-1) = V_s \sum_{i=E}^{n-1} \binom{n-1}{i} V_s^i (1-V_s)^{n-i-1}. \quad (4)$$

This approximate expression for P_s assumes that nearly all of the symbol errors come from the second event above, and in this case, it counts all of the erroneous symbols in the raw (undecoded) information portion of the RS codeword.

Finally, the bit error probability at the RS decoder output is given approximately by

$$P_b \approx \frac{V_b}{V_s} P_s,$$

where V_b is the bit error probability on the channel. On the AWGN channel, $V_s = 1 - (1 - V_b)^J$, and $V_b = Q(\sqrt{2E_s/N_0})$, where $Q(x) = \frac{1}{2} \operatorname{erfc}(x/\sqrt{2})$ is the unit Gaussian complementary cumulative distribution function, and E_s/N_0 is the channel symbol signal-to-noise ratio. This expression for P_b relies on the same assumptions as for P_s , and also on the assumption that the density of bit errors inside an erroneous undecodable J -bit RS symbol is the same as the density of bit errors inside any J -bit RS symbol regardless of whether the RS codeword is decodable or not and whether the particular RS symbol is erroneous or not.

The performance of the recommended RS codes with $E = 16$ and $E = 8$ is shown in figures 5-5 and 5-6, respectively, as a function of the channel symbol error probability V_s at the input of the decoder. This figure shows the bit, symbol, and word error probabilities, P_b , P_s , and P_w , respectively, at the output of the decoder, as computed from the formulas above.

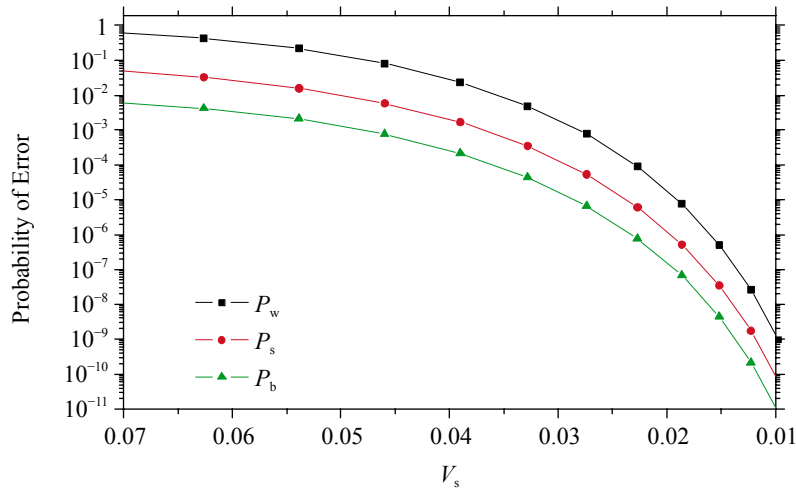

Figure 5-5: P_w , P_s , and P_b for the (255,223) RS Code with $E=16$

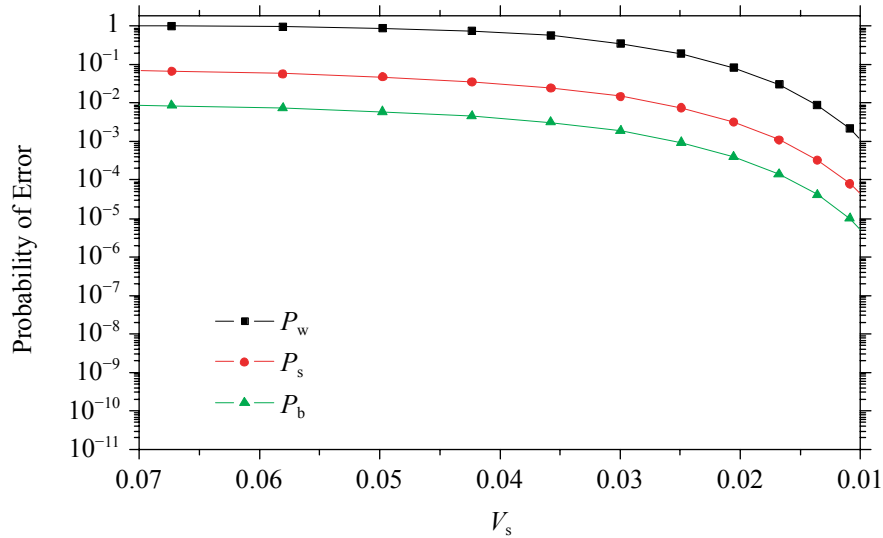

Figure 5-6: P_w , P_s , and P_b for the (255,239) RS Code with $E=8$

Figures 5-7 and 5-8 show BER and WER performance curves for the recommended RS codes as a function of the normalized bit signal-to-noise ratio E_b/N_0 on the AWGN channel. It may be noted that the WER curve for RS codes on the AWGN channel does not depend on the interleaving depth I , but for concatenated systems, WER does depend on I . The WER curves in figures 5-7 and 5-8 are the same as FER curves for interleaving depth $I=1$.

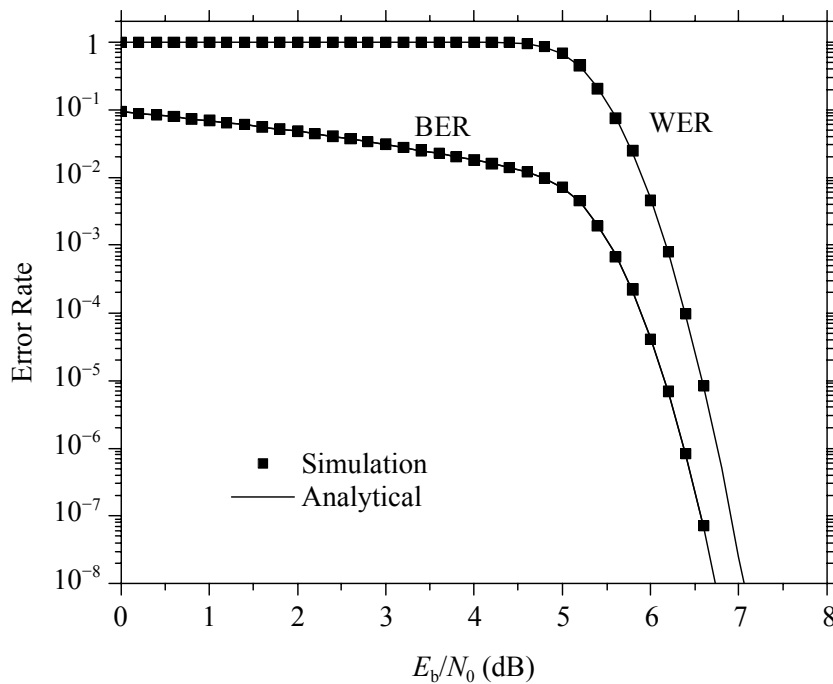

Figure 5-7: BER and WER Performance of the CCSDS $E=16$ Reed-Solomon Code (255,223): Simulated and Analytical Results for the AWGN Channel

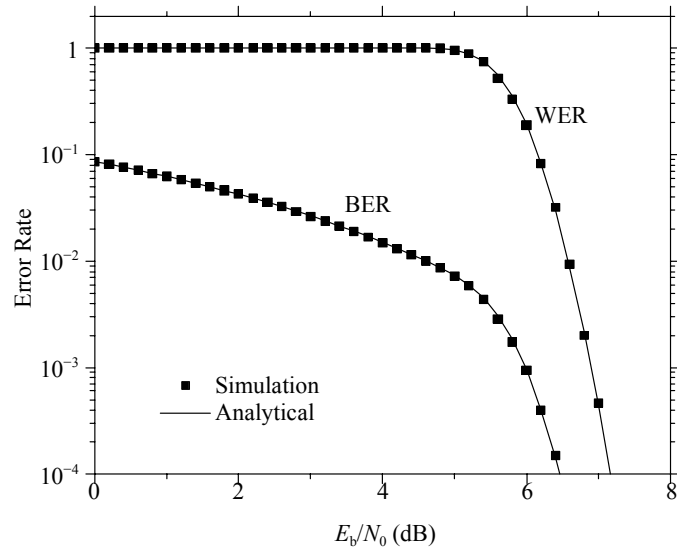

Figure 5-8: BER and WER Performance of the CCSDS $E=8$ Reed-Solomon Code (255,239): Simulated and Analytical Results for the AWGN Channel

Finally, figure 5-9 illustrates the effects of shortening the recommended $E=16$ and $E=8$ RS codes. On the AWGN channel, shortening may actually improve the performance (this is not the case for the recommended concatenated system). The best performance on the AWGN channel is achieved by a non-standard (255,173) RS code with $E=41$.

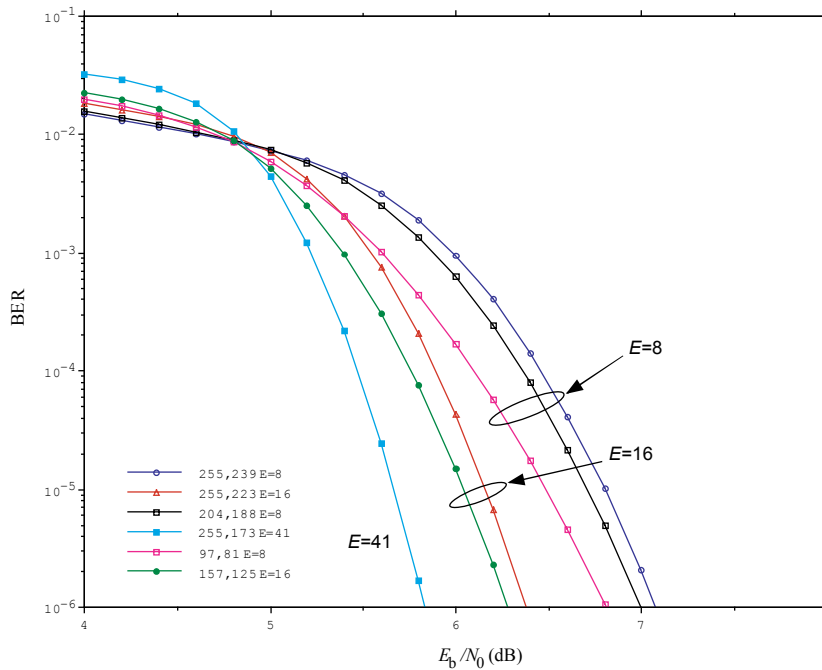

Figure 5-9: BER Performance Comparison of Shortened and Non-Shortened Reed-Solomon Codes on the AWGN Channel

6 CONCATENATED CODES: REED-SOLOMON AND CONVOLUTIONAL

6.1 INTRODUCTION

One method of building a strong code while maintaining manageable decoding complexity is to concatenate two codes: an ‘outer code’ and an ‘inner code’. This section discusses a particular concatenated coding scheme of importance to space communications (low SNR). The recommended concatenated coding system consists of an RS outer code and a convolutional inner code (which is Viterbi decoded). Typically, the inner convolutional code corrects enough errors so that a high-code-rate outer code can reduce the error probability to the desired level. The reader may wish to consult reference [26] for the theory of concatenated coding and references [9] and [27] for more information on the RS/Viterbi concatenated code.

The concatenated code in the Recommended Standard (reference [3]) uses either of the recommended RS codes (or shortened versions) together with any of the recommended convolutional codes (either of which may also be used separately under the Recommended Standard (reference [3])). A block diagram of this concatenated coding system is given in figure 6-1. The binary input data sequence is divided into 8-bit sequences to form symbols over a $2^8 = 256$ -ary alphabet. The RS code then encodes the symbols such that any combination of E or fewer symbol errors per RS word (255 symbols per word) can be corrected.

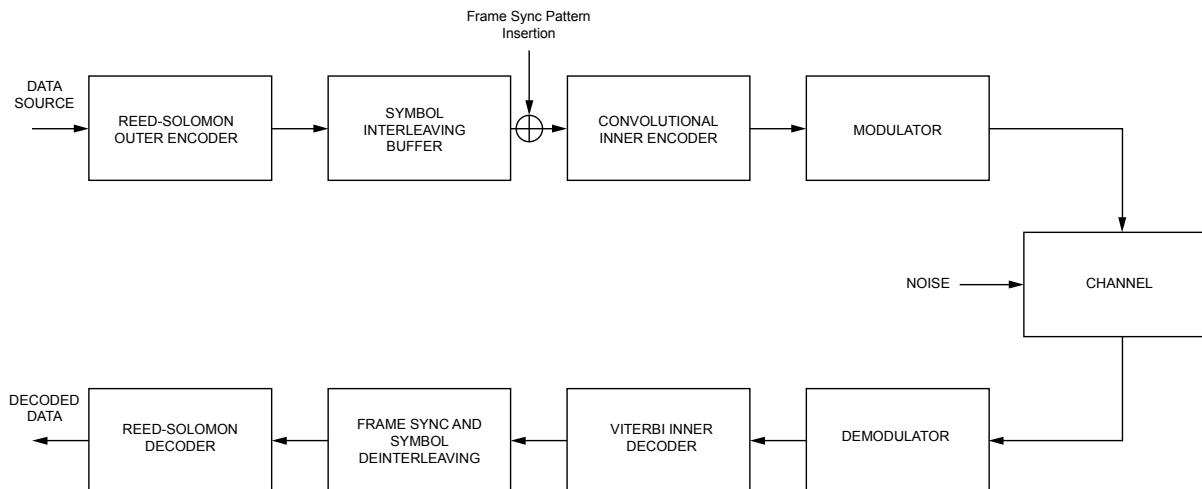

Figure 6-1: Concatenated Coding System Block Diagram

When quaternary modulation is used, CCSDS recommends encoding prior to the split to two channels. Figure 6-2 is an industry standard used by one of the CCSDS agencies for OQPSK, but is not compliant with the CCSDS Recommended Standard. It has the useful property that the four-phase state receiver ambiguities are automatically resolved. The convolutional code is transparent, so if it receives inverted symbols, it will output data inverted from the original. After the convolutional decode, the M-to-L conversion puts bits in the correct sense; then, because of the stagger (offset) the I and Q get merged in the correct order. Convolutional decoding is done properly and I/Q inversion and swap

ambiguity gets resolved without the need to resort to examining the ASM. With OQPSK, there is no need to resolve which is the I and which is the Q, since the time sequence of the bits puts them automatically in the right order, making it unnecessary to distinguish which is I and which is Q. In addition, the convolutional decoder hardware/firmware is rate-limited at some level. With the approach shown in figure 6-2, having separate convolutional encoders and decoders on the I and Q arms allows for higher data rates.

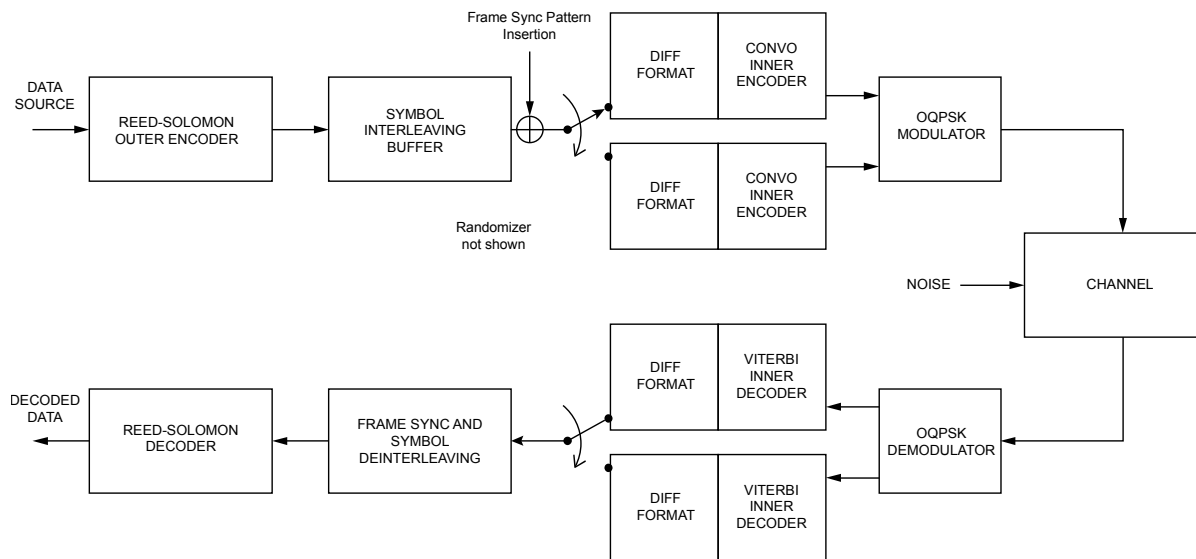

Figure 6-2: Concatenated Coding System Block Diagram, Not CCSDS Compliant

The reason that the recommended concatenated code operates as an effective teaming of its outer and inner codes stems from the nature of Viterbi decoding. The decoded bit errors made by the constraint-length-7 convolutional decoder tend to clump together in reasonably short bursts. In a concatenated coding system that uses a convolutional inner code, the outer code should be tailored to the burst error environment created by the convolutional decoder. A (255,255-2E) RS outer code is a good match for the convolutional inner code with constraint length 7 because the bursts of errors from the convolutional decoder typically have burst lengths ranging from a few bits to several constraint lengths. This corresponds to only a small number of 8-bit symbols in the outer code, and hence only a moderate amount of interleaving is required to prevent a few long bursts from exceeding the error correction capability of the RS decoder. On the other hand, it is advantageous for Viterbi decoder errors to be clustered within individual RS symbols because an RS symbol is equally wrong to the RS decoder whether it contains one bit error or eight bit errors. Because the Viterbi decoder errors occur in bursts comparable in length to the RS symbol size, 3 or 4 Viterbi decoder bit errors will typically be packed into a single RS symbol, and these cause much less damage than isolated bit errors to the error correction abilities of the outer code, at a given BER of the inner code. In summary, the typical error bursts from a constraint-length-7 convolutional decoder are long enough to take advantage of packing Viterbi-decoded bit errors into single 8-bit RS symbols, but not so long as to require an inordinate amount of interleaving to keep the RS code from being overwhelmed by overly lengthy error bursts.

6.2 ENCODING AND DECODING A CONCATENATED CODE

Encoding or decoding of a concatenated code is a simple matter of encoding or decoding the two codes in sequence.

Interleaving between the Outer and Inner Codes — When concatenated coding is used. A Viterbi decoder selects the most likely path through its trellis, based on the noisy received symbols. This path sometimes diverges from and re-merges with the correct path, resulting in a burst of bit errors. Simulations show that the decoder sometimes follows the wrong path for as long as several constraint lengths (see figure 6-3), and that a little over half the decoded bits are in error during those times. For the purpose of figure 6-3, the definition of error burst is those bits generated while the decoder has diverged from the correct path. It should be noted that this is not a general definition of error burst or burst length, but it is the definition used for figure 6-3. This definition is equivalent to saying that for a (K,r) convolutional code, a burst begins and ends with bit errors, and cannot contain $K-1$ or more consecutive correct bits. The motivation behind this form of the definition of a burst as used in figure 6-3 is that a string of $K-1$ consecutive correct bits will return the Viterbi decoder to the correct decoding path.

Without interleaving, Viterbi decoder burst error events would tend to occur within one RS codeword, so that one codeword would have to correct all of these errors. Thus there would be a tendency for some codewords to have ‘too many’ errors to correct (i.e., greater than E).

Note on Concatenated Codes: In the case of concatenated convolutional and RS codes, the encoding and decoding is done sequentially. It has been found that in some commercial decoder equipment used for near-Earth missions, because of the way the node synchronization threshold is set in the convolutional (Viterbi) decoder (see 9.3.2) for an output BER of 1×10^{-5} from that decoder, the Viterbi decoder cannot work, for a rate $\frac{1}{2}$ code, below an E_b/N_0 of about 4 dB. Hence the link designer must include an implementation loss factor in the link budget to account for this. The net effect is that the output of the RS decoder is almost error free.

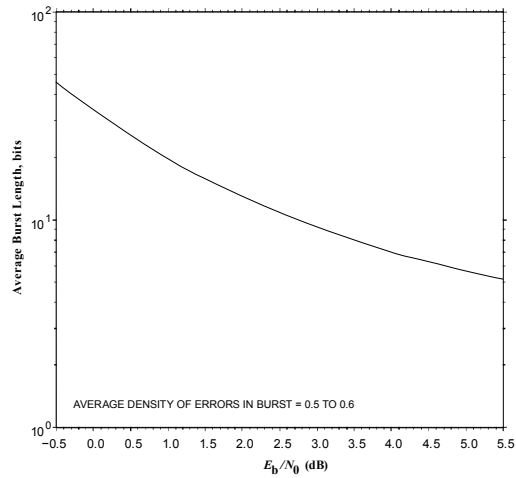

Figure 6-3: Average Burst Length vs. SNR, at the Viterbi Decoder Output, $K=7$ CCSDS Convolutional Code

Table 6-1 shows the frame lengths for all the recommended interleaving depths for the two (non-shortened) RS codes.

Table 6-1: Frame Lengths for All Interleaving Depths

Interleaver depth I	Frame length L , bits	
	$E=16$	$E=8$
1	1784	1912
2	3568	3824
3	5352	5736
4	7136	7648
5	8920	9560
8	14272	15296

6.3 PERFORMANCE OF THE RECOMMENDED CONCATENATED CODING SYSTEMS

Consider a concatenated coding system consisting of a (K,r) convolutional inner code of rate r and constraint length K , and an (n,k) RS outer code. It is assumed that the symbols are interleaved at a sufficient depth to ensure that symbol errors are independent at the RS decoder input. Then the bit, symbol, and word error probabilities, P_b , P_s , and P_w , respectively, are given by the formulas in the previous section, in terms of V_s , the symbol error probability at the input of the RS decoder or equivalently at the output of the Viterbi decoder, and V_b , the bit error probability at the output of the Viterbi decoder. The ratio V_b/V_s is estimated empirically and depends on the burst statistics of the inner decoder's error events at its typical operating SNR.

Figures 6-4 and 6-5 show the BER performance of the non-shortened (255,223) and shortened (255,239) RS codes with $E=16$ and $E=8$, respectively, concatenated with punctured and non-punctured convolutional codes, with ideal interleaving⁶ assuming that interleaving produces independent RS symbol errors. Performance curves for the non-concatenated convolutional codes and for the RS code alone are also shown for comparison. It should be noted that for bandwidth efficiency, it is better to use concatenations of RS and punctured convolutional codes than the RS code alone. Figure 6-6 shows the BER performance for both $E=16$ and $E=8$.

⁶ Actually the value $I=16$ has been used as the semi-analytical results are within 0.1 dB of fully simulated $I=16$ results.

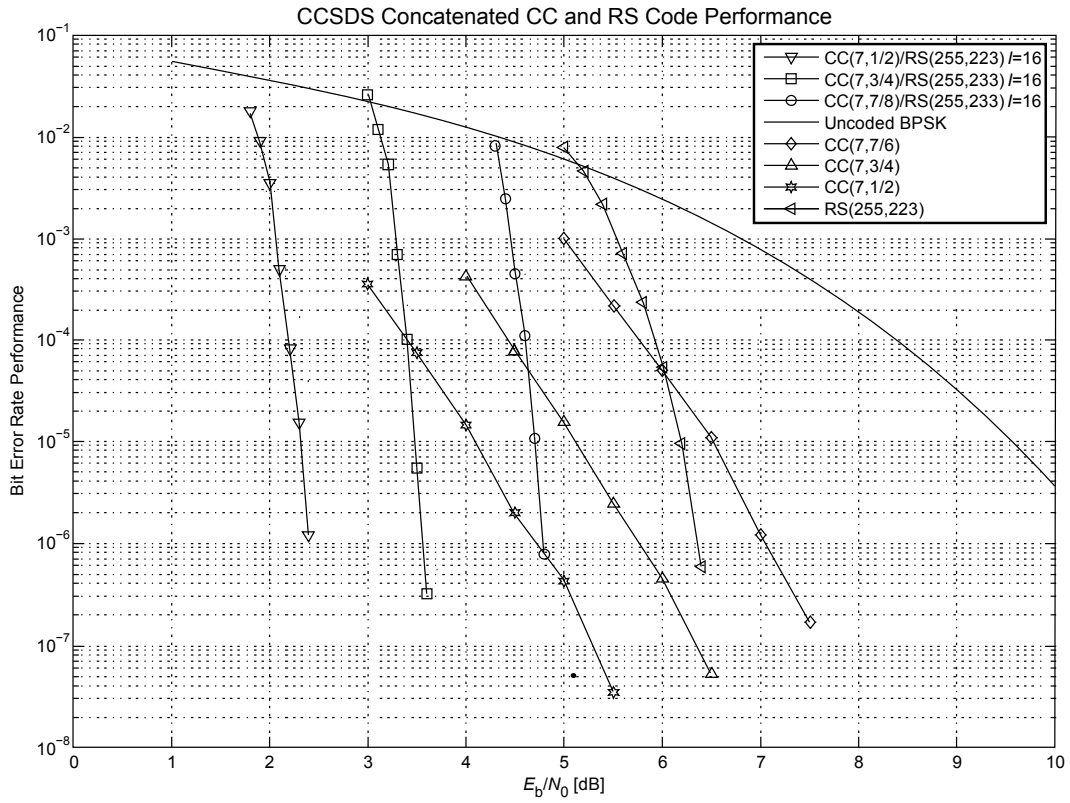

Figure 6-4: Performance of Concatenated Coding Systems with Ideal Interleaving, $E=16$, Punctured Codes

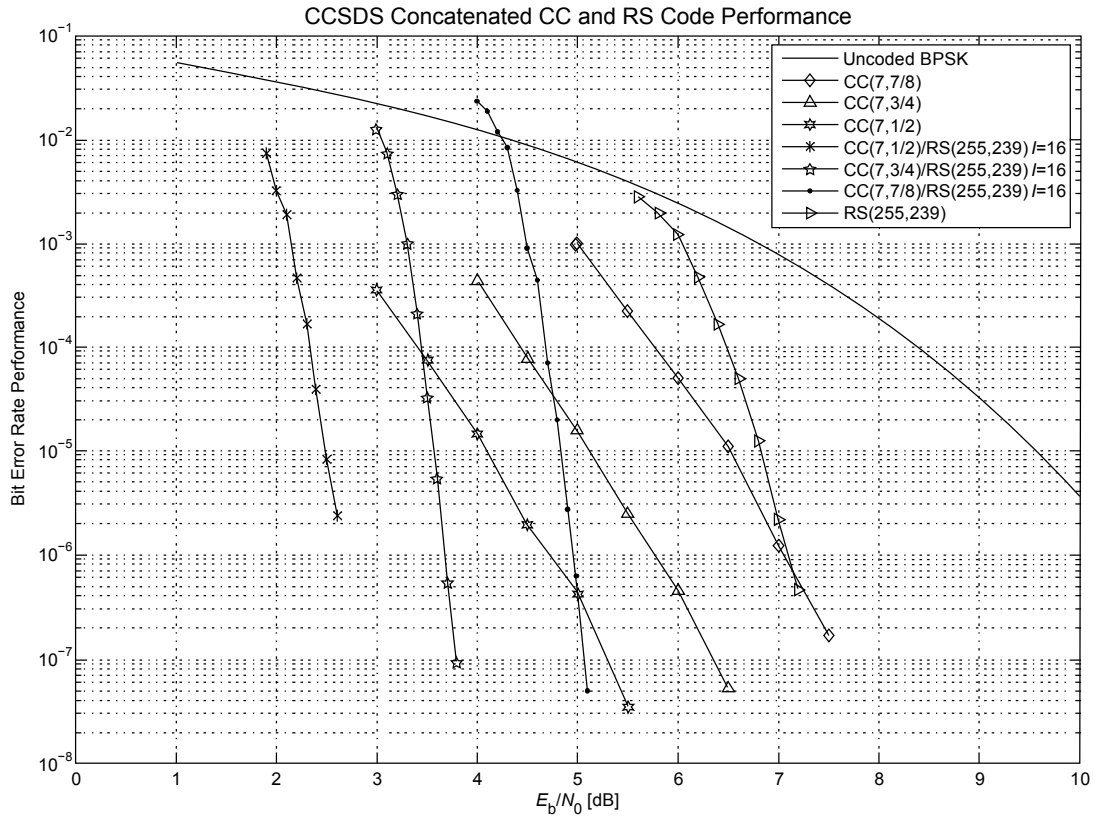

Figure 6-5: Performance of Concatenated Coding Systems with Ideal Interleaving, $E=8$, Punctured Codes

The convolutional decoder used to calculate the performance curves for all of the figures in this section operates with an unquantized maximum likelihood soft decision algorithm, corresponding to the ‘unquantized soft decision’ curve in figure 4-5. It should be noted that, in order to compare the performance of concatenated and non-concatenated codes, the E_b/N_0 values on the x -axis in all figures in this section refer to the information bit SNR.

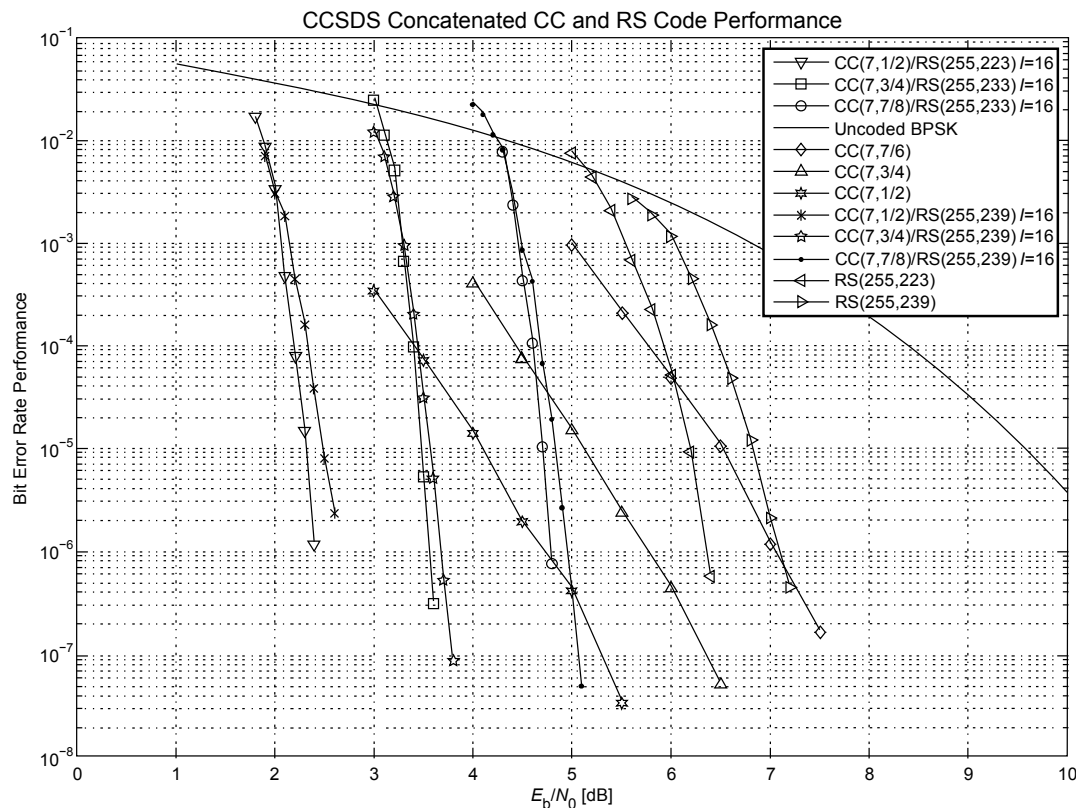

Figure 6-6: Performance of Concatenated Coding Systems with Ideal Interleaving, $E=16$ and $E=8$, Punctured Codes

Effects of Finite Interleaving — When the interleaving depth I is not large enough, the errors at the output of the Viterbi decoder cannot be considered as independent since this decoder tends to produce errors in bursts. The performance under finite interleaving must therefore take into account the statistics of these bursts either by devising a plausible model or by simulation. A possible model for burst lengths and arrival times was developed in reference [27] and is called the *geometric* model. This model provides an approximate estimate of the performance under finite interleaving but ignores the actual structure of the error patterns within the bursts. On the other hand, simulation is also problematic since very large amounts of Viterbi decoded data are necessary to provide reasonable confidence in the estimates of performance. A detailed description of methods used to obtain performance estimates is given in reference [28].

BER and WER results for finite interleaving are shown in figures 6-7 and 6-8, respectively, for the recommended concatenated system consisting of the non-shortened (255,223) RS code with $E=16$ and the non-punctured (7, 1/2) convolutional code, with different interleaving depths ranging from $I=1$ to $I=16$.

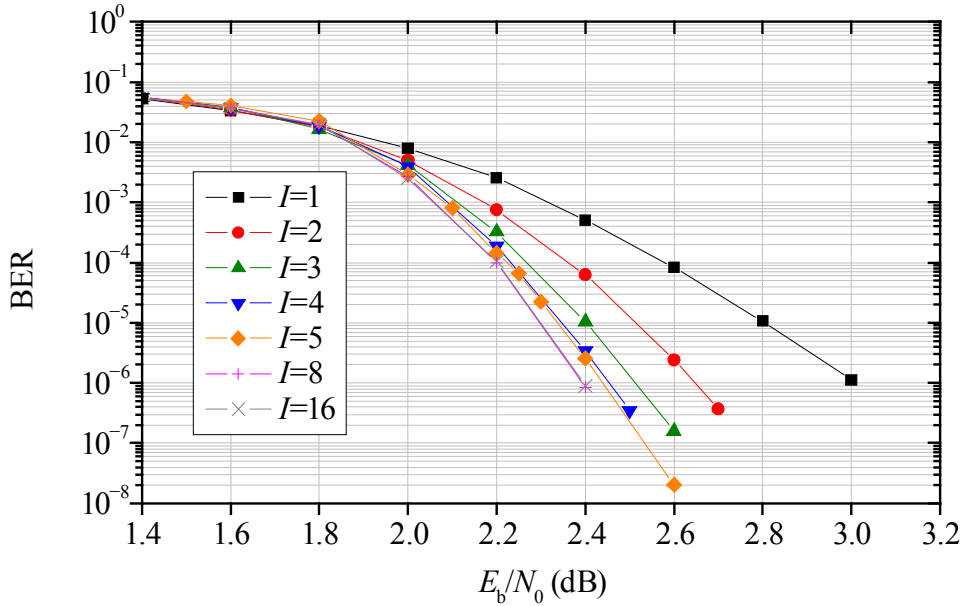

Figure 6-7: Bit Error Rate Simulated Performance of the CCSDS Concatenated Scheme with Outer $E=16$ Reed-Solomon Code (255,223) and Inner Rate-1/2 Convolutional Code as a Function of Interleaving Depth

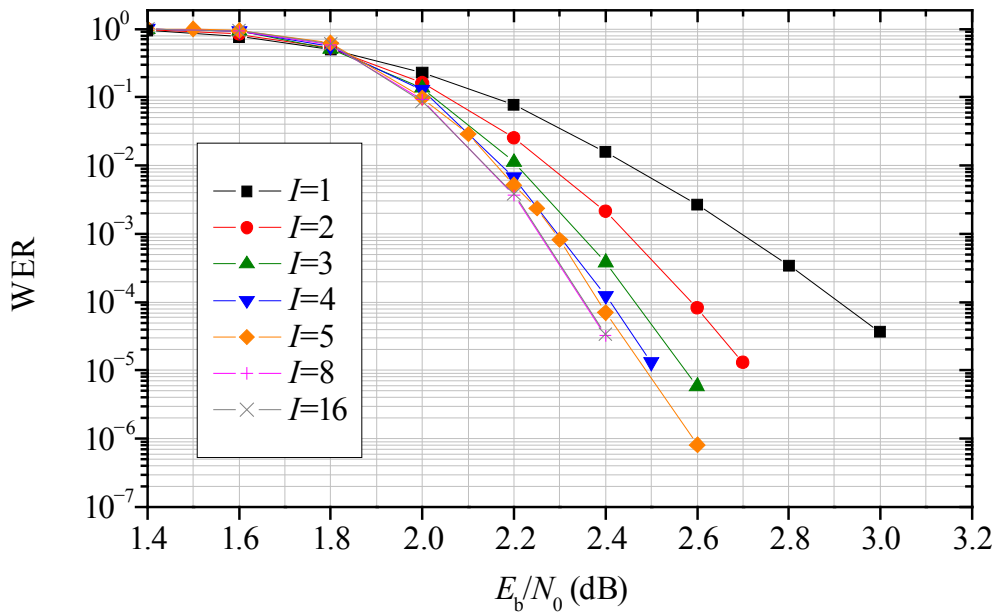

Figure 6-8: Word Error Rate Simulated Performance of the CCSDS Concatenated Scheme with Outer $E=16$ Reed-Solomon Code (255,223) and Inner Rate-1/2 Convolutional Code as a Function of Interleaving Depth

Figures 6-7 and 6-8 illustrate how interleaving depth $I=5$ obtains near-ideal performance. This amount of interleaving is also sufficient to obtain near-ideal performance for most other combinations of recommended RS and convolutional codes.

Figures 6-9 and 6-10 show BER and WER for the recommended concatenated system consisting of the non-shortened (255,239) RS code with $E=8$ and the non-punctured (7, 1/2) convolutional code, with different interleaving depths ranging from $I=1$ to $I=16$.

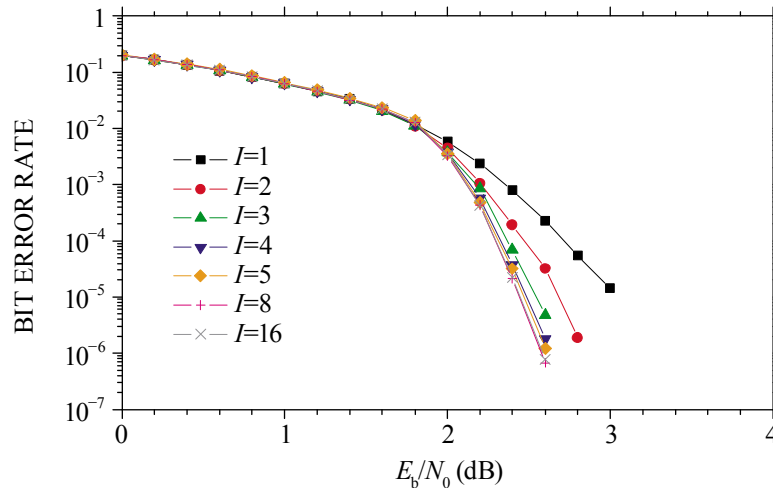

Figure 6-9: Bit Error Rate Simulated Performance of the CCSDS Concatenated Scheme with Outer $E=8$ Reed-Solomon Code (255,239) and Inner Rate-1/2 Convolutional Code as a Function of Interleaving Depth

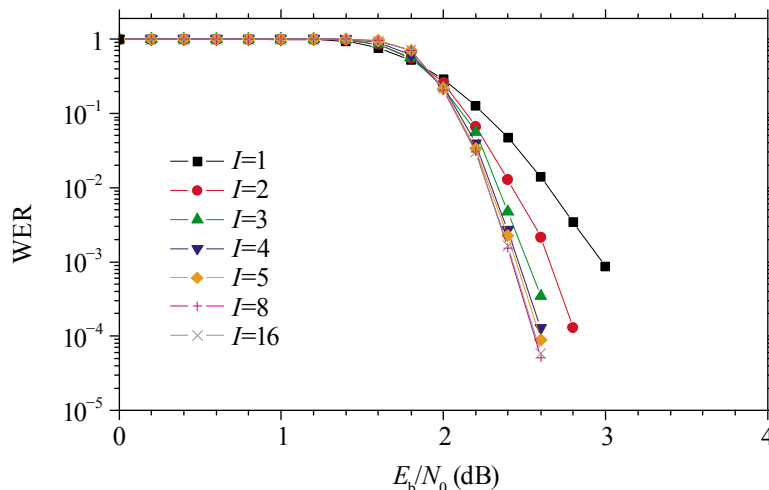

Figure 6-10: Word Error Rate Simulated Performance of the CCSDS Concatenated Scheme with Outer $E=8$ Reed-Solomon Code (255,239) and Inner Rate-1/2 Convolutional Code as a Function of Interleaving Depth

Figures 6-11 and 6-12 show BER and WER curves for the concatenated codes consisting of the non-shortened (255,223) RS code with $E = 16$ concatenated with any of the recommended punctured or non-punctured (7, 1/2) convolutional codes, with interleaving depth $I = 5$ (which gives a close approximation to ideal performance on the AWGN channel).

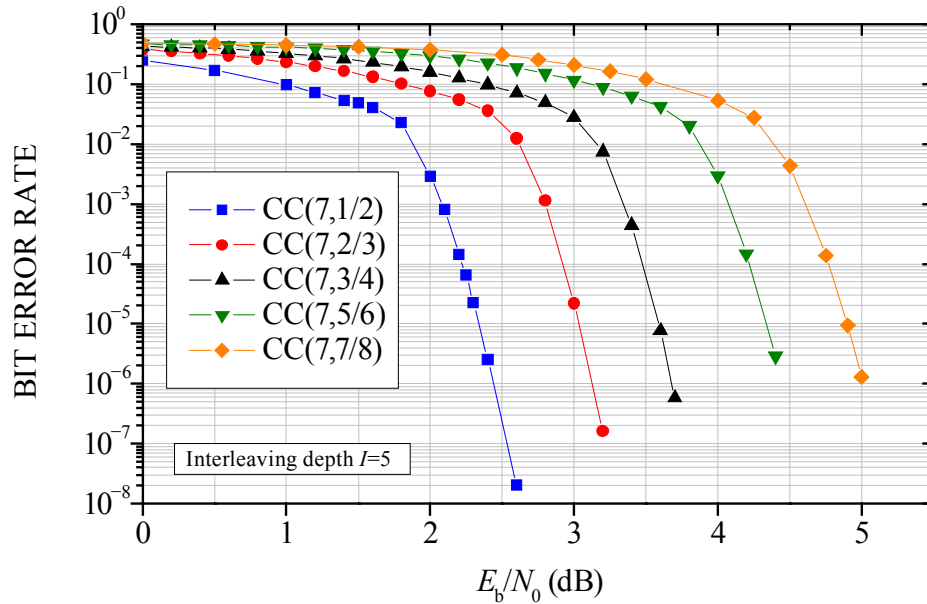

Figure 6-11: Bit Error Rate Simulated Performance of the CCSDS Concatenated Scheme with Outer $E=16$ Reed-Solomon Code (255,223) and Inner Punctured Convolutional Codes, Using Finite Interleaving with $I=5$

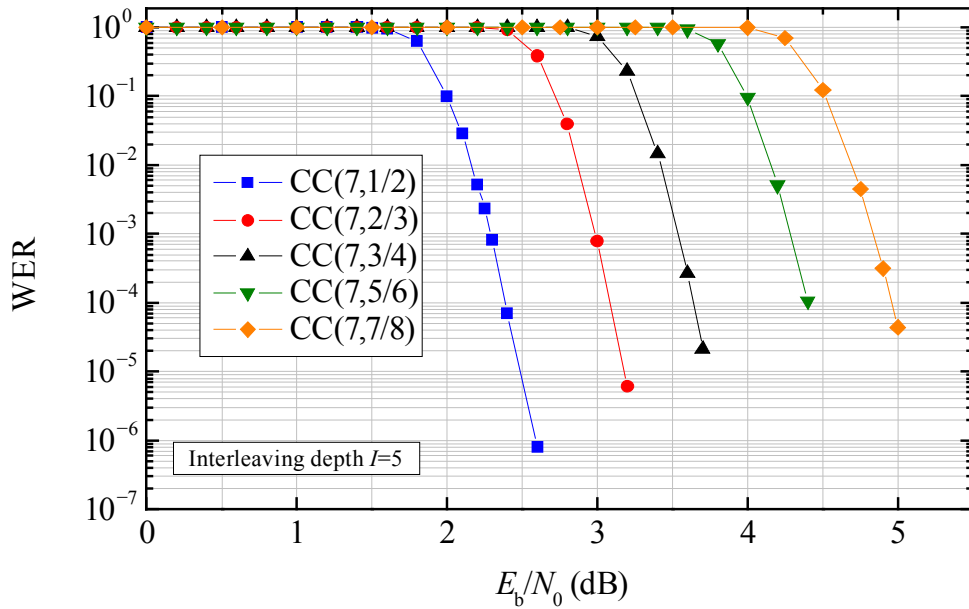

Figure 6-12: Word Error Rate Simulated Performance of the CCSDS Concatenated Scheme with Outer $E=16$ Reed-Solomon Code (255,223) and Inner Punctured Convolutional Codes, Using Finite Interleaving with $I=5$

Figures 6-13 and 6-14 show BER and WER curves for the concatenated codes consisting of the non-shortened (255, 239) RS code with $E=8$ concatenated with any of the recommended punctured or non-punctured (7, 1/2) convolutional codes, with interleaving depth $I=5$ (which gives a close approximation to ideal performance on the AWGN channel).

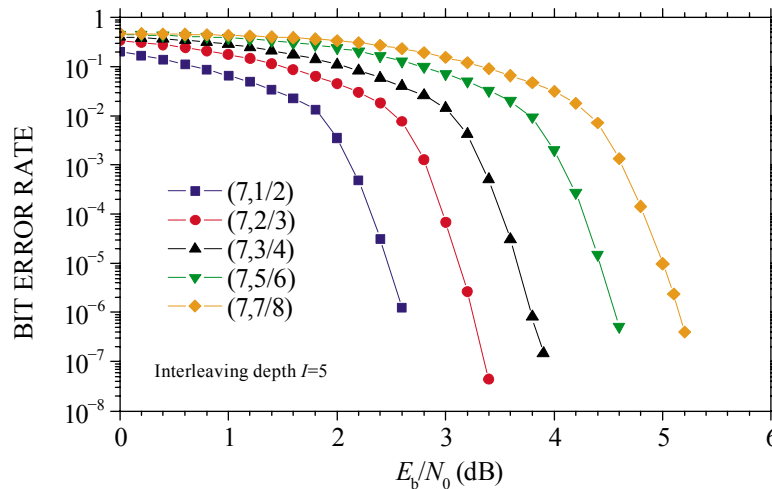

Figure 6-13: Bit Error Rate Simulated Performance of the CCSDS Concatenated Scheme with Outer $E=8$ Reed-Solomon Code (255,239) and Inner Punctured Convolutional Codes, Using Finite Interleaving with $I=5$

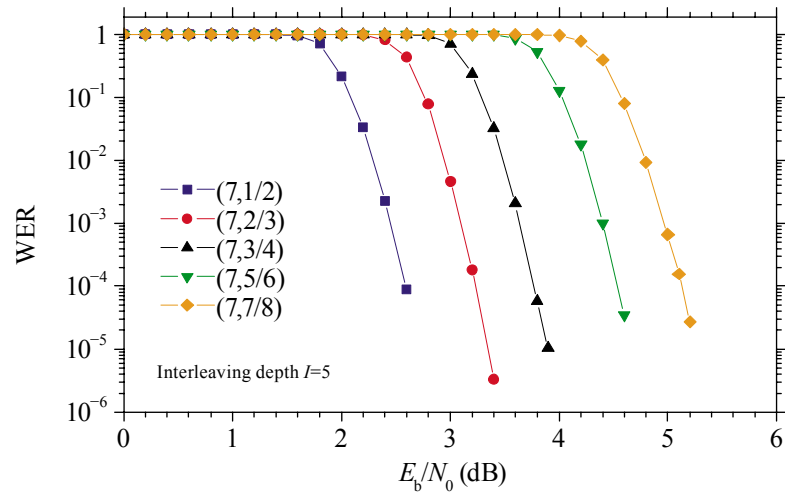

Figure 6-14: Word Error Rate Simulated Performance of the CCSDS Concatenated Scheme with Outer $E=8$ Reed-Solomon Code (255,239) and Inner Punctured Convolutional Codes, Using Finite Interleaving with $I=5$

7 TURBO CODES

7.1 INTRODUCTION

In 1993, a new class of concatenated codes called ‘Turbo codes’ was introduced. These codes can achieve near-Shannon-limit error correction performance with reasonable decoding complexity. Turbo codes outperformed even the most powerful codes known at that date, but more importantly, they were much simpler to decode. It was found that good Turbo codes can come within approximately 0.8 dB of the theoretical limit at a BER of 10^{-6} .

A Turbo code is a combination of two simple recursive convolutional codes, each using a small number of states. These simple convolutional codes are in fact ‘terminated’ convolutional codes and hence block codes. For a block of k information bits, each constituent code generates a set of parity bits. The Turbo code consists of the information bits and both sets of parity, as shown in figure 7-1.

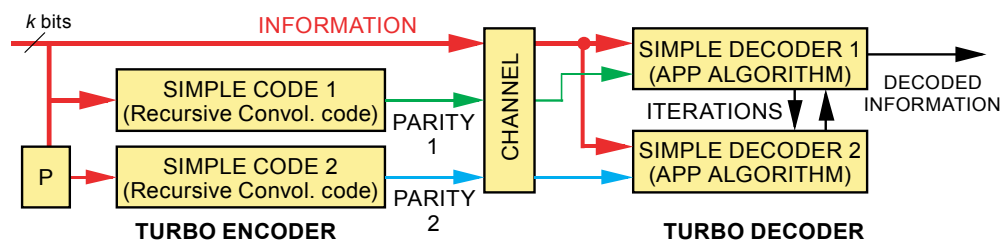

Figure 7-1: Example of Turbo Encoder/Decoder

The key innovation is an interleaver P , which permutes the original k information bits before encoding the second code. If the interleaver is well-chosen, information blocks that correspond to error-prone codewords in one code will correspond to error-resistant codewords in the other code. The resulting code achieves performance similar to that of Shannon’s well-known ‘random’ codes, but random codes approach optimum performance only at the price of a prohibitively complex decoder.

Turbo decoding uses two simple decoders individually matched to the simple constituent codes. Each decoder sends likelihood estimates of the decoded bits to the other decoder and uses the corresponding estimates from the other decoder as a-priori likelihoods. The constituent decoders use the A Posteriori Probability (APP) bitwise decoding algorithm, which requires the same number of states as the well-known Viterbi algorithm. The Turbo decoder iterates between the outputs of the two decoders until reaching satisfactory convergence. The final output is a hard-quantized version of the likelihood estimates of either of the decoders.

To achieve maximum performance, Turbo codes use large block lengths and correspondingly large interleavers. The size of the interleaver affects buffer requirements and decoding latency, but has little impact on decoding speed or decoder complexity. More recently, it was discovered that Turbo codes with shorter blocks also perform amazingly well with respect to

the theoretical performance bounds on codes constrained to have a given block length. Thus Turbo codes can also offer good performance for applications requiring small block sizes on the order of a few hundreds of bits (but these block sizes are not within the scope of the Recommended Standard (reference [3])).

7.2 TURBO ENCODER

A Turbo encoder is a combination of two simple encoders. The input is a frame of k information bits. The two component encoders generate parity symbols from two simple recursive convolutional codes, each with a small number of states. The information bits are also sent uncoded. An interleaver permutes bit-wise the original k information bits before input to the second encoder. A generic implementation block diagram for a Turbo encoder is shown in figure 7-2. The specific Turbo encoder in the CCSDS Recommended Standard (reference [3]) is shown in more detail in figure 7-3.

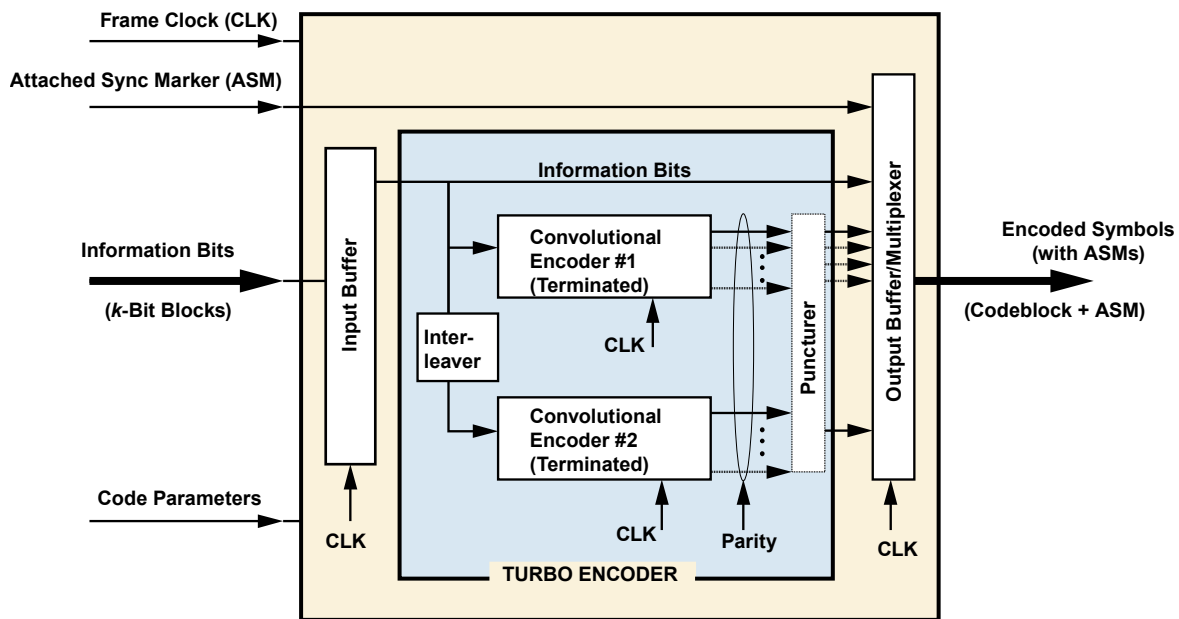

Figure 7-2: Block Diagram of Turbo Encoder

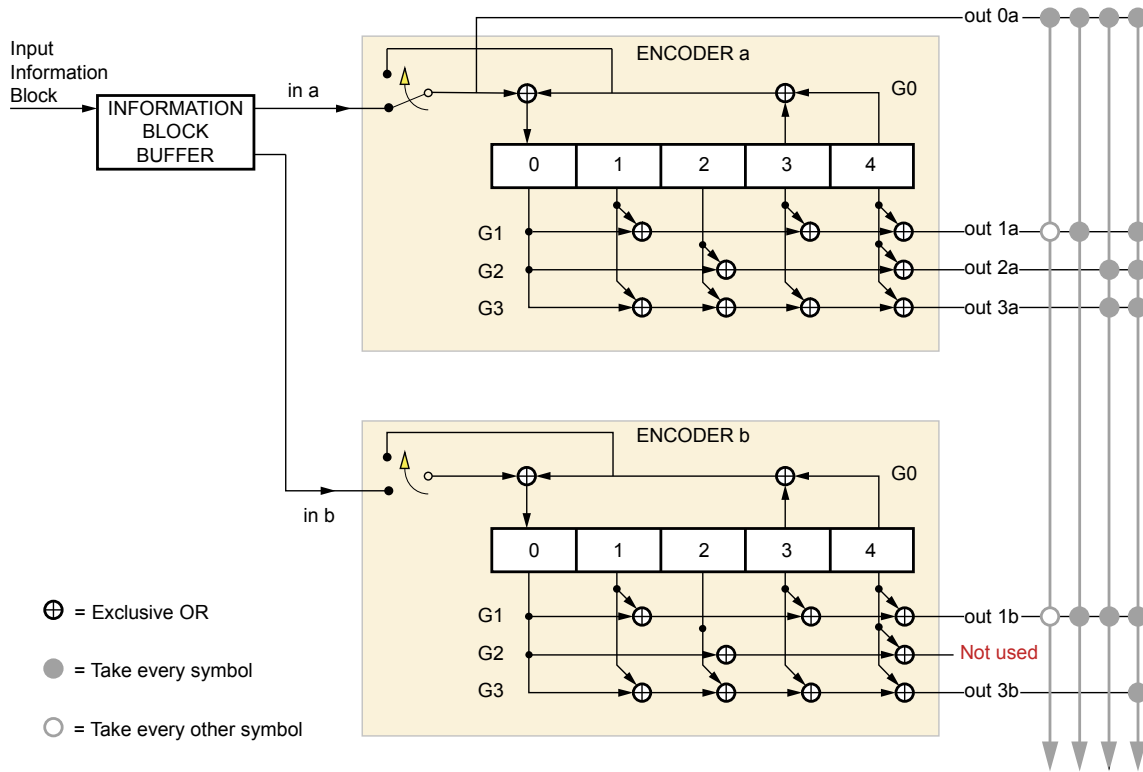

Figure 7-3: CCSDS Turbo Encoder Block Diagram

The two convolutional encoders in the Recommended Standard (reference [3]) are recursive with constraint length $K=5$ and are realized by feedback shift registers. However, unlike the encoder for the recommended plain convolutional code in section 4, the Turbo codeword is terminated by running each encoder for additional $K-1$ bit times beyond the end of the information bit frame. After encoding the last bit in the frame, the leftmost adder in each component encoder receives two copies of the same feedback bit, causing it to ‘zero’ its output. After $K-1$ more bit times, all 4 memory cells become filled with ‘zeros’, but in the interim, the encoder continues to output nonzero encoded symbols.

The Recommended Standard (reference [3]) allows options for non-punctured codes with rates between $1/3$, $1/4$, and $1/6$. The puncturer is used only for code rate $1/2$.

The interleaver in the Recommended Standard (reference [3]) is based on a permutation rule that can be computed on-the-fly or pre-computed and stored in a look-up table, for all allowable frame lengths (1784 to 16384 bits).

In figure 7-3, CLK indicates the frame clock. It is used (1) by the input buffer to determine when to empty and refill the buffer; (2) by the output buffer/multiplexer to determine when to insert the frame sync marker; and (3) by each of the convolutional encoders to determine when to terminate the codeword. It should be noted that an entire information block of k bits must be read in before the encoding can proceed because some of the bits in the tail end of block will be permuted to the front and need to be encoded first. Thus there is a fundamental encoding latency of at least k bits in the encoding process.

The Turbo code introduces a couple of unique encoder complexity issues. The information block needs to be buffered and read out in a permuted order as part of the encoding process. This buffering has no analog in the plain convolutional encoder, but the size of this buffer is comparable to that required for an interleaved RS codeblock of the same size. The difference is that the traditional concatenated coding architecture completely separates the RS encoder (with its associated buffer) from the convolutional encoder. Thus the Turbo encoder cannot be regarded as a plug-in replacement for the convolutional encoder hardware. The Turbo encoder actually replaces the RS/convolutional encoder combination.

Another complexity consideration is how to implement the permutation. The best permutations for Turbo codes look very random, but this requires specifying a random-looking readout order via a ROM (table look-up). An alternative is to use a permutation that can be generated by a simple rule rather than from a lookup table, with minor performance sacrifice. The Recommended Standard (reference [3]) specifies a permutation based on a simple rule because it was preferred in terms of implementation on the spacecraft.

7.3 TURBO DECODER

A Turbo decoder uses an iterative decoding algorithm based on simple decoders individually matched to the two simple constituent codes. Each constituent decoder makes likelihood estimates derived initially without using any received parity symbols not encoded by its corresponding constituent encoder. The (noisy) received uncoded information symbols are available to both decoders for making these estimates. Each decoder sends its likelihood estimates to the other decoder and uses the corresponding estimates from the other decoder to determine new likelihoods by extracting the ‘extrinsic information’ contained in the other decoder’s estimates based on the parity symbols available only to it. Both decoders use the APP bitwise decoding algorithm, which requires the same number of states as the well-known Viterbi algorithm. The Turbo decoder iterates between the outputs of the two constituent decoders until reaching satisfactory convergence. The final output is a hard-quantized version of the likelihood estimates of either of the decoders.

The Recommended Standard (reference [3]) does not include a detailed description of the specific Turbo decoding algorithm. However, the performance curves in 7.4 for the Turbo code family in the Recommended Standard (reference [3]) were obtained using a decoding algorithm with the following characteristics:

- a) decoder type: Iterative ‘Turbo’ decoding using two 16-state component decoders (see reference [18]);
- b) type of component decoders: soft-input, soft-output APP decoders (see reference [19]);
- c) quantization of channel symbols: at least 6 bits/symbol;
- d) quantization of decoder metrics: at least 8 bits;
- e) number of decoder iterations: variable depending on signal-to-noise ratio.

Variations from this algorithm will result in performance tradeoffs.

The overall Turbo decoding procedure is depicted in figure 7-1 and described earlier. The ‘simple decoders 1 and 2’ each compute likelihood estimates (APP estimates) based on a version of the APP or log-APP algorithm,⁷ as described in reference [14]. A diagram showing the structure of the Turbo decoder in more detail is shown in figure 7-4. Figure 7-5 shows the basic circuits needed to implement the log-APP algorithm.

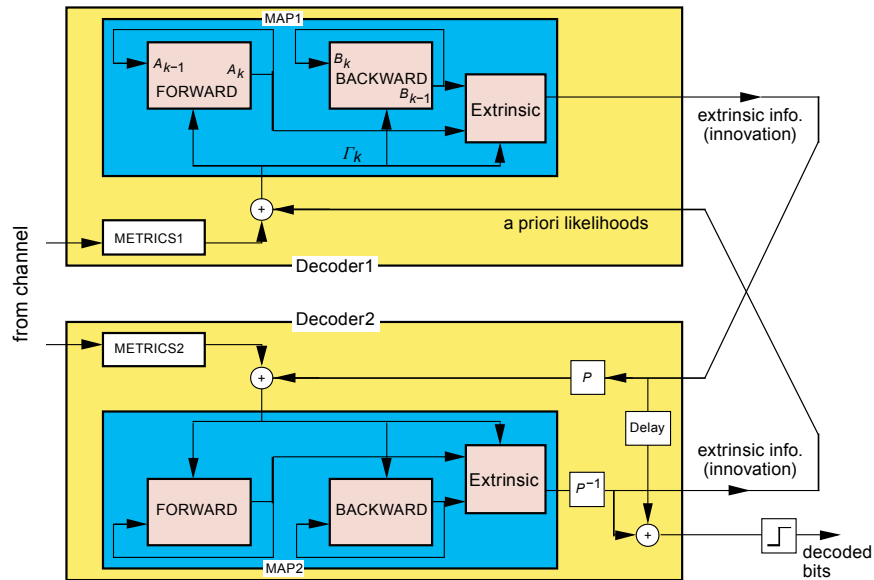

Figure 7-4: Structure of the Turbo Decoder

⁷ In the early Turbo coding literature, the APP algorithm was designated as the MAP (maximum a posteriori) algorithm because it was derived from a homonymous algorithm for making optimum bit-wise hard decisions on plain convolutionally encoded symbols.

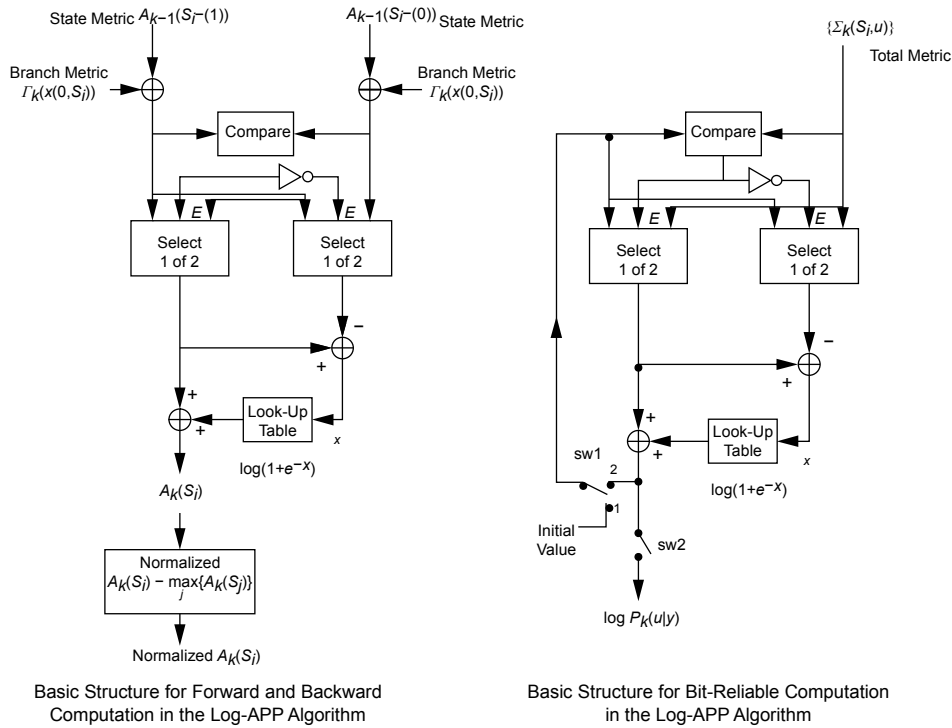

Figure 7-5: Basic Circuits to Implement the Log-APP Algorithm

Because the decoder processes whole blocks of k bits at a time, there is a minimum decoding latency of k bits. This latency is further increased by the time required for the decoder to process each block. Because the decoder processes whole blocks of k bits at a time, there is a minimum decoding delay of k bits. This latency is further increased by the time required for the decoder to process each block. If parallel decoders are used to increase decoding throughput, the latency of the system (when measured in bits) increases in proportion to the number of parallel decoders. For example, two decoders that can process up to x bits/sec, with a latency of t seconds, in parallel could process up to $2x$ bits/sec, but the latency is still t seconds, or $2xt$ bits.

To first order, the decoding complexity of a Turbo decoder relative to that of a convolutional decoder using the *same* number of trellis states and branches can be estimated by multiplying several factors: (a) a factor of 2 because the Turbo code uses two component decoders; (b) another factor of 2 because the individual decoders use forward and backward recursions compared to the Viterbi decoder's forward-only recursion; (c) another small factor because the Turbo decoder's recursions require somewhat more complex calculations than the Viterbi decoder's; and (d) a factor to account for the Turbo decoder's multiple iterations compared to the Viterbi decoder's single iteration. The relative decoding complexity for two *different* Turbo codes or two *different* convolutional codes can be estimated by multiplying two additional factors: (e) the number of trellis states and (f) the number of trellis branches per input bit into each state. Factor (c) can be reduced to one by implementing an approximate log-MAP algorithm at a small sacrifice in performance. Factors (b) and (d) might be reduced on the average by using a more advanced Turbo decoding algorithm, using stopping rules, or

using different iteration schedules. Such an algorithm might allow the decoder to stop its iterations early if a given codeword can already be decoded reliably, or to skip over portions of the forward and backward recursions for some iterations. Factors (a) through (d) are 1 for Viterbi decoders of convolutional codes. For the CCSDS standard constraint-length-7 convolutional decoder, factor (e) is $2^6=64$, and factor (f) is $2/1=2$. For the Cassini/Pathfinder constraint-length 15, rate 1/6 convolutional decoder, factor (e) is $2^{14}=16384$, and factor (f) is $6/1=6$. For the Turbo codes specified in 7.2, factor (e) is $2^4=16$, and factor (f) ranges from $2/1=2$ to $6/1=6$.

A basic form of Turbo decoder stops iterating after a predetermined number of iterations. For some codewords (or sections of codewords), the predetermined number of iterations may be too many or too few. A more efficient Turbo decoder can employ a stopping rule to stop the decoder's iterations when convergence is satisfactory, that is, without wasting iterations when the decoder has already converged, and without halting iterations prematurely when the decoder needs a little more time. Such a rule reduces the *average* number of iterations and increases the average decoding throughput, at the expense of a slightly more complicated decoding algorithm and increased decoder buffering requirements to accommodate variable decoding times.

7.4 PERFORMANCE OF THE RECOMMENDED TURBO CODES

7.4.1 SIMULATED TURBO CODE PERFORMANCE CURVES

Figures 7-6, 7-7, 7-8, and 7-9 show the simulated performance of the recommended Turbo codes of rates 1/2, 1/3, 1/4, and 1/6, constructed for information block lengths of 1784, 3568, 7136, and 8920 bits. For all of the results in these figures, the decoder used a fixed-iteration stopping rule and stopped after 10 iterations.

To achieve a BER of 10^{-6} , threshold bit-SNRs of approximately -0.1 dB, 0.15 dB, 0.4 dB, and 1.1 dB, are required by the Turbo codes of rates 1/6, 1/4, 1/3, and 1/2, respectively. Approximately the same threshold bit-SNRs achieve a WER or FER of 10^{-4} for these codes. (It may be noted that $WER=FER$ for the CCSDS Turbo codes because the Turbo code's information block corresponds to one CCSDS frame.)

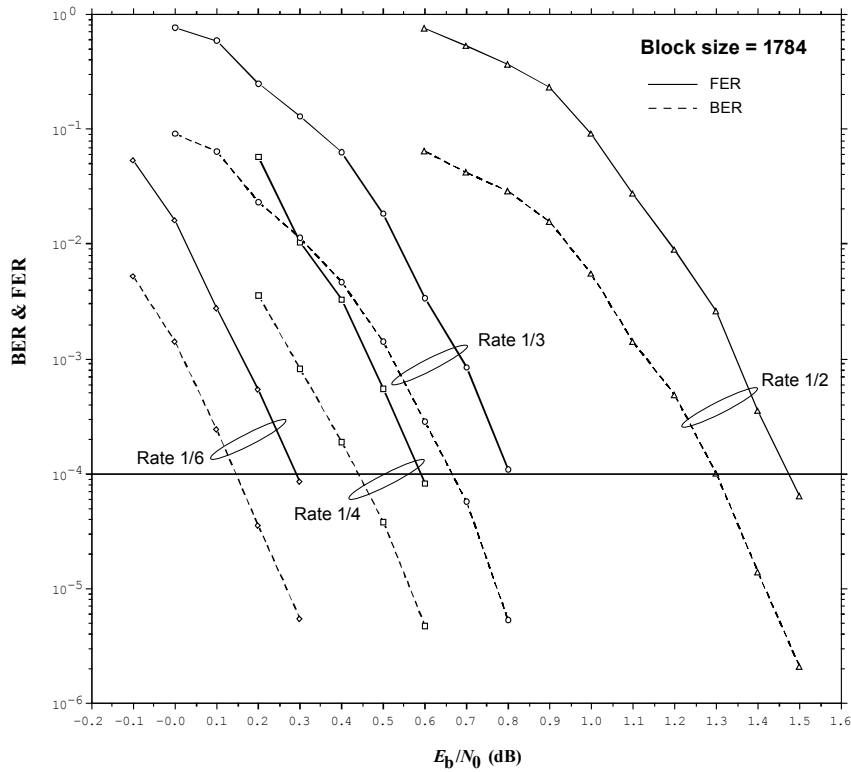

Figure 7-6: BER and FER Performance for Rate 1/2, 1/4, 1/3, and 1/6 Turbo Codes with Block Size 1784 Bits, Measured from JPL DSN Turbo Decoder, 10 Iterations

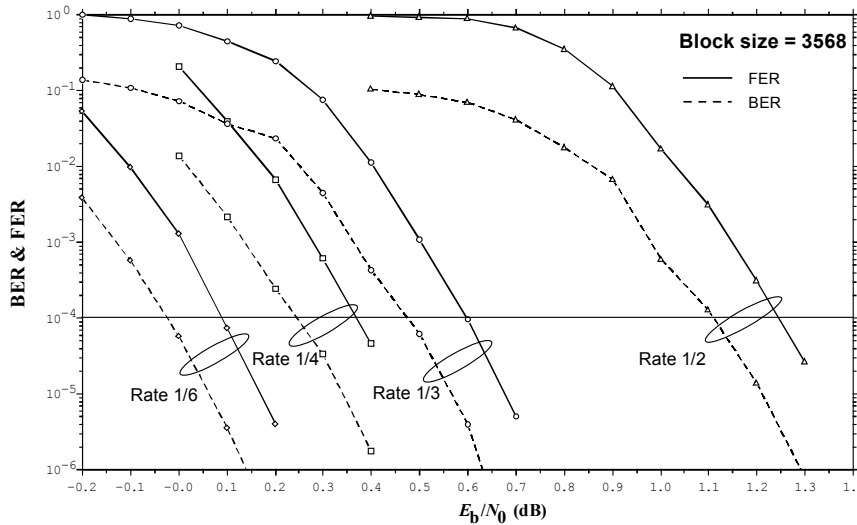

Figure 7-7: BER and FER Performance for Rate 1/2, 1/4, 1/3, and 1/6 Turbo Codes with Block Size 3568 Bits, Software Simulation, 10 Iterations⁸

⁸ Performance of hardware decoder not available.

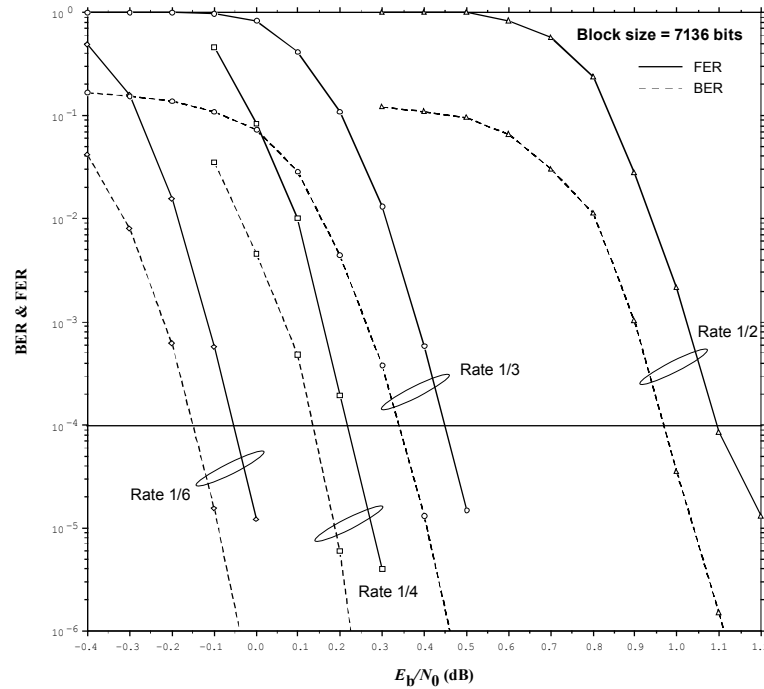

Figure 7-8: BER and FER Performance for Rate 1/2, 1/4, 1/3, and 1/6 Turbo Codes with Block Size 7136 bits, Software Simulation, 10 Iterations⁶

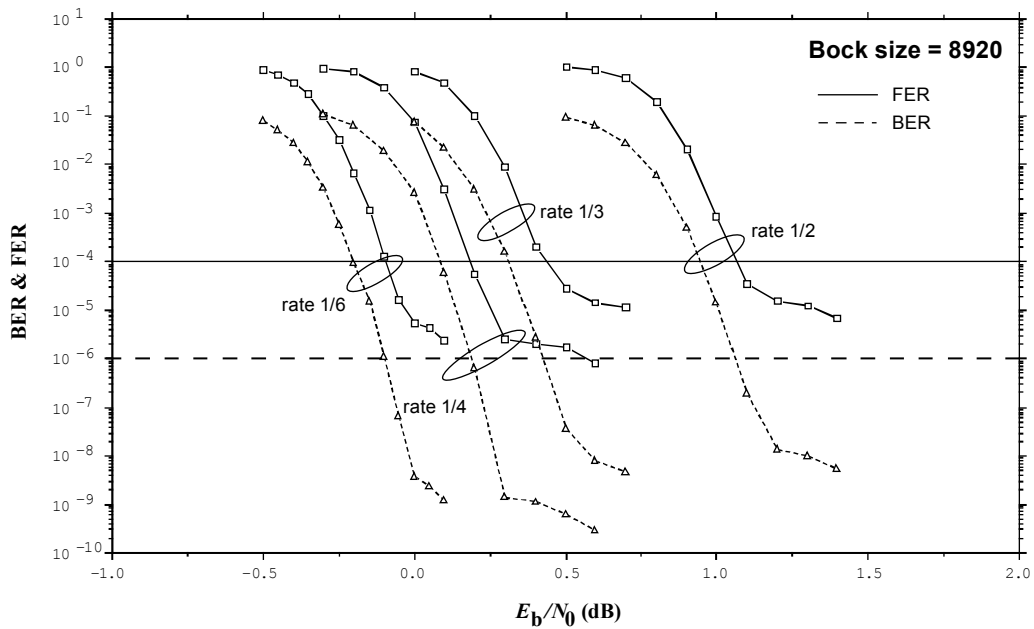

Figure 7-9: BER and FER Performance for Rate 1/2, 1/4, 1/3, and 1/6 Turbo Codes with Block Size 8920 Bits, Measured from JPL DSN Turbo Decoder, 10 Iterations

Figure 7-10 shows the simulated performance of Turbo codes of rates 1/2, 1/3, 1/4, and 1/6, with an information block length of 16384 bits. These performance curves do not necessarily reflect the performance of the CCSDS codes for this block length since the recommended interleaver for this block length has not been specified yet.

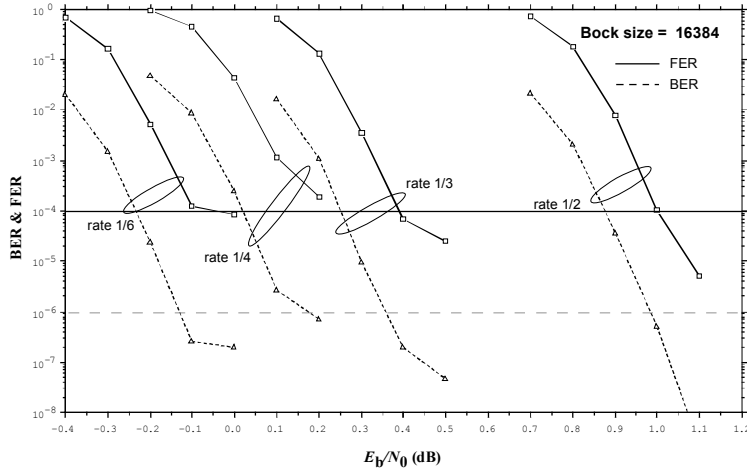

Figure 7-10: BER and FER Performance for Rate 1/2, 1/4, 1/3, and 1/6 Turbo Codes, Block Size 16384 Bits, Software Simulation, 10 Iterations

Figure 7-11 illustrates how the decoder’s average speed can be increased through the use of stopping rules.

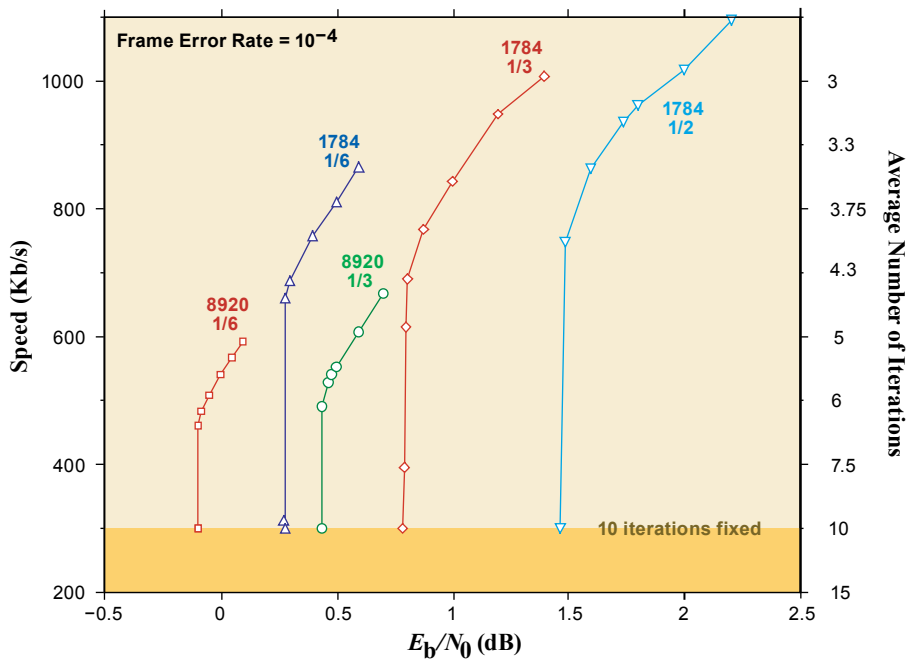

Figure 7-11: Illustration of Decoder Speedup Using Stopping Rules

The x -axis shows the threshold value of E_b/N_0 required to reach a FER of 10^{-4} . The y -axis shows the average decoding speed, or reciprocally the average number of iterations. In this figure, a decoder using a fixed 10 iterations achieves a speed of 300 Kb/s, and the decoder's average speed increases inversely as the average number of iterations is reduced by application of the stopping rule. The results in this figure are for a selection of recommended Turbo codes with block lengths 1784 and 8920. The figure shows that effective stopping rules can increase the decoder speed on the order of 50% to 100% with virtually no compromise in the required value of E_b/N_0 ; further increases in speed can also be obtained by trading off additional SNR for increased speed.

7.4.2 COMPARISON TO TRADITIONAL CONCATENATED CODES

Turbo codes gain a significant performance improvement over the traditional RS and convolutional concatenated codes currently recommended by CCSDS. For example, to achieve an overall BER of 10^{-6} with a block length of 8920 bits (depth-5 interleaving), the required bit-SNRs are approximately 0.8 dB, 1.0 dB, and 2.6 dB for the DSN's standard codes consisting of the (255,223) RS code concatenated with the (15,1/6) convolutional code, the (15,1/4) convolutional code, and the (7,1/2) convolutional code, respectively. The performance gains achieved by the corresponding-rate Turbo codes in figures 7-6, 7-7, 7-8, 7-9, and 7-10 range from 0.9 dB to 1.6 dB.

Figure 7-12 compares the performance of the recommended Turbo codes of block length 1784 bits and rates 1/3 and 1/6 with the performance of the CCSDS concatenated code used by Voyager and that of the non-CCSDS concatenated code used by Cassini and Mars Pathfinder. The Voyager code consists of the recommended concatenation of the (255, 223) RS code with the (7,1/2) convolutional code. The Cassini/Pathfinder code consists of the same RS code concatenated with a (15, 1/6) convolutional code for which the Viterbi decoder requires $2^8 = 256$ times as many states as for the (7, 1/2) code. Performance for both concatenated codes is obtained using an interleaving depth of $I=1$, not the actual interleaving depths used in the Voyager/Cassini/Pathfinder missions, in order to provide a fair comparison with the performance of the two Turbo codes with block length 1784. In other words, a frame length of 1784 bits is assumed for all four curves in this figure.

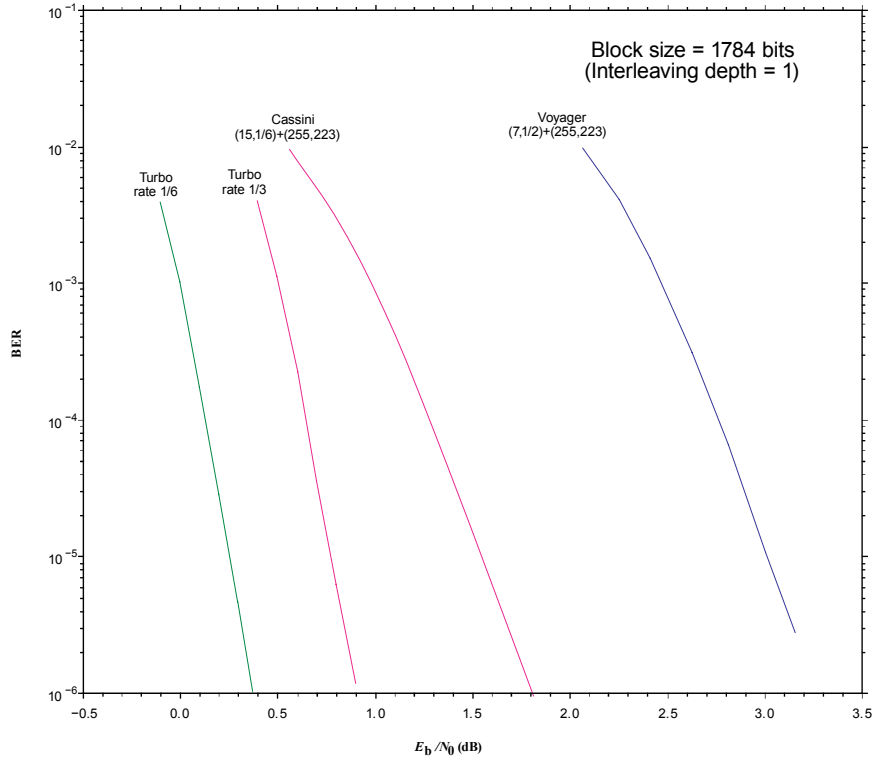

Figure 7-12: BER Performance of Turbo Codes Compared to Older CCSDS Codes (Except Cassini/Pathfinder Code: Reed-Solomon (255,223) + (15,1/6) Convolutional Code), Block Size 1784 Bits (Interleaving Depth = 1), Software Simulation, 10 Iterations

Figure 7-13 compares the performance of the recommended Turbo codes of block length 8920 bits and rates 1/3 and 1/6 with the performance of the Voyager and Cassini/Pathfinder concatenated codes, now allowed to have interleaving depth $I=5$ in order to produce equal-length frames of 8920 bits for all codes shown.

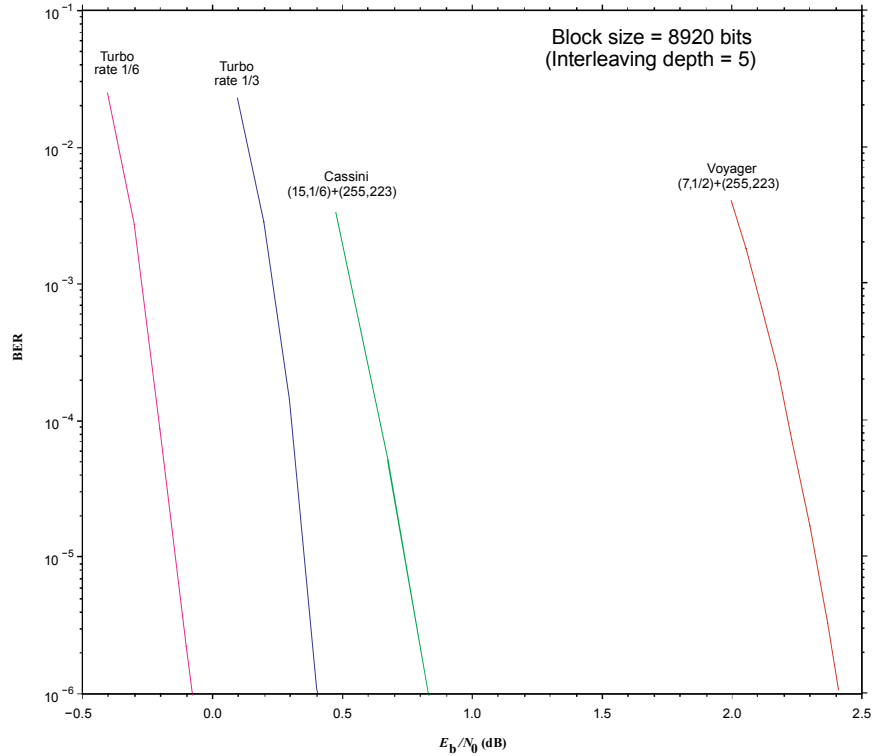

Figure 7-13: BER Performance of Turbo Codes Compared to Older CCSDS Codes (Except Cassini/Pathfinder Code: Reed-Solomon (255,223) + (15,1/6) Convolutional Code), Block Size 8920 Bits (Interleaving Depth = 5), Software Simulation, 10 Iterations

7.4.3 THE TURBO DECODER ERROR FLOOR

Although Turbo codes can be found to approach the Shannon-limiting performance at very small required BERs, the Turbo code’s performance curve does not stay steep forever as does that of a convolutional/RS concatenated code. When it reaches the so-called ‘error floor’, the curve flattens out considerably and looks from that point onward like the performance curve for a weak convolutional code. In the error floor region, the weakness of the constituent codes takes charge, and the performance curve flattens out from that point onward. The error floor is not an absolute lower limit on achievable error rate, but it is a region where the slope of the Turbo code’s error rate curve becomes dramatically poorer.

There exist transfer function bounds on Turbo code performance (reference [14]) that accurately predict the actual Turbo decoder’s performance in the error floor region above the so-called ‘computational cutoff rate’ threshold, below which the bounds diverge and are useless. More advanced bounds that are tight at lower values of bit SNR were developed in reference [29]. These bounds are computed from the code’s weight enumerator, which is not readily available for the recommended Turbo codes. Approximations valid in the error floor region can be obtained from considering only codewords of the lowest weight(s). Reference [30] gives a method for calculating the minimum distance of the recommended

codes and the corresponding estimates of BER on the error floor. Other details on algorithms for computing CCSDS Turbo code minimum distance and error floors can be found in reference [32].

Figure 7-14 provides an illustration of the transition of a Turbo code performance curve from a steep ‘waterfall’ region into a much flatter ‘error floor’ region for two Turbo codes analyzed as an example. This figure shows the actual simulated Turbo code performance compared with bounds approximating the error floor.

The original Turbo codes of Berrou, et al. (reference [17]) had error floors starting at a BER of about 10^{-5} . By using theoretical predictors as guides, it was possible to design the Turbo codes in the Recommended Standard (reference [3]) so as to lower the error floor to possibly insignificant levels (e.g., as low as 10^{-9} BER).

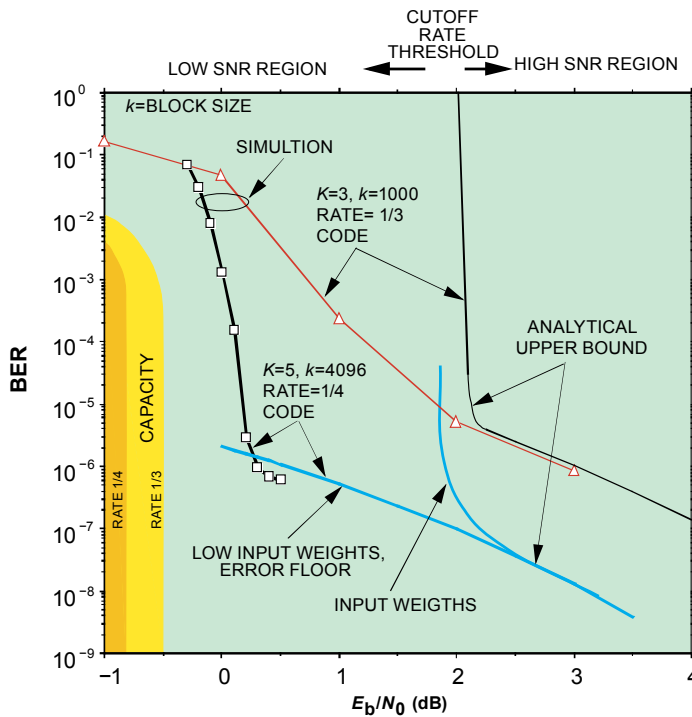

Figure 7-14: Illustration of Turbo Code Error Floor

7.4.4 PERFORMANCE IN THE PRESENCE OF BURST NOISE

While a good turbo decoder provides performance close to the capacity limit with Independent and Identically Distributed (IID) noise, the codes are vulnerable to burst noise. While spacecraft communication is sometimes cited as an essentially perfect IID channel, experience shows that the dominant error sources are commonly bursty, and are associated either with the transmit or receive equipment. An extreme example is the ‘tumbling spacecraft’ scenario, in which a spacecraft does not have sufficient attitude control to maintain an Earth-pointed antenna. Other sources of burst noise may include transient radio-frequency interference, phase recovery errors in the symbol- or carrier-tracking loops, and so on.

This weakness in the presence of burst noise is inherited from the underlying convolutional codes and is intrinsic to the code construction, so it cannot be resolved by a change to the decoder alone. An effective solution would be to add a ‘channel interleaver’ after the turbo encoder, and a matching de-interleaver before the decoder, to distribute the errors about uniformly over the length of the codeword, though CCSDS has not specified such an interleaver.

The erasure channel is sufficient to illustrate the weakness, and lends itself to simple analysis. On this channel, a turbo decoder alternately considers the two constituent convolutional codes and determines which paths through the trellises are consistent with the known symbols. At each iteration, either additional message bits are determined, or progress ceases; the decoder never changes a previously determined bit. Decoding success depends only on the locations of the erasures, not on the values of the known (unerased) symbols. The locations of the code symbols that remain unresolved when progress ceases is called a stopping set. As shown by the following analysis, and as confirmed by simulation, erasures that are grouped into bursts are far more likely to contain a stopping set than erasures that are distributed more uniformly over the codeword.

By linearity of the turbo codes, if the all-zero codeword is sent, each code symbol in a stopping set remains undetermined because it might belong to a nonzero codeword of the corresponding constituent convolutional code. Formally, for convolutional encoder a , with c_a being a codeword that corresponds to message m_a , C_a and M_a being the support sets for c_a and m_a (the indices of the 1s), and likewise for the second encoder, b , of a turbo code, if $\pi(\cup_i \{M_{a,i}\}) = \cup_j \{M_{b,j}\}$, where π is the turbo code’s interleaver function, then $(\cup_i \{C_{a,i}\}) \cup (\cup_j \{C_{b,j}\})$ is a stopping set (reference [71]).

If a codeword contains a single burst of erasures, then a stopping set can be described more directly (reference [72]). The unrecoverable message bit indices, M_a , must lie within the burst, and their permuted indices, M_b , must also lie within the burst. In addition, for each trellis, there must be some path that uses each message bit and some subset of the others to return to the zero state. Supposing that a burst erases a fraction p of a codeword, about kp message bits lie within that burst, and with a uniform interleaver, about kp^2 of them also have their permuted locations within the burst. It turns out that if $kp^2 \geq v + 2$, where v is the constraint length of the convolutional code and a primitive polynomial denominator is assumed, then it is probable that each message bit participates in some trellis path that returns to the zero state.

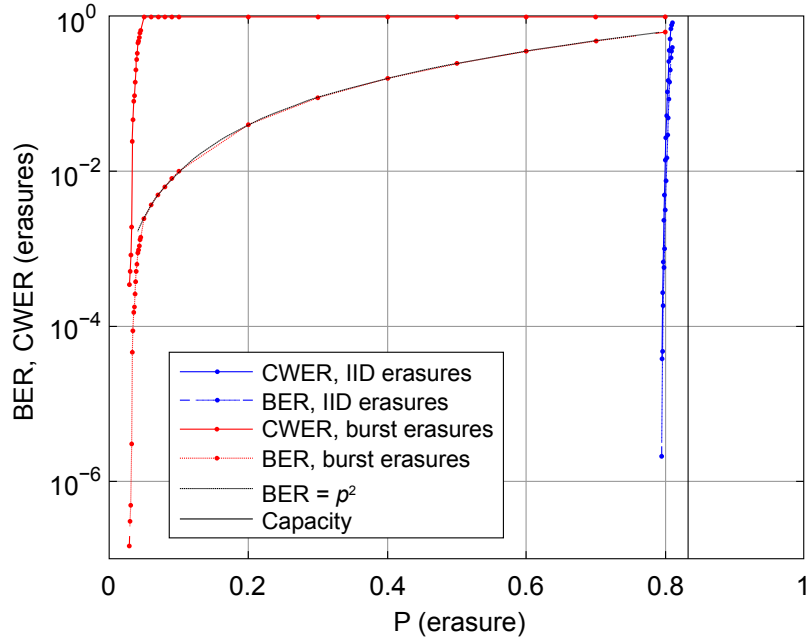

Figure 7-15: Performance of the (3568,1/6) Turbo Code with Erasures Either Uniformly Distributed or Grouped in a Single Burst

It can be concluded that a burst with a fractional length $p > \sqrt{(v+2)/k}$ is likely to contain a stopping set, and turbo decoding will fail. In this region, the codeword erasure rate is near unity. Moreover, in this region, about kp^2 message bits are unrecoverable out of k message bits in the codeword, resulting in a bit erasure rate of about p^2 . Figure 7-15 shows simulated bit- and codeword-erasure rates for the ($k=3568$, $r=1/6$) turbo code, both over the IID erasure channel, and over the channel where all the symbol erasures occur in a single burst. Also shown is the analytic result, $BER=p^2$ for $p > \sqrt{(v+2)/k}$ (a quadratic curve on a logarithmic axis), and the capacity limit, $p < 5/6$. These burst-erasure performance curves depend little on the turbo code in use. More precisely, only the transition threshold, $p = \sqrt{(v+2)/k}$, depends on the codeword length and constraint length of the constituent convolutional codes; below that, both the BER and CWER are zero, and above that, $BER=p^2$ and $CWER=1$, independent of the turbo code used.

8 LDPC CODES

8.1 GENERAL

The mid-1990s were highlighted by the rediscovery of Low Density Parity Check (LDPC) codes in the field of channel coding (reference [33]). Originally invented by R. Gallager in his PhD thesis in 1961 (reference [34]), this coding technique was largely forgotten for more than 30 years. The primary advance in LDPC coding is the discovery of an iterative decoding algorithm, now called Belief Propagation (BP), which offers near-optimum performance for large linear LDPC codes at a manageable complexity. LDPC code performance gains were difficult to realize technologically in the early 1960s. Several decades of VLSI development have finally made the implementation of these codes practical.

The original construction, now called Gallager codes, has come to be regarded as a special class of LDPC codes. Recent advances in LDPC code construction have resulted in the development of new codes with improved performance over Gallager codes. One class of these codes, irregular LDPC codes (reference [35]), demonstrates improved performance in the waterfall region. Disadvantages of irregular codes, however, include an increase, in general, in the number of iterations required for decoding convergence and an unequal error protection between code bits resulting from the irregular structure. Another class of LDPC codes developed using algebraic construction based on finite geometries (reference [36]) has been shown to provide very low error floors and very fast iterative convergence.

The following two sets of LDPC codes have been proposed because the former is optimized for high rates (Near Earth) and the latter for very low SNR (Deep Space):

1. In the Near Earth case, data is transmitted at many hundreds of Mb/s in a band restricted to 375 MHz. A high rate code is needed to limit bandwidth expansion. Complexity must be limited to allow high data rate encoding and decoding. The number of decoding iterations must be low to allow the high data rate; hence convergence must be fast. For these reasons, the selected code is a quasi-cyclic high-rate LDPC code that is a modification of a regular (4,32) code, known as C2 (reference [37]).

2. In the Deep Space case, data rates are relatively low, which allows low rate codes to fit in the allocated band even though the bandwidth expansion is greater. Deep Space signals travel much greater distances, requiring extremely good SNR performance. This is accomplished by using codes that have greater redundancy (low rate) and greater complexity (so they may require more iterations to achieve best performance). Since the data rates are lower, the features required for better performance are not a burden on the system. For these reasons, a set of nine LDPC codes belonging to the AR4JA (Accumulate, Repeat-by-4, and Jagged Accumulate) family (references [45] and [46]) have been selected.

The selected code rates are $1/2$, $2/3$, $4/5$, and approximately $7/8$, which are about uniformly spaced by 1 dB on the rate-dependent capacity curve for the binary-input AWGN channel (reference [16]). Near rate $1/2$, a one-percent improvement in bandwidth efficiency costs about 0.02 dB in power efficiency; near rate $7/8$, a one-percent improvement in bandwidth efficiency costs 0.1 dB in power efficiency.

Within the AR4JA family, the selected block lengths are $k=1024$, $k=4096$, and $k=16384$. The three values $k=\{1024,4096,\infty\}$ are about uniformly spaced by 0.6 dB on the sphere-packing bound at $WER=10^{-8}$, and reducing the last value from ∞ to 16384 makes the largest block size practical at a cost of about 0.3 dB. By choosing to keep k constant among family members, rather than n , the spacecraft's command and data handling system can generate data frames without knowledge of the code rate. To simplify implementation, the code rates are exact ratios of small integers, and the choices of k are powers of two. Code C2 has rate 0.87451 and size ($n=8160$, $k=7136$), which is exactly four times that of the (255,223) RS code.

The selected codes are systematic. A low-complexity encoding method is described in reference [41]. The parity check matrices have plenty of structure to facilitate decoder implementation (reference [42]). The AR4JA codes have irregular degree distributions because this improves performance by about 0.5 dB at rate 1/2, compared to a regular (3,6) code (reference [44]). As the code rate increases towards unity, the performance improvement of an irregular degree distribution becomes small (reference [43]).

8.2 APPLICATIONS OF LDPC CODES

When designing a communications link, selection of the error correcting code requires a trade-off of several parameters. Dominant parameters typically include power efficiency, code rate (a high code rate may be required to meet a bandwidth constraint with the available modulations), and the block length (shorter blocks reduce latency on low data-rate links and reduce encoder and decoder complexity). The trade-off between power efficiency and spectral efficiency for several CCSDS codes is shown in figure 8-1. The horizontal axis is the familiar E_b/N_0 , and the vertical axis shows spectral efficiency in Hz-sec/bit, the reciprocal of the potentially more familiar unit of bits/sec/Hz. It may be noted that both axes are logarithmic. Turbo codes of block lengths $k=8920$ and $k=1784$ are shown in green, the ten LDPC codes are shown in red, and the (7,1/2) convolutional and (255,223) RS codes are shown in blue, both alone and concatenated. When these codes are concatenated, performance improves with greater interleaving depth; shown are $I = 1$ and 5 codewords, and the theoretical limit $I = \infty$. Performance is plotted at a BER of 10^{-6} , and only the convolutional (7,1/2) point moves significantly at other error rates.

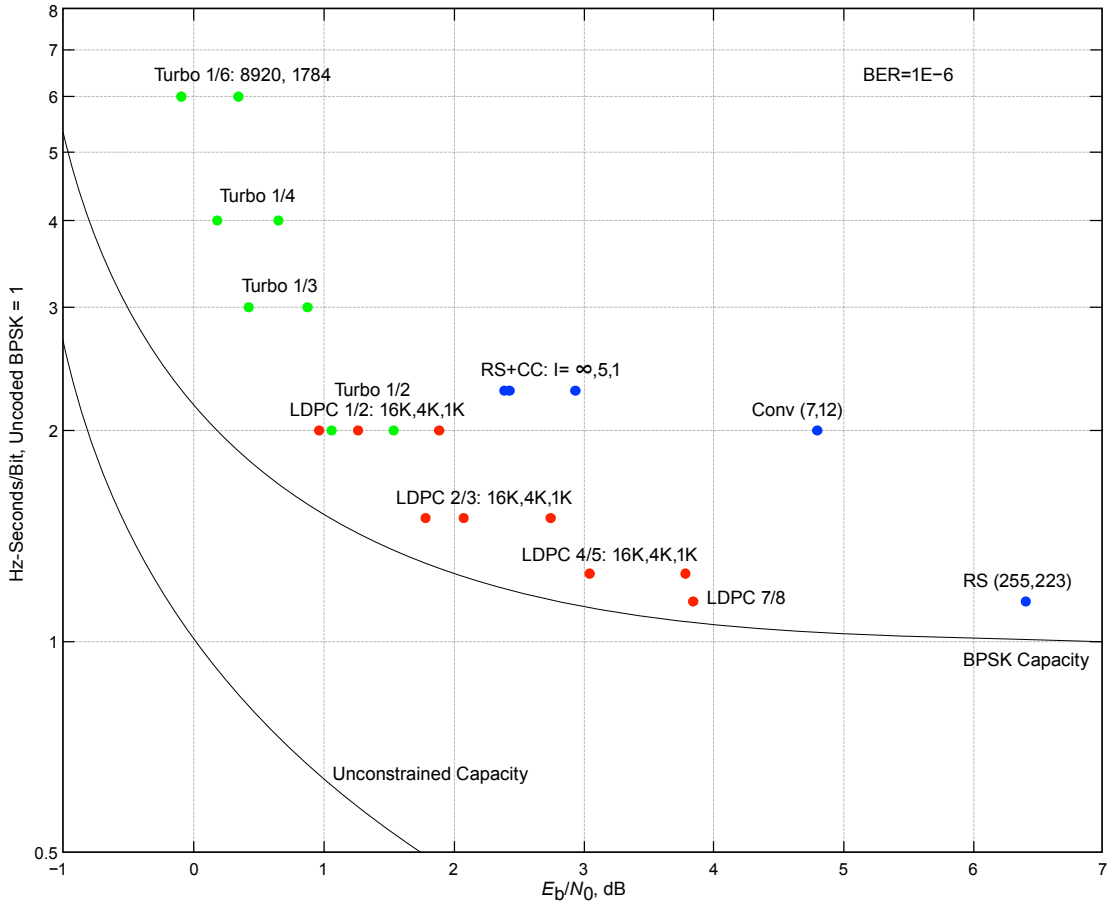

Figure 8-1: Power Efficiency versus Spectral Efficiency for Several CCSDS Codes

When power is extremely constrained, one must choose a code from the left side of the figure and accept the corresponding bandwidth expansion. Conversely, when bandwidth is constrained, one must choose from the points towards the bottom of the figure, at the cost of increased energy per bit. Turbo codes are good choices for power-constrained links, and LDPC codes serve well when bandwidth is constrained, typically for higher data-rate links. It may be noted that the RS and convolutional codes are out-performed in both metrics by LDPC codes.

Also shown in figure 8-1 is the capacity limit on a binary-input AWGN channel, and the unconstrained AWGN channel capacity (Reference [47]). The region between these capacity limits becomes available with the use of higher order modulations, as shown in figure 8-2. To the extent possible with available equipment, the use of a higher order modulation may be a more practical means for saving bandwidth than the use of a code with rate much above 0.8. For the QPSK and 16-APSK modulations, performance results are shown only for the longest block length at each code rate. While 8-PSK data are also omitted for clarity, they can be interpolated from the QPSK and 16-APSK results.

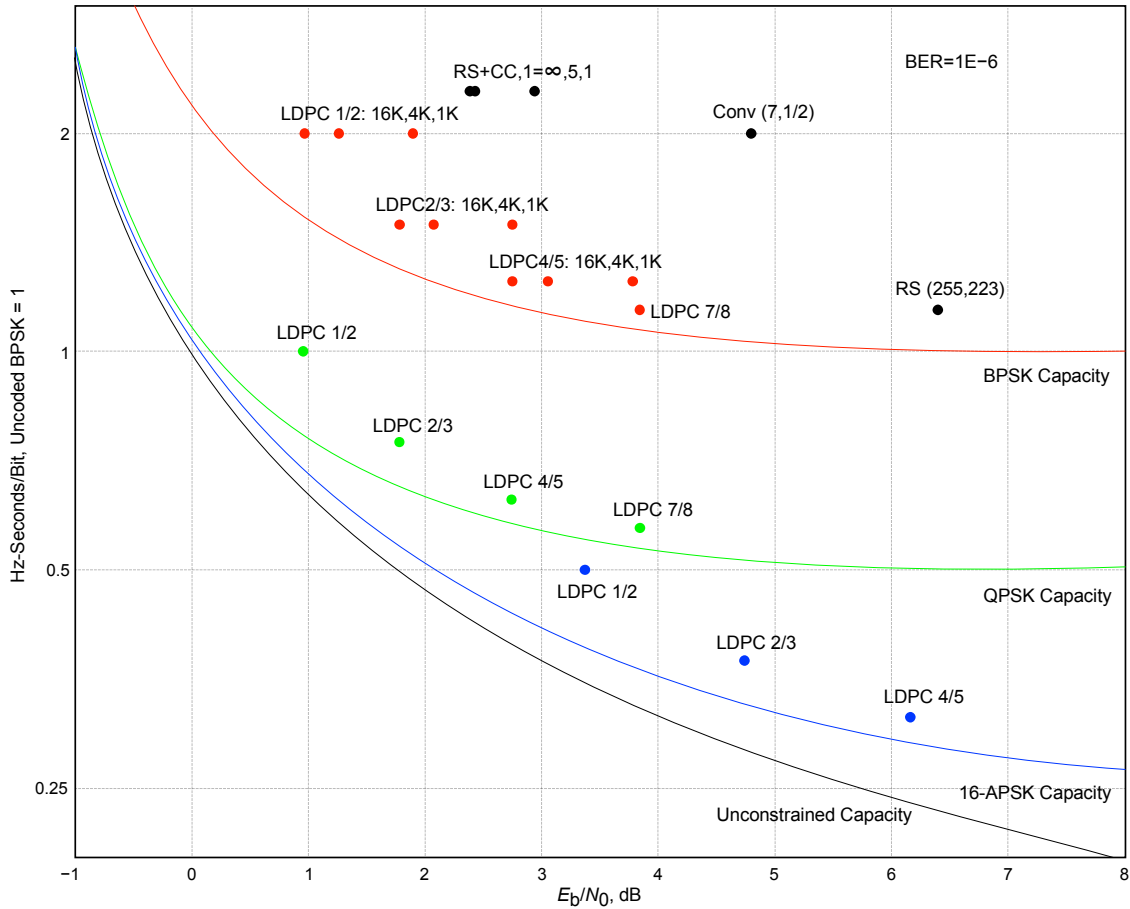

Figure 8-2: Power Efficiency versus Spectral Efficiency for Higher Order Modulations

8.3 PARITY CHECK AND GENERATOR MATRICES FOR THE LDPC CODES

The LDPC codes are quasi-cyclic. Their parity check matrices are defined as a juxtaposition of smaller cyclic submatrices, known as circulants. A circulant is a square matrix of binary entries, in which each row is a one-position right cyclic shift of the previous row. Hence the entire circulant is determined by its first row, and low-weight circulants are used to define parity check matrices with low density.

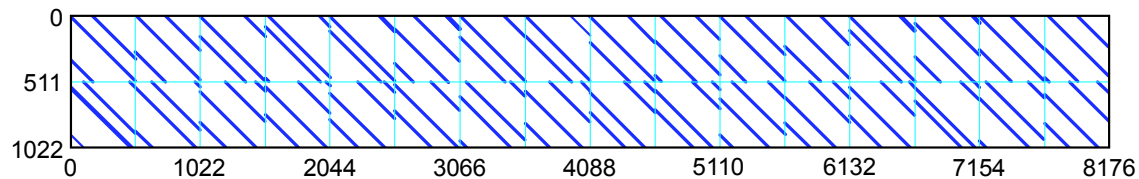

Figure 8-3: Parity Check Matrix for Code C2

Code C2 is constructed from a basic code defined by its 1022×8176 block-circulant parity check matrix H shown in figure 8-3, and figure 6-1 of reference [3]. Each circulant has weight 2, so each column of this parity check matrix has weight 4 and each row has weight

32, thus defining a regular (4,32) LDPC code. This parity check matrix has two linearly dependent rows, so it has rank 1020.

A generator matrix for this code has size 7156×8176 . When the first 7154 positions are made systematic, then the first 7154 rows can be written in the block-circulant form shown in figure 6-2 of reference [3]. The remaining two rows can be chosen as

$$\begin{bmatrix} g_{7155} \\ g_{7156} \end{bmatrix} = \begin{bmatrix} 0^{511 \times 14} & 1^{511} & 0^{511} \\ 0^{511 \times 14} & 0^{511} & 1^{511} \end{bmatrix},$$

where X^n represents the digit X repeated n times. This construction is not sufficient to make the dense circulants $B_{i,j}$ unique because g_{7155} and g_{7156} may be added arbitrarily to each. The circulants were chosen so that their upper right corners are ‘0’, making each of the hexadecimal numbers in table A-1 of reference [3] even. The code is then expurgated by leaving dimensions g_{7155} and g_{7156} unused.

Equivalently, one could expurgate the code defined by H by adding two linearly independent constraints:

$$\begin{bmatrix} h_{1023} \\ h_{1024} \end{bmatrix} = \begin{bmatrix} 0^{511} & 0^{511} & 0^{511} & 0^{511} & 0^{511} & 1^{511} & 1^{511} & 0^{511} & 1^{511} & 1^{511} & 1^{511} & 0^{511} & 0^{511} & 1^{511} & 1^{511} & 0^{511} \\ 0^{511} & 0^{511} & 0^{511} & 0^{511} & 1^{511} & 1^{511} & 0^{511} & 1^{511} & 0^{511} & 1^{511} & 1^{511} & 1^{511} & 1^{511} & 1^{511} & 0^{511} & 1^{511} \end{bmatrix}$$

The block-circulant generator matrix for this code, systematic in the first 7154 positions, is unique and matches that described above.

This expurgated code is shortened by setting the first 18 information bits to ‘zero’ (and not transmitting them), and extended by appending two ‘zeros’. The resulting code, C2, has size ($n=8160, k=7136$). These parameters are multiples of 32 for convenience with 32-bit microprocessors and also match the size of the (255, 233) RS code with an interleave depth of $I=4$.

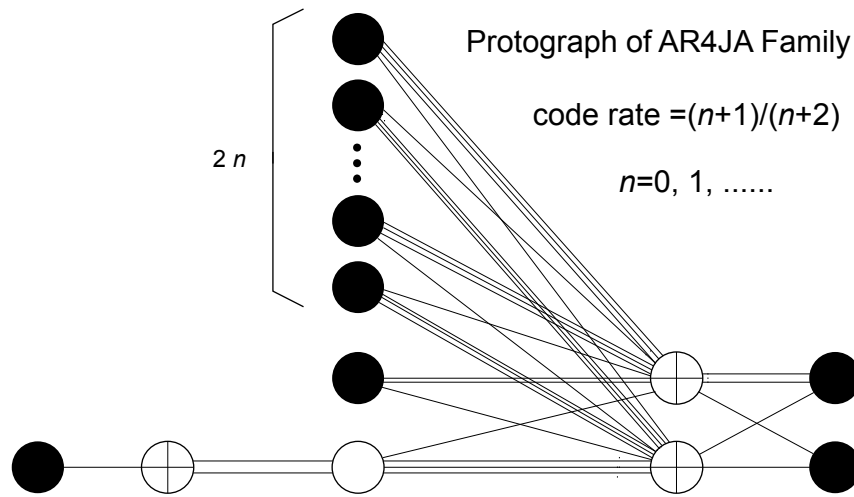

Figure 8-4: Protographs for the AR4JA Code Family

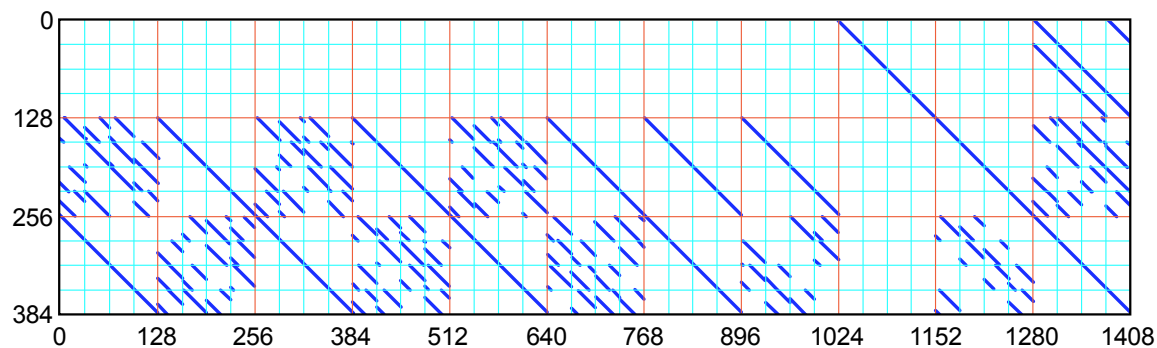

Figure 8-5: Parity Check Matrix for the ($n=1280$, $k=1024$) AR4JA Code

The AR4JA family of codes are built from a protograph shown in figure 8-4, with $n \in \{0,1,3\}$, where solid circles denote transmitted variable nodes, the open circle denotes a punctured variable node, and the circled crosses denote check nodes. These protographs are expanded with circulants, in two stages, to build the parity check matrices. The first circulant expansion by a factor of 4 eliminates the parallel edges in the protograph, and the second expansion by the appropriate power of two creates the final parity check matrices. The circulants were chosen by randomized computer search and heuristics (reference [48]) to reduce the number of ‘trapping sets’; all parity check matrices are full rank. For example, the parity check matrix for the ($n=1280$, $k=1024$) rate 4/5 code is shown in figure 8-5. The final 128 columns correspond to punctured symbols, and this puncturing increases the rate of the code from 8/11 to 4/5. Generator matrices for the AR4JA family, systematic in the first k positions, can be computed using the usual matrix inverse method, though it is computationally burdensome for the larger cases.

8.4 LDPC ENCODERS

The recommended LDPC codes are systematic in their first k symbols, and the following $n-k$ parity symbols may be computed by multiplication by the parity portions of the dense generator matrices. The number of binary operations required is proportional to $k(n-k)$, but because the generator matrices have a block-circulant structure, their descriptive complexity is proportional to $n-k$.

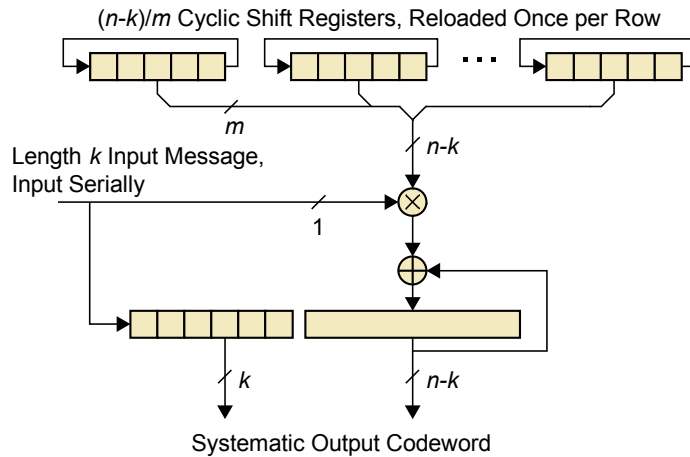

Figure 8-6: One Encoder for Block-Circulant LDPC Codes

One natural implementation is shown in figure 8-6 (reference [49]). First, the $n-k$ digits from the first row of the generator matrix are placed in the top row of the boxes in the figure, with m digits in each of the $(n-k)/m$ cyclic shift registers. The first message bit is multiplied by this vector, and the result is placed in an accumulator. Then the shift registers are cycled one position to construct the second row of the generator matrix; the result is multiplied by the next message bit and added to the accumulator. This is repeated m times to complete the first row of circulants in the generator matrix. Then the first row from the next set of circulants is loaded into the cyclic shift registers, and the process is repeated until all k message bits are encoded. The k message bits, concatenated with the $n-k$ symbols in the accumulator, give the output codeword. This implementation requires $2(n-k)$ memory cells and $k(n-k)$ binary multiply-accumulate operations.

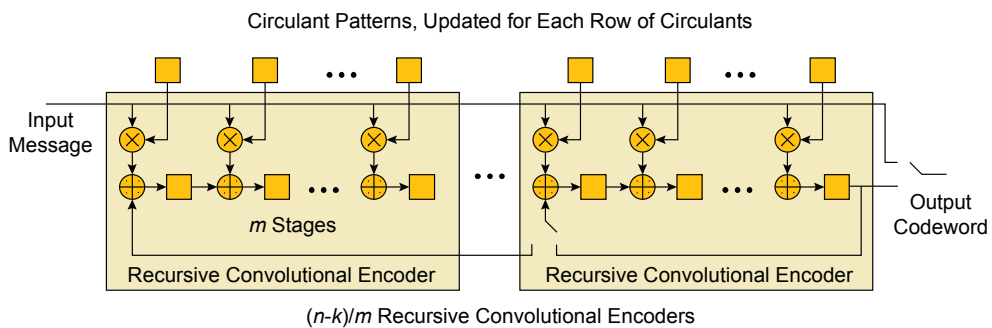

Figure 8-7: Another Encoder for Block-Circulant LDPC Codes

This implementation can be simplified as shown in figure 8-7 (reference [50]). Rather than cyclically shifting the memory cells holding the generator matrix patterns, the cyclic shift operations are performed on the accumulator’s memory cells. With this modification, the upper row of memory cells can be eliminated entirely and replaced with simple combinatorial functions of the index variable that counts rows of circulants.

8.5 LDPC DECODERS

LDPC codes are designed for use with an iterative belief-propagation decoder. Conceptually, there is a ‘variable node’ processing unit assigned to each code symbol (including the punctured symbols for the AR4JA codes), and a ‘check node’ processing unit assigned to each constraint equation in the parity check matrix. Initially, each variable node forms a probability distribution over the symbol alphabet ($\{0,1\}$ for these binary codes) based on the channel observations. A variable node corresponding to a punctured symbol assumes a uniform a-priori distribution over $\{0,1\}$, so it initializes each probability to $1/2$, or a Log Likelihood Ratio (LLR) to 0. These probability distributions are passed to the check nodes in which the variables participate. The check nodes look for consistency among the probability distributions and return a measure of the amount of unreliability to each variable node, thus completing the first decoding iteration. The variable nodes update their probability distributions based on the returned messages, and the process repeats for further iterations. After some number of iterations, decoding is stopped, and the most probable symbol from each variable node is taken as the decoded result.

Different decoders use different functions at the variable and check nodes, and a complete theory of the optimal functions is lacking. It is generally accepted that the best performance is given by the updated equations in log likelihood ratio form as

$$v_i = \lambda_i + \sum_{j \neq i} u_j \text{ and}$$

$$u_j = 2 \tanh^{-1} \left(\prod_{i \neq j} \tanh \frac{v_i}{2} \right),$$

for the variable nodes and check nodes, respectively. In hardware, the second equation is impractical, and a variety of approximations to the transcendental functions are used. To reduce computational complexity, either or both equations are often further approximated. Hardware implementations typically use fixed-point arithmetic and compute log likelihoods with eight bits of precision (for negligible loss), three to five bits (for loss of a couple of tenths of a dB), or just one bit for the simplest ‘bit flipping’ algorithms.

Decoders may use different message-passing schedules between the variable nodes and the check nodes. The most common is the ‘flooding’ schedule in which all variable nodes perform their computations and send their messages, and then all check nodes perform their computations and send replies, and so on. There is ongoing study of different message-passing schedules, and some researchers report considerable reductions in the number of iterations and computation required.

Software decoders must typically perform the computations for each variable node and check node serially. Hardware decoders usually contain several variable node and check node processing units, but not enough for the entire code graph, so the nodes are partitioned into sets that are updated simultaneously. While details depend strongly on the hardware resources available, three techniques for the recommended block-circulant codes deserve

mention. A ‘universal decoder’ contains general-purpose variable node and check node units and performs computations based on a programmed description of the code and update schedule. A ‘protograph decoder’ contains variable and check node units wired together into one (or more) copies of the protograph. It updates all the nodes in a protograph simultaneously and proceeds serially through the copies of the protograph. A ‘SIMD decoder’ uses the Single-Instruction Multiple-Data concept and contains all the copies of one protograph node in hardware. This decoder updates all the copies of one node simultaneously and proceeds sequentially through the other protograph nodes.

Decoders also vary in the number of decoding iterations performed. Conceptually, it is simplest to perform some fixed number of iterations for every codeword, in which the number required is larger for lower code rates, longer block lengths, and lower SNR. The average amount of computation can be dramatically reduced with a stopping rule that halts the decoder when it has converged to a solution. The most common stopping rule uses tentative hard decisions from the variable nodes and halts decoding either when all the constraint equations are satisfied or when some fixed maximum number of iterations is reached. Under typical operating conditions, a very few codewords fail to decode after the maximum number of iterations allowed, and most decode in a small fraction of this maximum. By stopping a hardware decoder early, power can be saved; if the decoder can proceed and decode the next codeword, its average throughput can be increased.

An iterative decoder with a stopping rule takes a variable amount of time to decode a noisy codeword. If this is problematic for either the preceding or following signal processing stages, memory buffers may be inserted before or after the decoder. Buffers large enough to store just a few codewords are sufficient to increase a decoder’s throughput from its worst-case capability to nearly its average capability, and this is typically several times faster. Further details are in reference [52].

8.6 PERFORMANCE OF THE RECOMMENDED LDPC CODES

Performance does not only depend on the code, but also on the decoder for the code. Many design choices must be made when implementing a practical belief-propagation decoder, and one cannot expect independent implementations to perform identically. However, experience shows that, in the ‘waterfall’ region, good implementations perform within 0.1 dB of the curves shown here. The ‘error floor’ region is subject to much greater variability, often changing in error rate by an order of magnitude or more. Consistent design of good decoders in this region remains an open research question.

Performance curves were determined by simulation on a Field Programmable Gate Array (FPGA) at JPL, and the results are shown in figure 8-8 (reference [51]). The dashed curves show FER, and the solid curves show BER. While FER is the more useful metric for packet-based communications systems, BER is more commonly shown for existing codes and is included here for ease of comparison.

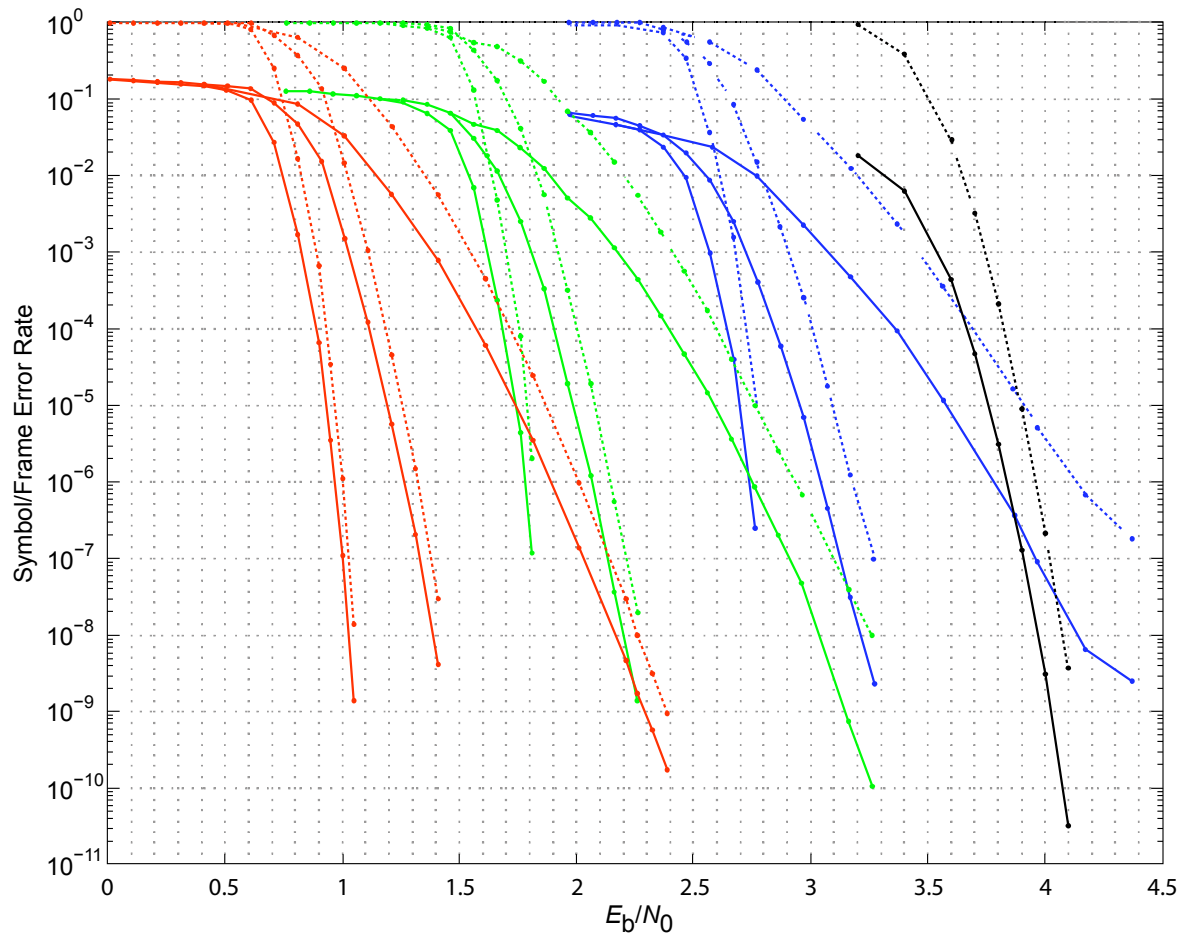

Figure 8-8: Bit Error Rate (Solid) and Frame Error Rate (Dashed) for Nine AR4JA Codes and C2, with Code Rates 1/2 (Red), 2/3 (Green), 4/5 (Blue), and 7/8 (Black); and Block Lengths $k=16384$, 4096, 1024 (Left to Right in Each Group), and 7156 (Code C2)

8.7 IMPROVING PERFORMANCE IN THE ERROR FLOOR REGION

When using common LDPC decoders with standard check node processing, the appearance of an error floor effect may occur for some of the recommended AR4JA LDPC codes.

In particular, the rate 2/3 AR4JA code with $k=1024$ information bits and, in a more marked manner, the rate 4/5 AR4JA code with $k=1024$ information bits may exhibit a slope flattening at a FER on the order of 10^{-6} .

This effect can be compensated by optimizing the LDPC decoding algorithm. In particular, the decoder should (reference [54])

- use a suitably high number of iterations (above 50);

- use a soft-message quantization strategy with suitable resolution (at least 8 bits of quantization);
- use a suitable clipping strategy for soft-messages, particularly for degree-1 variable nodes;
- effectively implement the check node operations, by also controlling the effects of the quantization noise; and
- include a partial hard-limiter of the check node messages.

All these variations improve performance of the LDPC decoder and lower the error floor in the error rate curves.

The reported performance of AR4JA LDPC codes has been obtained with optimized LDPC decoders (reference [54]) and has been assessed, through numerical simulations, down to BER on the order of 10^{-10} and FER on the order of 10^{-8} .

9 IMPORTANT ANCILLARY ASPECTS OF THE CODING SYSTEM

9.1 GENERAL

The preceding four sections have described how one would encode and decode each of the recommended codes and their corresponding performance under ideal circumstances. CCSDS Recommended Standards (references [3] and [2]) also impose certain ancillary conditions on the coding system in order to approach this ideal performance in a practical system. Chief among these ancillary requirements addressed in Recommended Standards (references [3] or [2]) are the following:

- a) the coded output of all codes (or of uncoded data) must be sufficiently random to ensure proper receiver operation;
- b) there must be a method for synchronizing the received data with the codeword or codeblock boundaries;
- c) there must be a way to certify the validity of decoded data with a high amount of certainty.

There are a couple of additional ancillary issues associated with the recommended codes:

- a) some of the recommended codes are ‘transparent’ to inversion of the received data, and some are not;
- b) 1:1 remappings of the information or coded bits may be permitted but may affect performance.

9.2 RANDOMIZATION OF THE CODED OUTPUT

9.2.1 GENERAL

Randomization of the data stream provides some useful functions. It aids in achieving

- signal acquisition;
- bit synchronization;
- proper decoding;
- ambiguity resolution for convolutional decoder operation;
- absence of incorrect frame synchronization for RS and LDPC codes; and
- reduction of spurious frequencies and compliance with power density masks.

Receiver acquisition performance is often impaired by short periodic data patterns. Randomizing the data avoids this.

In order to acquire and maintain symbol synchronization with the coded symbol boundaries, a bit synchronizer requires a sufficient symbol transition density. The recommended non-punctured (7,1/2) convolutional code contains an inverter on one of its outputs, which assures a sufficient symbol transition density when this code is used with BPSK modulation. Although this inverter may be sufficient for proper operation of the bit synchronizer, it does not guarantee that the receiver and decoder will work correctly. In contrast, when the recommended RS code is used alone, or the data is uncoded, there may be no symbol transitions, for example, if all-‘zero’ data is sent.

While alternate symbol inversions solve the symbol synchronization problem for the case of convolutional codes with BPSK modulation, it is desirable to offer a universal solution for all three issues and any of the recommended codes. The pseudo-randomizer defined in section 7 of reference [3] gives such a solution. This randomizer adds (modulo-2) a pseudo-random sequence to the coded symbols.

9.2.2 RANDOMIZATION AND DE-RANDOMIZATION

A PN data sequence used for randomization is commonly written in terms of binary values, ‘1’ and ‘0’. It can also be written using the symbols ‘1’ and ‘-1’, or other symbols. Randomization of data (different from scrambling) is done by applying the first bit of the randomization pattern to the first bit of the data, applying the second bit of the randomization pattern to the second bit of the data, and so on. Generally, when the bit in the randomization pattern is a ‘0’, the data is left unchanged, and when the bit of the randomization pattern is a ‘1’, the data value is inverted.

In this case ‘inverted’ means that, if the original data bit is a ‘0’, it is changed to a ‘1’, and if it is originally a ‘1’, it is changed to a ‘0’. This is the same as applying an exclusive-OR to the bit pairs. At the receiver, when a soft decision representation is used for the data, inversion is still a valid concept, but the representation of the data must be taken into account. Exclusive-OR no longer applies.

For example, with 3-bit soft decision, data and its inverse are represented as:

	Binary	Binary	Sign-Mag	Sign-Mag	2’s comp	2’s comp
	normal	inverse	normal	inverse	normal	inverse
Strong 1	111	000	011	111	011	100
	110	001	010	110	010	101
	101	010	001	101	001	110
Weak 1	100	011	000	100	000	111
Weak 0	011	100	100	000	111	000
	010	101	101	001	110	001
	001	110	110	010	101	010
Strong 0	000	111	111	011	100	011

The intent is to show that a strong ‘0’ or ‘1’ becomes a strong ‘1’ or ‘0’, and a weak ‘0’ or ‘1’ becomes a weak ‘1’ or ‘0’. In the case of binary and 2’s complement, the 3-bit representation happens to be the complement of the original value, but that is not a general case as seen in the case of the Sign-Magnitude.

9.2.3 DESCRIPTION OF THE RECOMMENDED PSEUDO-RANDOMIZER

The method for ensuring sufficient transitions is to use, for randomization, a standard pseudo-random sequence. If the Pseudo-Randomizer is used, on the sending end, it is applied to the codeblock, codeword, or Transfer Frame after Turbo encoding or RS encoding (if either is used), but before convolutional encoding (if used). On the receiving end, it is applied to derandomize the data after convolutional decoding (if used) and codeblock or codeword synchronization, but before RS decoding or Turbo decoding (if either is used).

The configuration at the sending end is shown in figure 9-1.

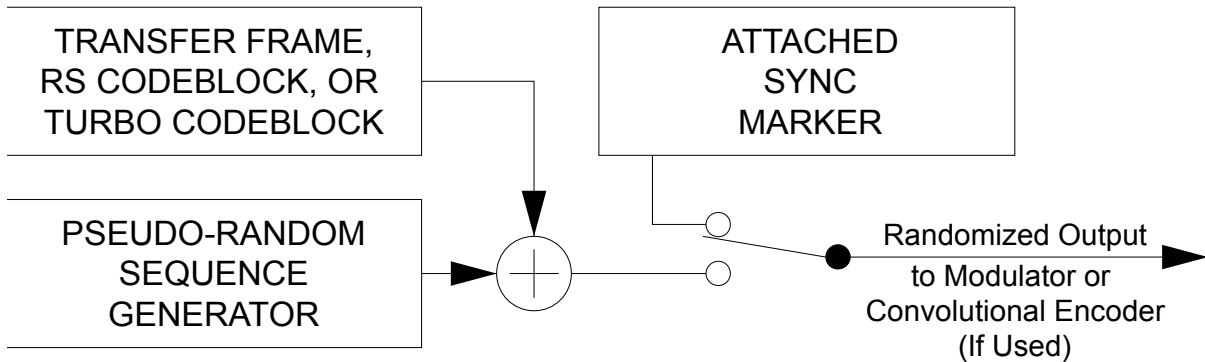

Figure 9-1: Block Diagram of the Recommended Pseudo-Randomizer

The Attached Sync Marker (ASM) is already optimally configured for synchronization purposes and is therefore used for synchronizing the Pseudo-Randomizer. The pseudo-random sequence is applied starting with the first bit of the codeblock, codeword, or Transfer Frame. On the sending end, the codeblock, codeword, or Transfer Frame is randomized by inverting the first bit of the codeblock, codeword, or Transfer Frame based on the value of the first bit of the pseudo-random sequence, followed by the second bit of the codeblock, codeword, or Transfer Frame based on the value of the second bit of the pseudo-random sequence, and so on. On the receiving end, the original codeblock, codeword, or Transfer Frame is reconstructed using the same pseudo-random sequence. After locating the ASM in the received data stream, the pseudo-random sequence is used to invert the data bits immediately following the ASM. The pseudo-random sequence is applied by inverting the first bit following the ASM based on the value of the first bit of the pseudo-random sequence, followed by the second bit of the data stream based on the value of the second bit of the pseudo-random sequence, and so on.

The pseudo-random sequence used in the CCSDS standard is generated by using the following polynomial:

$$h(x) = x^8 + x^7 + x^5 + x^3 + 1$$

This sequence begins at the first bit of the codeblock, codeword, or Transfer Frame and repeats after 255 bits, continuing repeatedly until the end of the codeblock, codeword, or Transfer Frame. The sequence generator is initialized to the all-‘ones’ state at the start of each codeblock, codeword, or Transfer Frame.

The first 40 bits of the pseudo-random sequence from the generator are shown below; the leftmost bit is the first bit of the sequence to be used for inverting the first bit of the codeblock, codeword, or Transfer Frame; the second bit of the sequence is used for inverting the second bit of the codeblock, codeword, or Transfer Frame, and so on.

1111 1111 0100 1000 0000 1110 1100 0000 1001 1010 ...

9.2.4 HIGH DATA RATE RANDOMIZATION

As observed in reference [62], spurious problems may arise when the CCSDS standard randomizer is used at high data-rates.

At the Earth’s surface, the Power Flux Density (PFD) produced by spacecraft emissions must not exceed pre-fixed values, fixed by ITU (reference [63]) and ECSS (reference [64]). When designing a space mission, the satisfaction of these levels (with some extra margin ϵ) is conjectured on the basis of an ‘ideal’ continuous PSD, under the hypothesis of random binary transmitted sequences. When payload Transfer Frames are transmitted, the CCSDS LFSR is sufficient to provide good randomness: the received PSD is indeed nearly ideal and compliant with ITU Recommendations.

Only Idle Data (OID) Frames can be inserted within transmission to preserve frame continuity when no payload Transfer Frames are ready to be transmitted. The data fields of OID frames are typically filled by ‘zero’ bits. After randomization, the random properties of the binary transmitted sequences are dominated by the period N of the CCSDS LFSR. This LFSR is rather short ($L = 8$ cells), so the corresponding period is quite small ($N = 255$). As a consequence, the PSD may show spurious much-higher-than-the-ideal curves, corresponding to a received PFD not satisfying the ITU Recommendations.

For this reason, depending on the mission requirements, the use of a longer LFSR and also of more complicated solutions may be needed for randomization of high rate data (references [65] and [66]).

This behavior basically depends on three parameters: the randomizer LFSR period N ; the codeblock, codeword, or Transfer Frame length F ; and the transmitted bit rate R_b .

If $N < F$, the randomized sequence shows an ‘inner periodicity’. In particular, taking into account that N is odd and focusing on 4-PSK modulation, that selects a couple of bits per

each symbol, the length of this periodicity is $2N = 510$ bits for the standard CCSDS randomizer, that is, $2N/R_b$ seconds. This determines the appearance of significant spurious frequencies in the PSD. The expected spurious separation is

$$\Delta = \frac{R_b}{2N} \text{ Hz.}$$

Based on the value of Δ , the following condition can be verified: $\Delta \leq \delta$, where δ is the resolution bandwidth imposed by the regulations ($\delta = 4$ kHz for the ITU regulation, reference [63]). It can be shown that this condition is sufficient for being compliant with the regulations, up to a margin of 3 dB, when only LFSR are transmitted (reference [65]). In the case of actual Transfer Frames, this is, in general, no longer true, but the same condition can be assumed as necessary. Then, the actual PSD shall be evaluated, together with the corresponding Maximum Spurious Excess (MSE), defined as the maximum difference between the value of simulated PSD in a δ Hz bin and 0 dB (the value of PSD in the reference bin for the ideal curve).

Since the CCSDS LFSR has a small period ($N = 255$ bits), in order to verify the necessary condition on the spurious separations, the maximum bit rate must be upper limited:

$$\Delta = (R_b/(2N)) < 4 \text{ kHz} \rightarrow R_b < 8N \text{ kb/s} = 2.04 \text{ Mb/s}$$

In the case of values of N , F , and R_b , if the regulations are not satisfied, a first solution consists in increasing N . In reference [62], use of a larger LFSR (with $L = 15$ memory cells) is proposed, generated by using the polynomial

$$h(x) = x^{15} + x^{14} + 1,$$

which guarantees to produce a binary sequence with period $N = 2^L - 1 = 32767$ bits. Since N is much larger than before, the maximum bit rate satisfying the spurious separation constraint becomes very large:

$$\Delta = (R_b/(2N)) < 4 \text{ kHz} \rightarrow R_b < (8N) \text{ kb/s} = 262.136 \text{ Mb/s}$$

However, this holds if and only if the codeblock, codeword, or Transfer Frame length F is longer than the LFSR period N (i.e., it contains more than one LFSR period). Indeed, if F is shorter than N , the situation changes. In this case, since the LFSR is restarted at the beginning of each frame, all the Channel Symbol frames are equal and show a periodicity equal to the Channel Symbol frame length (C), that is, the codeblock, codeword, or Transfer Frame length F plus the ASM length. As a consequence, in this case, the spurious separation is not imposed by the LFSR period N , but by the Channel Symbol frame length C . Taking into account that C is generally even, the transmitted waveform shows a periodicity of length C , corresponding to C/R_b seconds. For the considered case of 4-PSK modulation, in particular, this yields the following conditions on the spurious separation (which is sufficient but not necessary for compliance with the masks):

$$\Delta = (R_b/(2N)) < 4 \text{ kHz} \quad \text{or} \quad \Delta = (R_b/C) < 4 \text{ kHz.}$$

If this condition is not satisfied, compliance with the regulations on the PSD may not be ensured. A possible solution to this problem is to remove the constraint that OID Frames are filled by all-‘zero’ bit patterns. This can be done as follows (reference [65]):

- a) testing, within the Code & Sync layer, the TF first header pointer;
- b) if it is equal to ‘1111111110’, filling the TF data field with pseudo-noise bits before entering the encoder.

In principle, the pseudo-noise bits should be generated by an ad-hoc long asynchronous LFSR, that is, an LFSR that is not restarted at the beginning of each frame but runs independently (as an example, a 32-cell LFSR). This way, the transmission of OID frames would become not different from the transmission of payload frames, and the autocorrelation function would not show any periodicity, thus becoming certainly compliant to the spurious separation constraint, nominally without margin.

OID frames may sometimes be used for BER evaluation (by exploiting the fact that their data field is known). In this case it would not be possible to fill the OID data field by a completely asynchronous long LFSR. It could be possible to restart the long asynchronous LFSR every X frames, with X sufficiently high, without significant performance losses.

According to this proposal, the modified OID TFs are then scrambled by the randomizer as are all the other Transfer Frames (possibly by using the 15-cell randomizer described above).

Moreover, since the change is performed within the Code & Sync layer, the Data Link layer can continue to use the common practice of filling OID data field by all ‘zero’ bits. At the receiver side, the OID TFs are individuated by testing the TF first header pointer and eliminated, so the data field change is inessential.

9.2.5 USAGE CIRCUMSTANCES FOR THE RECOMMENDED PSEUDO-RANDOMIZER

The Recommended Standard (reference [3]) does not always require the use of the universal solution provided by the pseudo-randomizer. As has been seen, its use would be superfluous in the case of convolutional coding with alternate symbol inversions and BPSK modulation. Less conclusively, Turbo codes might inherently provide sufficient randomness because of their recursive convolutional encoding of non-‘zero’ data headers at the beginning of each data block. I&T project personnel may prefer un-randomized data so that during testing, they can read the binary data that they are familiar with. One answer is to implement the recommended pseudo-randomizer but make it switchable so that during early testing it can be turned off.

While the recommended pseudo-randomizer is not strictly required, the system engineer must take all necessary steps to ensure that the coded symbols have sufficient transition density. Several projects have encountered unexpected problems with their telemetry links because this pseudo-randomizer was not used and sufficient randomness was not ensured by other means and properly verified. These problems are traced to a lack of randomization at the data or modulation symbol level. In many communication system designs, the receiver,

bit/symbol synchronizer and convolutional decoder all have specific requirements that are met by using randomized data. Details may change depending on modulation type, data format (NRZ-L vs. Bi Phase L) and signal to noise ratio. If the implementer can adequately prove that a symbol stream with the proper randomness and balance of 1s and 0s can be achieved without the use of the recommended pseudo-randomizer to 1) ensure a high probability of receiver acquisition and lock in the presence of data, 2) eliminate DC offset problems in PM systems, 3) ensure sufficient bit transition density to maintain bit (or symbol) synchronization, and 4) handle special coding implementations (i.e., data that is multiplexed into multiple convolutional encoders), then the recommended Pseudo-Randomizer may be omitted.

The presence or absence of Pseudo-Randomization is fixed for a physical channel and is managed by the ground system (i.e., its presence or absence is not signaled in the telemetry but must be known a priori).

9.3 FRAME SYNCHRONIZATION

9.3.1 GENERAL

Each of the recommended codes requires a method for aligning the sequence of received code symbols with the boundaries of its codewords or codeblocks (or code symbol periods, in the case of convolutional codes). Otherwise, the decoder would fail because it would be applying the correct decoding algorithm to an incorrect subset of received code symbols. The synchronization requirements are different for each of the recommended codes, as described in the next four subsections.

9.3.2 SYNCHRONIZATION FOR CONVOLUTIONAL CODES

For a rate $1/n$ convolutional code, the encoding rule, and hence the decoding rule, are ‘time-invariant’ in that the same rule is applied at each bit time. Thus even though the convolutional codeword is indefinitely long, the only requirement for proper synchronization is to correctly establish the identity of the starting symbol of any group of n symbols produced in one bit time. This procedure is commonly called ‘node synchronization’. For the recommended rate-1/2 non-punctured convolutional code, as well as the entire series of recommended punctured convolutional codes derived from the rate-1/2 code, node synchronization is a relatively simple matter of distinguishing between two possible ‘phases’ of the received symbol stream. This can be accomplished with or without the aid of frame synchronization markers in the data. For example, the Viterbi decoder may determine the correct phase by monitoring the rate of growth of its own internal metrics. Some useful techniques for node synchronization are described in reference [13]. Alternatively, for the recommended rate-1/2 convolutional code, node synchronization and frame synchronization can be established simultaneously by locating the (52-symbol invariant part of the) convolutionally encoded synchronization marker within the received symbol stream.

9.3.3 SYNCHRONIZATION FOR REED-SOLOMON CODES

An RS decoder will only decode properly if the starting symbol of each codeword is identified; that is, the decoder requires accurate codeword synchronization. If interleaving is used, further resolution is necessary to determine the starting symbol of each codeblock (interleaved set of I codewords), or else the de-interleaver will fail to work properly.

The recommended method for synchronizing the codeblock is to look for an ASM of 32 bits. This procedure is commonly called ‘frame synchronization’ because, in the absence of RS coding, the same 32-bit synchronization marker is attached directly to the Transfer Frame and is used to locate the start of the frame. When RS coding is used, the 32-bit marker is attached to the beginning of the RS codeblock and is used in the same way to identify the starting symbol of a codeblock. In this case, the synchronization procedure is properly called ‘codeblock synchronization’, but the term ‘frame synchronization’ is often used indiscriminately to refer to both cases.

It is important to note that the codeblock synchronization marker is not encoded by the RS encoder. Thus even though the same 32-bit marker is attached to the same block of information bits, whether they occur in an uncoded Transfer Frame or as the data bits in a systematic RS codeblock, the RS coding cannot be considered a totally separate layer that follows the attachment of the marker to the Transfer Frame. If the coding layer should receive a Transfer Frame with frame synchronization marker already attached, it must detach the marker, encode the Transfer Frame only, and reattach the marker to the encoded codeblock.

9.3.4 SYNCHRONIZATION FOR CONCATENATED CODES

Synchronization for concatenated codes requires finding proper alignment with the boundaries of both constituent codes. The Recommended Standard (reference [3]) requires that the same 32-bit synchronization marker be attached to the recommended RS code, regardless of whether it is concatenated with an inner convolutional code. At the receiving end, the two levels of synchronization can be established by first node-synchronizing the inner convolutional code and then locating the 32-bit synchronization marker after convolutionally decoding. Alternatively, when the inner code is the recommended rate-1/2 convolutional code, node synchronization and frame synchronization can be established simultaneously by locating the (52-symbol invariant part of the) convolutionally encoded synchronization marker within the received symbol stream.

9.3.5 SYNCHRONIZATION FOR TURBO CODES

Codeword synchronization is necessary for proper decoding of Turbo codewords. Synchronization of the Turbo codewords is achieved by using an attached sync marker. The code symbols that compose the sync marker for the Turbo code are attached directly to the encoder output without being encoded. Thus the transmitted sync marker pattern remains static for each codeword.

Synchronization is acquired on the receiving end by recognizing the specific bit pattern of the sync marker in the raw (undecoded) telemetry channel data stream. Synchronization is then confirmed by making further checks. Frame synchronizers should be set to expect a marker at a recurrence interval equal to the length of the sync marker plus that of the Turbo codeblock.

A generic block diagram for generating a Turbo codeblock with an attached sync marker was already shown in figure 7-2. A diagram of the resulting codeword with the attached marker is shown in figure 9-2. It should be noted that the lengths of the Turbo codeword and the sync marker are both inversely proportional to the nominal code rate r . This yields roughly equivalent synchronization performance independent of code rate.

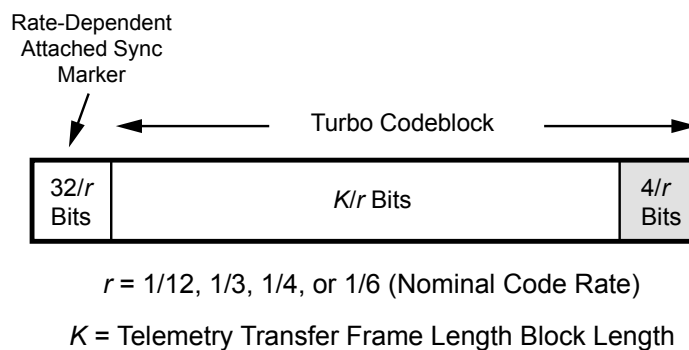

Figure 9-2: Turbo Codeword with Attached Sync Marker

It should be noted that frame sync for the recommended RS/convolutional concatenated code can be acquired using a sync marker defined in the information bit domain rather than the encoded symbol domain, and detected after Viterbi decoding. This method relies on the fact that frame sync is not required for successful operation of the Viterbi decoder but is necessary for decoding the RS code. The Viterbi decoder is capable of finding its own ‘node sync’ with or without the aid of known sync markers in the data stream. The RS decoder has no effective method (other than trial and error) for determining frame sync on its own, and so it must be presented with externally synchronized codeblocks. It is irrelevant to the performance of the RS decoder whether this synchronization is determined from the channel symbols or from Viterbi decoded bits.

In a similar way, the Turbo decoder relies on being handed externally synchronized codewords, but a bit-domain approach does not work effectively for Turbo decoders because each constituent convolutional decoder is too weak by itself to detect a reasonable-size marker reliably, and because the powerful combined Turbo decoding operation needs to know the codeword boundaries before it can iterate between permuted and unpermuted data domains. Therefore Turbo code applications need to use channel-symbol-domain frame sync methods as specified in the Recommended Standard (reference [3]).

It should be noted that, for equivalent performance, channel-symbol-domain frame synchronization requires longer sync markers and faster processing (at the channel symbol rate rather than the Viterbi decoded bit rate).

9.3.6 SYNCHRONIZATION FOR LDPC CODES

Codeword synchronization is required for LDPC codes in very much the same way as it is for Turbo codes. As with Turbo codes, the code symbols comprising the sync marker for the LDPC code are attached directly to the encoder output without being encoded. Thus the transmitted sync marker pattern remains static for each codeword. Synchronization is acquired on the receiving end by recognizing the specific bit pattern of the sync marker in the raw (undecoded) telemetry channel data stream. Frame synchronizers should be set to expect a marker at a recurrence interval equal to the length of the sync marker plus that of the LDPC codeword.

For the nine AR4JA codes, a 64-symbol marker is used, and this is the same marker specified for the rate-1/2 Turbo codes. Because the rate-1/2 LDPC codes and the rate-1/2 Turbo codes operate at similar values of E_s/N_0 , the frame synchronization task is about equally difficult. The rate-2/3 and rate-4/5 LDPC codes operate at higher values of E_s/N_0 , making the frame synchronization task easier.

For code C2, a 32-symbol marker is used, and this is the same marker specified for the RS codes. Because code C2 operates at lower SNR than the (255,223) RS code, frame synchronization is more difficult. However, E_s/N_0 for code C2 is enough greater than that of the rate-1/2 LDPC codes and Turbo codes that synchronization based on its 32-symbol marker remains the easier problem.

9.3.7 IMPLEMENTATION OF FRAME SYNCHRONIZERS

A frame synchronizer may attempt to match just a few, or a great many, received symbols to the known repeating ASM pattern in its search for synchronization. The probability of erroneous synchronization can be made smaller by using more received symbols, but this comes at a cost in latency and in the speed of recovery after an erroneous symbol insertion or deletion in the stream. The optimal frame-synchronization algorithm depends on the relative significance of these factors. A short synchronizer ‘inspection window’ will be necessary if the system has a low latency requirement, and is also the best choice if symbol insertions or deletions are relatively likely. Conversely, if the receiver’s tracking loops virtually never slip, and latency is not a concern, then the frame synchronizer’s error rate can be made arbitrarily small by investigating a sufficiently large number of markers. A third factor in selecting a frame synchronizer is algorithm complexity. Generally, the complexity of the frame synchronizer is dwarfed by that of the decoder for the error-correcting code, so this is not a dominant consideration.

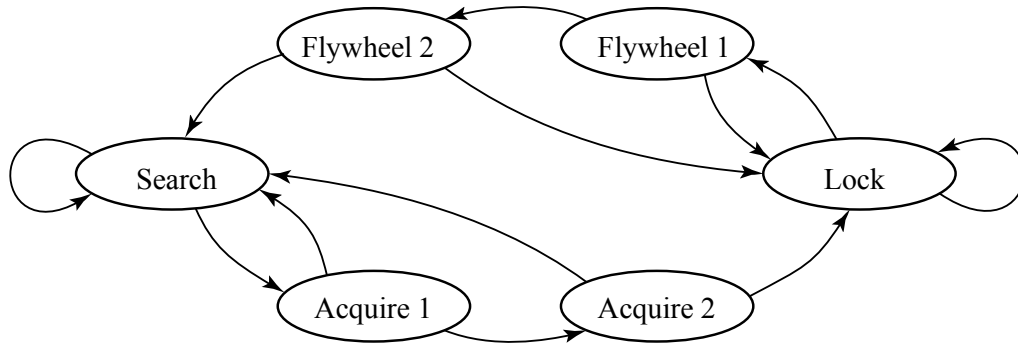

Figure 9-3: A State-Diagram Based Frame Synchronizer

Frame synchronization is an old problem, and standard approaches have long been established. One common solution is based on a state diagram such as the one shown in figure 9-3. A test is performed in each state, and a successful result moves the synchronizer towards the lock state; an unsuccessful result moves it towards the search state. In the search state, a high complexity search for an ASM is performed. When a tentative match is made, verification of some number of subsequent ASMs is necessary in acquisition states before reaching the lock state. Once locked, some number of consecutive ASMs may be missed in flywheel states before a loss of lock is declared and the synchronizer returns to the search state. Typically, all but the search state have very low computational complexity, requiring only the confirmation of an ASM in the anticipated location. If one uses a threshold test based on the soft symbols, the symbol amplitudes must be accounted for properly in the threshold to avoid false confirmations. When improperly handled, these synchronizers may ‘false lock’ at high signal amplitudes. A state machine algorithm is a good choice if the search operation does not need to operate at the full data rate, or if the searching logic can be reused when not in the search state (as with a general-purpose microprocessor implementation). One drawback is that if a symbol slip occurs, several frames will be lost while the synchronizer drops lock and reacquires.

A simple analysis of the behavior of the frame synchronizer while in the search state is carried out in reference [68]. The search state is itself modeled as a state diagram with L states S_0, \dots, S_{L-1} , one for each candidate ASM position. Out of the L states, S_0 corresponds to the true ASM position, and the others to false positions. The probability of recognizing the ASM, given that the current state is S_0 , is denoted by P_{AT} (‘accepting true’). When it is in S_0 , the synchronizer leaves the search state (with success) with probability P_{AT} , while it remains in the search state, moving to S_1 , with probability $1-P_{AT}$. Similarly, the probability of recognizing the ASM, given that the current state is one of the $L-1$ states S_1, \dots, S_{L-1} , corresponding to false ASM positions, is denoted by P_{AF} (‘accepting false’). When in S_i , $i \in \{1, \dots, L-1\}$, the probability of leaving the search state (with an erroneous ASM detection) is P_{AF} and the probability to remain in the search state, moving to $S_{(i+1) \bmod L}$, is $1-P_{AF}$. It is easy to show that the overall probability that the synchronizer leaves the search state accepting a false ASM position is given by

$$P_F = 1 - \frac{(1 - P_{AF})^{L-1} P_{AT}}{1 - (1 - P_{AF})^{L-1} (1 - P_{AT})},$$

where the expressions of P_{AF} and P_{AT} for the case of hard-decision symbols may be calculated, for instance, as explained in reference [68]. For example, considering the rate-7/8 (8160,7136) LDPC code (C2 code) with an ASM of length 32 (so $L = 8192$) over the AWGN channel and BPSK modulation, letting E be the energy per transmitted symbol and N_0 the one-sided power spectral density, and assuming $E/N_0 = 3.4$ dB and no soft information is available at the receiver, the previous formula yields $P_F = 3.4 \cdot 10^{-6}$.

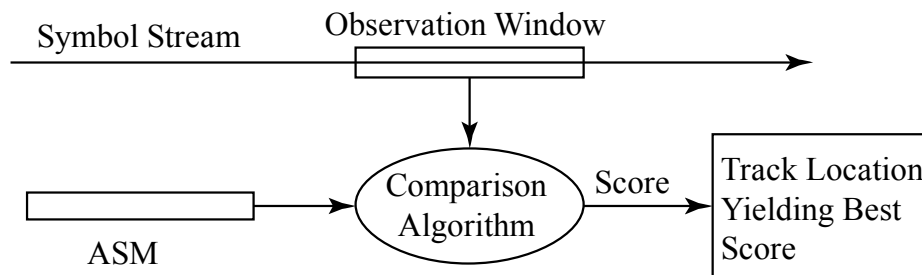

Figure 9-4: An Argmax Frame Synchronizer

A second class of frame synchronizers are argmax algorithms, as sketched in figure 9-4. Such a synchronizer perpetually searches for a marker, and once per frame interval, it announces the location of the best match observed. There are proofs of optimality for some of these algorithms. They do not have locked and unlocked states, so a little additional logic may be necessary to provide a similar status indicator. Let the ASM have the symbol sequence $\{s_1, s_2, \dots, s_M\}$ of length M , with each $s_i \in \{+1, -1\}$, and a codeword have length N , so the data stream is composed of frames of length $F = M + N$. At each offset μ between 0 and $F-1$, the score (or metric) is computed as

$$S_\mu = \sum_{i=1}^M f(s_i, y_{i+\mu}),$$

where the received noisy symbols are denoted by y_i , and $f(s_i, y_{i+\mu})$ is the matching function. The ASM is declared to be at the location with the best score:

$$m = \arg \max_{0 \leq \mu \leq F-1} S_\mu.$$

The *hard correlator*, employed when hard-decision symbols y_i are available at the frame synchronizer, uses the matching function

$$f(s, y) = s \cdot \text{sign}(y).$$

This is the optimal algorithm for synchronization if one must use hard decisions and a single ASM. On the other hand, when soft symbols y_i are available, several metrics may be adopted. The *soft correlator* uses the matching function

$$f(s, y) = s \cdot y$$

and simply sums together the symbol-by-symbol products. It requires a good deal of addition, so when complexity is particularly constrained, the *hard correlator* is often used. James Massey proved in reference [53] that the optimal metric for argmax-based frame synchronization is not the soft correlation, but instead uses the matching function

$$f(s, y) = sy - \frac{N_0}{2\sqrt{E}} \log \cosh\left(\frac{2y\sqrt{E}}{N_0}\right),$$

where E is the symbol amplitude and N_0 is the one-sided noise spectral density. Hence, E/N_0 is the symbol SNR, and \sqrt{E}/N_0 is the *combining ratio*. The transcendental functions are inconvenient in implementation, so Massey also showed that a good approximation is

$$f(s, y) = \begin{cases} 0 & \text{if sign}(y) = s \\ -|y| & \text{otherwise} \end{cases}.$$

That is, only noisy symbols with the wrong sign are counted, and the magnitude of the soft symbol is its penalty. While the exact Massey algorithm requires an estimate of the combining ratio, this approximate Massey algorithm does not. For each of these algorithms, performance can be improved by matching two (or more) consecutive markers, achieving what would be possible with a single marker of twice (or several times) the length.

The performance of the argmax-based frame synchronizer can be evaluated in a very simple way using the tight upper bound developed in reference [67]. Accordingly, the probability of false synchronization of the argmax-based synchronizer, assuming AWGN and $s_i \in \{-1, +1\}$, may be approximated very accurately by the analytical formula

$$P_{FS}(E/N_0) \approx (F-1)P_{sep}(E/N_0),$$

where $P_{sep}(E/N_0)$, called the pairwise synchronization error probability, depends on signal-to-noise ratio E/N_0 , on the ASM length M , and on the adopted metric (e.g., Massey exact, Massey approximated, soft correlation, hard correlation) but not on the frame length F . For a given metric and ASM word length, the values of this probability as a function of E/N_0 may be easily obtained by numerical integration as detailed in reference [67]. Through the above formula for P_{FS} , it is also easy to recognize that the probability of false synchronization of the argmax-based synchronizer is affected by an error floor for large enough E/N_0 , as follows:

$$P_{FS}(\infty) = \frac{(F-1)}{2^{M+1}}.$$

For example, in the case of the C2 LDPC code ($N=8160$) and ASM length $M=32$, an argmax-based frame synchronizer employing the optimum Massey metric would be characterized by an error floor at $P_{FS}(\infty) \approx 10^{-6}$.

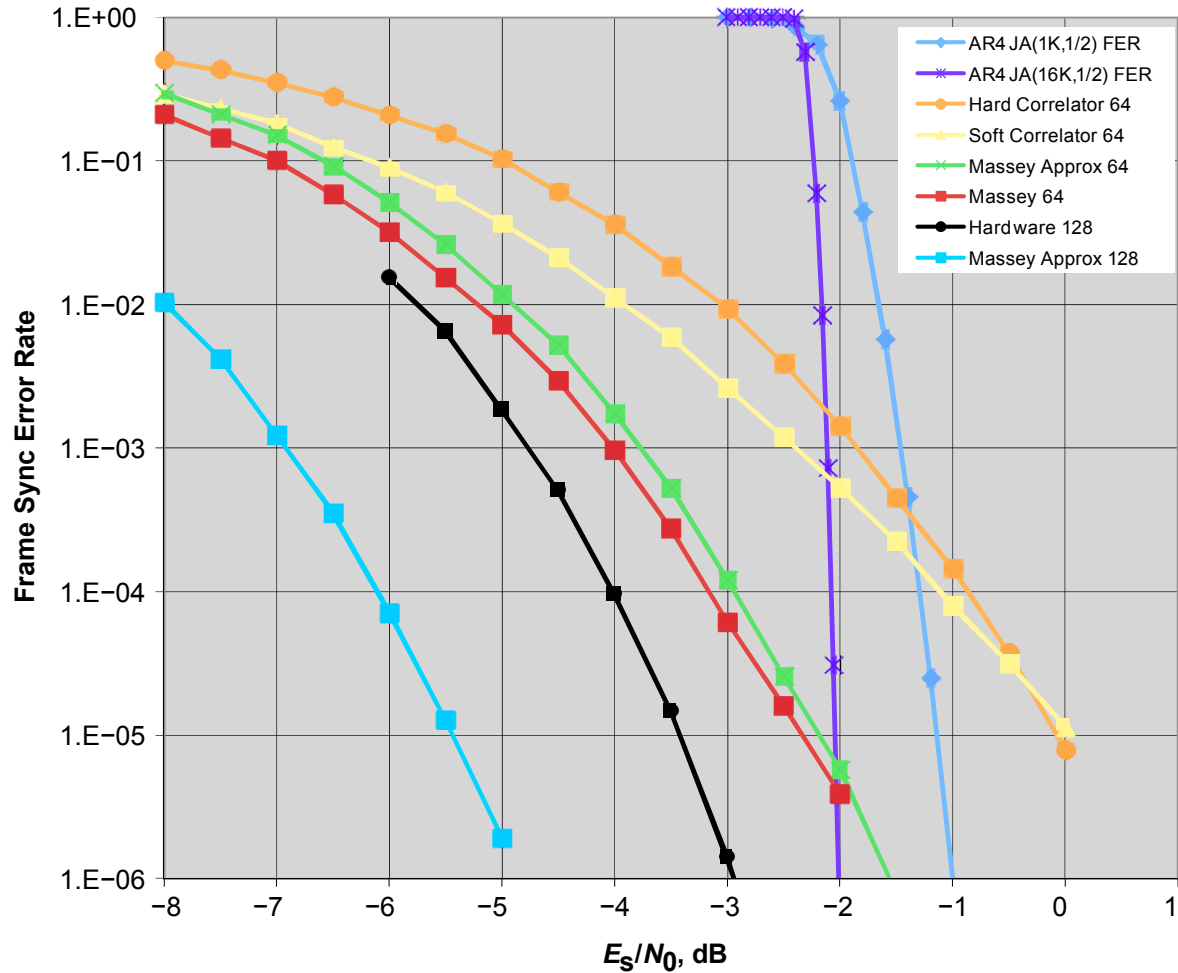

Figure 9-5: Performance of Several Frame Synchronizers, Compared with Two Rate-1/2 LDPC Codes

Figure 9-5 compares the performance of several frame synchronizers in AWGN, and also shows the FERs of LDPC codes for reference, all determined by computer simulation. The steepest blue and purple curves show FERs for short block length AR4JA ($n=2048, k=1024$) and long block length AR4JA ($n=32768, k=16384$) LDPC codes, both of rate 1/2. Using a single 64-symbol marker, performance of the soft correlator is shown in yellow, and the hard correlator is in orange. These curves cross those of the LDPC codes, so the performance of the two algorithms together would be limited by the frame synchronizer at FERs below about 10^{-3} . Performance of the optimal Massey algorithm is in red, and the sub-optimal approximation is in green. It is also possible to verify that the orange, yellow, green, and red

curves in the figure can be predicted very accurately through the analytical tool from reference [67].

By using two 64-symbol markers, frame synchronizer performance can be improved further. Results for the Massey approximation are shown in cyan, and in black for a hardware implementation of this algorithm using 3-bit fixed-point arithmetic and further simplifications to reduce the memory required to store partial results between ASM arrivals.

In addition to resolving codeword synchronization, the frame synchronizer is typically tasked with resolving the phase ambiguity present with Phase Shift Keying (PSK) modulations. With BPSK, the data stream may be complemented, and one simple solution is to build two copies of the frame synchronizer, one to search for each of the marker polarities. The one returning the higher score is selected. This method is optimal for jointly estimating the location and polarity of the marker. With QPSK, OQPSK, or 16-APSK, there are four possibilities that must be identified; with 8-PSK, there are eight possibilities; and so on. One can search over these possibilities consecutively, or implement further copies of the synchronizer. In these copies, some of the logic may be shared, particularly among the adder trees and the control logic, so considerably less than four (or eight) times the complexity is involved. Optimum as well as low-complexity frame synchronization techniques for PSK signaling in presence of a phase offset and AWGN have also been developed in reference [69].

9.4 CERTIFICATION OF THE DECODED DATA (FRAME INTEGRITY CHECKS)

9.4.1 GENERAL

The CCSDS applications are packet-oriented, which means that data are collected and transmitted in frames. With all coding options, and also for uncoded data, it is important to have a reliable indication whether the decoded data is correct. A frame integrity check can be used at the receiver side to validate the received frame or, when suitable, for requiring retransmission in case of check failure.

As with the problem of randomizing the coded output, a universal solution to this data validation problem exists in the form of a Cyclic Redundancy Check (CRC) code, as specified in the *TM Space Data Link Protocol Blue Book* (reference [2]).

9.4.2 DESCRIPTION OF THE RECOMMENDED CRC CODE

9.4.2.1 Background

The Frame Error Control Field (FEFCF) of the TM/TC Transfer Frame is more commonly known in coding theory as CRC, that is, a binary systematic linear code used to detect bit errors after transmission. Usually, the term CRC refers to the parity bits produced by the encoding circuit, which are appended to the message before transmission. The concatenation

of bit message and CRC is known as a codeword. Rather than a cyclic code, the CRC is usually a shortened cyclic code.

The CRC encoding and error detection procedure is conveniently described through polynomials in binary algebra. A message of k bits is represented as a polynomial of degree $k-1$ over the $GF(2)$. More specifically, a k -bits message $[M_0, M_1, \dots, M_{k-2}, M_{k-1}]$ is conventionally represented as a polynomial

$$M(X) = M_0 X^{k-1} + M_1 X^{k-2} + \dots + M_{k-2} X + M_{k-1},$$

where $M_i \in GF(2)$ for $i=0, \dots, k-1$ and where the coefficient M_0 of the highest power of X is the bit transferred first.⁹ Adopting this description, a $(n-k)$ -bits CRC is computed as the remainder

$$P(X) = P_0 X^{n-k-1} + P_1 X^{n-k-2} + \dots + P_{n-k-2} X + P_{n-k-1}$$

of the long division between the degree $n-1$ polynomial $X^{n-k} M(X)$, $M(X)$ being the message polynomial of degree $k-1$, and a degree- $(n-k)$ generator polynomial $G(X)$. Formally:

$$X^{n-k} M(X) = G(X) Q(X) + P(X),$$

where $Q(X)$ is the quotient of the division (which is not used), or

$$P(X) = X^{n-k} M(X) \bmod G(X). \quad (5)$$

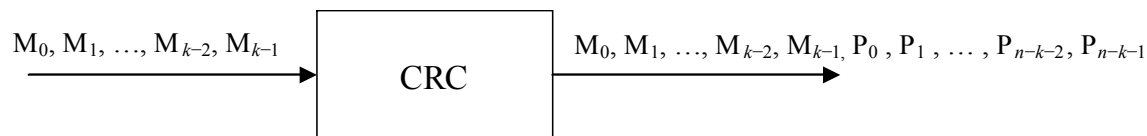

Figure 9-6: CRC Encoding Principle

The CRC encoding principle is sketched in figure 9-6, where the message bit M_0 is input first to the encoder and the encoded bits are output in the order M_0, \dots, P_{n-k-1} .

The CRC encoder is conveniently implemented using Linear Feedback Shift-Register (LFSR) circuits (reference [56]).

The CRC error detection is based on the following observation (using binary algebra):

$$X^{n-k} M(X) = G(X) Q(X) + P(X) \Rightarrow X^{n-k} M(X) + P(X) = G(X) Q(X),$$

where $X^{n-k} M(X) + P(X)$ is the polynomial representation of the transmitted codeword, which is divisible by $G(X)$. Let

$$C^*(X) = C^*_0 X^{n-1} + C^*_1 X^{n-2} + \dots + C^*_{n-2} X + C^*_{n-1}$$

⁹ This convention is consistent, for example, with references [2], [55], [7], and [5].

denote the n -bits received message on the decoder side. Here, the remainder

$$S(X) = S_0 X^{n-k-1} + S_1 X^{n-k-2} + \dots + S_{n-k-2} X + S_{n-k-1}$$

of the division between $C^*(X)$ and $G(X)$ is checked. This remainder is known as the *syndrome*. Formally:

$$S(X) = C^*(X) \bmod G(X). \quad (6)$$

If the syndrome is the all-‘zero’ string, then the received message is a valid codeword and the transmission is assumed to be correct, and incorrect otherwise. An undetected error takes place when the syndrome is the all-‘zero’ string but the transmitted codeword is affected by errors. The CRC syndrome is checked by LFSR circuits that are essentially the same as those used for the encoder (reference [56]).

9.4.2.2 Error Detection

For any (n, k) linear block code, an undetected error occurs when the error pattern is a non-‘zero’ codeword. Generally speaking, a binary (n, k) CRC code, obtained by shortening a cyclic code, is capable of detecting the following error patterns:

- a) all error bursts of length $n-k$ or less;¹⁰
- b) a fraction of error bursts of length equal to $n-k+1$; this fraction equals $1-2^{-(n-k-1)}$;
- c) a fraction of error bursts of length greater than $n-k+1$; this fraction equals $1-2^{-(n-k)}$;
- d) all error patterns containing $d_{\min}-1$ (or fewer) errors, d_{\min} being the minimum distance of the CRC code;
- e) all error patterns with an odd number of errors if the generator polynomial $G(X)$ for the code has an even number of nonzero coefficients.¹¹

9.4.3 CCSDS CRC-16

9.4.3.1 Encoding and Syndrome Calculation

The 16-bit FECF ($n-k=16$) recommended by the CCSDS for the TM Space Data Link Protocol (reference [2]), TC Space Data Link Protocol (reference [55]), Space Packet Protocol (reference [7]), and AOS Space Data Link Protocol (reference [5]) is the 16-bit CRC CCITT, with generating polynomial

$$G(X) = X^{16} + X^{12} + X^5 + 1. \quad (7)$$

¹⁰ Every cyclic code can detect any burst of $n-k$ or less errors (reference [57], Theorem 8.5). Shortened cyclic codes maintain this property.

¹¹ Observe that: 1) if $G(X)$ has an even number of non-zero coefficients, then it has $(X+1)$ among its factors; 2) any binary polynomial with an odd number of non-zero coefficients cannot be divided by $(X+1)$.

A necessary and sufficient condition for the corresponding binary (n, k) code to be cyclic is that $G(X)$ is a factor of X^n+1 . The smallest n such that this condition is fulfilled is $n=32767$ ($2^{15}-1$), so that selecting $k=32751$ leads to a $(32767, 32751)$ cyclic code, where the value $n=32767$ is sometimes referred to as the natural length. Selecting $k < 32751$, the obtained code is a shortened cyclic code. The CRC CCITT code has a guaranteed minimum distance of 4 if $1 \leq k \leq 32751$.

Encoding for the CRC CCITT can be performed using the LFSR circuit depicted in figure 9-7. Provided all the shift register storage cells are initialized to '0', the coefficients of the remainder $P(X)$ are stored in the cells in the clock time in which the bit M_{k-1} is output by the encoding circuit. A LFSR circuit that allows checking the syndrome of the received word $C^*(X)$ is sketched in figure 9-8. This circuit is essentially the same used for encoding. Assume all the storage cells of the shift register are initialized to '0'. The syndrome of $C^*(X)$ is present in the shift register cells in the time clock subsequent to that in which the bit C_{n-1}^* is input to the circuit. It is worthwhile noting that, using this circuit, one will actually check the remainder of the division between $X^{n-k} C^*(X)$ and $G(X)$: since $G(X)$ has not X among its factors, the syndrome of $C^*(X)$ is zero if and only if the syndrome of $X^{n-k} C^*(X)$ is zero.

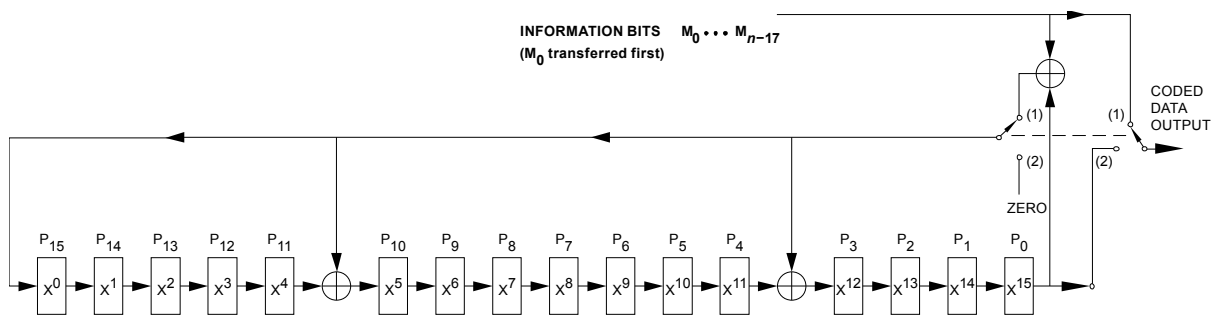

Figure 9-7: Logic Diagram of the Encoder

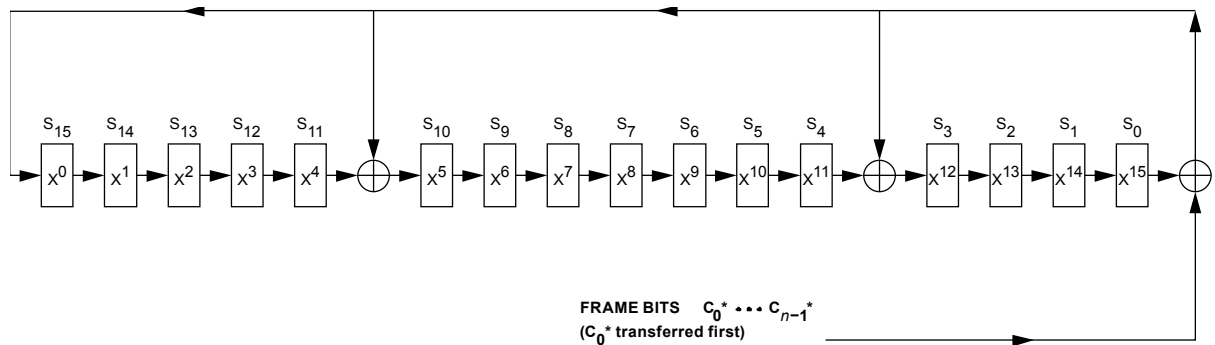

Figure 9-8: Logic Diagram of the Decoder

The initial value of the shift register storage cells has in principle no effect on the CRC undetected error probability. However, there might be practical considerations leading to use an initial word instead of another one. For example, any CRC encoder for which all the shift

register storage cells are initialized to ‘0’ has no state transition if an all-‘zero’ message is input. In some situations, a non-‘zero’ initial word may be preferred. A non-‘zero’ initial word is recommended in reference [2], in which the encoding and syndrome computation rules are slightly different from equations (5) and (6). A degree-15 presetting polynomial

$$L(X) = \sum_{i=0}^{15} X^i \quad (8)$$

is first introduced, corresponding to the all-one sequence of length 16. Then, the FECF (encoding side) and the syndrome (decoding side) are computed as

$$\text{FECF} = [(X^{16} \cdot M(X)) + (X^{(n-16)} \cdot L(X))] \bmod G(X) \quad (9)$$

and

$$S(X) = [(X^{16} \cdot C^*(X)) + (X^n \cdot L(X))] \bmod G(X), \quad (10)$$

respectively. It is possible to show that equations (9) and (10) correspond to input $M(X)$ and $C^*(X)$ to the encoding and decoding circuits, respectively, presetting in both circuits all the storage cells to ‘1’ (a proof can be found, for instance, in reference [58]).

Serial concatenation of CRC encoding (FECF addition) and Turbo encoding is shown in figure 9-9.

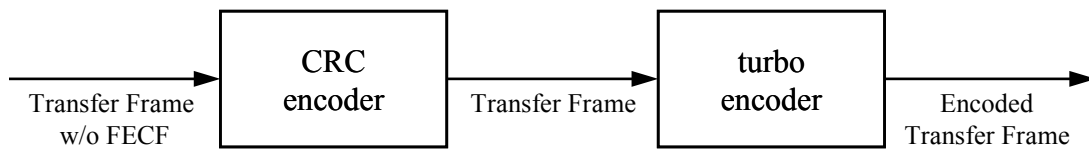

Figure 9-9: Turbo-CRC Encoder

At the transmitter side, the FECF is added to the information frame by the CRC encoder, before entering the Turbo encoder. The CRC syndrome (FECF) is used to check the integrity of the decoded frame produced by the Turbo decoder at the receiver side.

9.4.3.2 Error Detection

If $1 \leq k \leq 32751$ the CCSDS CRC-16 is capable to detect

- a) all error bursts of length 16 or less;
- b) a fraction of error bursts of length equal to 17; this fraction equals $1-2^{-15}$;
- c) a fraction of error bursts of length greater than 17; this fraction equals $1-2^{-16}$;
- d) all error patterns containing 1, 2, or 3 errors;
- e) all error patterns with an odd number of errors.

For independent errors and bit error probability P_e , letting A_w denote the multiplicity of the weight- w codewords, the undetected error probability can be expressed as

$$P_u = \sum_{i=1}^n A_i P_e^i (1 - P_e)^{n-i} . \quad (11)$$

For small enough P_e , equation (11) is well approximated by considering only those terms in the summation that are associated with minimum-weight codewords. More in general, by considering only this term, a lower bound on the undetected error probability is obtained. Therefore, if the bit errors occur independently with error probability $P_e \ll 1$, the undetected error probability of the CCSDS CRC-16 can be approximated as

$$P_u \approx A_4 \cdot P_e^4 \cdot (1 - P_e)^{n-4} .$$

Some values of A_4 as functions of k are provided in reference [59], in which it is also advised that common operations such as *bit stuffing* can increase the undetected error probability. An analysis of the undetected error probability of cyclic and shortened cyclic codes (including the CRC-16 with generator polynomial [equation (7)]) affected by probabilistic burst errors can be found, for instance, in references [60] and [61].¹²

9.4.4 USAGE CIRCUMSTANCES FOR THE RECOMMENDED CRC CODE

The recommended CRC code is included in the Telemetry Frame and consists of 16 check bits computed from the remainder of the frame contents. This code can reliably detect incorrect frames with an undetected error rate of around $2^{-15} \approx 3 \cdot 10^{-5}$. This CRC code achieves approximately the same undetected error rate for any of the recommended telemetry channel codes.

A much lower undetected error rate is achieved when the RS code with $E = 16$ is used, either by itself or concatenated with an inner convolutional code. In this case, the undetected error rate of the RS decoder is on the order of $1/E! \approx 5 \cdot 10^{-14}$, which is many orders of magnitude better than the validation offered by the CRC code. Thus the error detection capability of the CRC code is superfluous when the RS code with $E = 16$ is used.

The RS code with $E = 8$ offers much lower error detection capability, on the same order as that provided by the 16-bit CRC code. Similarly, a Turbo decoder equipped with a smart stopping rule that notes whether the decoder's iterations converge to a valid codeword can achieve some degree of error detectability and somewhat alleviate the need for the 16-bit CRC code. However, in these borderline cases the CRC code is still required. It is also required for uncoded data or convolutionally coded data, which offer absolutely no capability for error detection on their own.

¹² The expression (b, p) probabilistic burst error is used sometimes to refer to a burst error of length b in which each of the $b-2$ intermediate encoding bits is in error with probability p .

If a lower detected error rate is desired than that offered by the recommended 16-bit CRC code, and RS coding is not used, then one option is to use a 32-bit or 48-bit CRC code (not in the CCSDS Recommended Standards).

9.5 CODE TRANSPARENCY

Rotationally invariant (transparent) coding schemes are used to overcome the phase ambiguity inherent in usual coherent demodulation techniques. For the transmission over a band-limited channel using phase-coherent demodulation, to estimate the carrier phase, the receiver uses its knowledge of the signal set S , which is the set of points produced by the modulator. By examining the pattern of received signal points, the receiver can infer the carrier phase up to an ambiguity corresponding to a rotational symmetry of S .

A counterclockwise rotation of x degrees about the origin is denoted by ρ . A rotational symmetry of the signal set S is a rotation ρ mapping S into itself. The set of all the rotational symmetries of S is called the rotational symmetry group ϕ . If ϕ has n elements then it is a cyclic group generated by the rotation ρ of $x = 360/n$ degrees (the smallest non-zero rotation belonging to it).

As an example, an M -PSK constellation has M rotational symmetries. In particular, a 2-PSK constellation has 2 rotational symmetries: $\phi = \{\rho_0, \rho_1\}$, while a 4-PSK constellation has 4 rotational symmetries $\phi = \{\rho_0, \rho_1, \rho_2, \rho_3\}$, as a square QAM constellation (16-QAM, 64-QAM, 256-QAM), where $\rho_i = 90^\circ \cdot i$. For non-square QAM constellations, ϕ depends on the signal choice.

When used in a modulation scheme with coherent demodulation, the carrier phase is estimated from the ensemble of the received signal points. However, an ambiguity corresponding to a rotation of ϕ cannot be solved without external reference. For example, if a 2-PSK is used, the demodulator observes the two received points and estimates a carrier phase that can be correct, or wrong by 180 degrees.

The receiver can handle the n -way phase ambiguity in several ways. One way to resolve the phase ambiguity is through training. At the start of the transmission, and during it, the transmitter sends a predetermined sequence of signal points that the receiver uses to correct its phase estimation.

Another method uses transparent coding schemes to solve the problem. In this case, the receiver does not try to resolve the possible phase error but uses transparent schemes able to cope with it. For an uncoded signal set $S=2$ -PSK transmitted over a channel without noise, if a 180-degree phase change occurs at the receiver side, all the transmitted bits are received inverted. A simple differential precoder at the transmitter side followed by a differential postcoder at the receiver can cope with this situation (see figure 3-1 and figure 9-10 below).

For a binary code C mapped over $S=2$ -PSK, the precoder/postcoder operation could still be applied to cope with possible phase errors. However, it is essential that a rotation of 180 degrees maps the code into itself (otherwise, in case of phase error, the decoder would work over a different set of codewords). In this case, it can be said that C is rotationally invariant (transparent): for any code sequences $c \in C$, its inverted version still belongs to C ; a differential precoder/postcoder pair is able to solve the phase ambiguity of the coded sequences.

9.6 REMAPPINGS OF THE BITS

In figure 3-1, there is an optional ‘NRZ-L to NRZ-M conversion’ block at the transmitter and, inversely, an ‘NRZ-M to NRZ-L conversion’ block at the receiver. NRZ-L is a modulation format that represents a data ‘1’ by one of two levels, and a data ‘0’ by the other level. On the other hand, NRZ-M represents a data ‘1’ by a change in level and a data ‘0’ by no change in level. The conversion from NRZ-L to NRZ-M is a form of differential precoding that can be used to resolve the ambiguity between true and complemented data. Figure 9-10 shows a block diagram for implementing the ‘NRZ-L to NRZ-M conversion’ and its inverse.

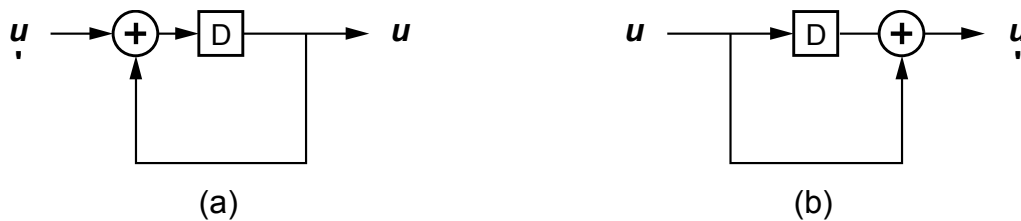

Figure 9-10: Block Diagrams for Implementing the (Optional) (a) ‘NRZ-L to NRZ-M Conversion’ and (b) Its Inverse

When all three elements of the coding system depicted in figure 3-1 are used, the ‘NRZ-L to NRZ-M conversion’ is actually just a form of 1:1 mapping applied to the binary data, not a conversion of modulation formats, since the modulation of the data occurs after the convolutional encoding stage. Any invertible mapping may be applied to the binary data without apparent consequence as long as all the data bits are correct; however, performance is affected by 1:1 mappings when errors enter the system. For example, there is a large performance penalty if one puts an NRZ-L to NRZ-M mapping at the output of a convolutional code (see reference [31]). For this reason, figure 3-1 does not include an option that allows an ‘NRZ-L to NRZ-M conversion’ block to serve as a true modulation conversion at the output of the convolutional encoder.

The CCSDS Recommended Standards (references [3] and [2]) do not regulate whether a user’s source data might be subjected to a 1:1 mapping (or any other form of data processing) before being packaged as information bits in a Telemetry Transfer Frame prior to coding. Thus any form of 1:1 mapping of the source data that precedes any of the recommended CCSDS codes is implicitly allowed by Recommended Standards (references [3] and [2]). In

this case, the code performance curves shown in this Green Book pertain only to the error rates for the remapped data presented to the encoder. The user has the responsibility to determine whether these errors might propagate or multiply throughout the original source data as a result of the 1:1 premapping. For example, the discussion following figure 5-4 mentioned two methods (row-by-row and column-by-column) for reading the source data into the matrix used for interleaving RS codewords; this choice affects the characteristics of errors in the decoded source data.

The ‘NRZ-L to NRZ-M conversion’ block in figure 3-1 can be viewed simply as an implicitly permitted 1:1 remapping of the source data in the case when the RS code is not used. Curiously, however, the figure also indicates that this mapping may be placed *between* the two components of a concatenated code. This placement makes sense from a performance standpoint: unlike an NRZ-L to NRZ-M mapping at the output of a convolutional code, the same mapping applied to RS coded bits has only minor effects on the code’s performance. However, in this position this remapping in fact makes the overall code a concatenation of three codes, not two, when all three elements of the coding system depicted in figure 3-1 are used. The Blue Book (reference [3]) does not clearly state that such an arrangement is permitted. Also, figure 3-1 fails to show where the optional ‘NRZ-L to NRZ-M conversion’ block between the RS and convolutional codes fits with respect to the interleaving of RS codewords.

ANNEX A

GLOSSARY

block encoding: A one-to-one transformation of sequences of length k of elements of a source alphabet to sequences of length n of elements of a code alphabet, $n > k$.

channel symbol: The unit of output of the innermost encoder that is a serial representation of bits, or binary digits, which have been encoded to protect against transmission induced errors.

clean data (bits): Data (bits) that are error free within the error detection and optional error correction capabilities of the TM system.

code rate: The average ratio of the number of binary digits at the input of an encoder to the number of binary digits at its output.

codeblock: The aggregation of I codewords, where I is the interleaving depth. In reference [3], the term Codeblock is used for RS coding, and when $I=1$, the terms Codeblock and Codeword are used interchangeably.

codeword: In a block code, one of the sequences of length n in the range of the one-to-one transformation (see Block Encoding).

command link control word, CLCW: The Telecommand System Transfer Layer protocol data unit for Telecommand reporting via the TM Transfer Frame Operational Control Field.

concatenation: The use of two or more codes to process data sequentially with the output of one encoder used as the input of the next.

connection vector (backward): In Turbo coding, a vector used to specify the feedback to the shift registers in the encoder. For a shift register with s stages, a backward connection vector is an s -bit binary number. A bit equal to one in position i (counted from the left) indicates that the output of the i th stage of the shift register is to be used in computing the feedback value, except for the leftmost bit, which is ignored.

connection vector (forward): In convolutional and Turbo coding, a vector used to specify one of the parity checks to be computed by the shift register(s) in the encoder. For a shift register with s stages, a connection vector is an s -bit binary number. A bit equal to one in position i (counted from the left) indicates that the output of the i th stage of the shift register is to be used in computing that parity check.

constraint length: In convolutional coding, the number of consecutive input bits that are needed to determine the value of the output symbols at any time.

convolutional code: As used in this document, a code in which a number of output symbols are produced for each input information bit. Each output symbol is a linear combination of

the current input bit as well as some or all of the previous $K-1$ bits, where K is the constraint length of the code. Differently from block codes, convolutional codes act on stream of data and do not require any fixed block length.

fill bit(s): Additional bit(s) appended to enable a ‘data entity’ to exactly fit an integer number of octets or symbols.

inner code: In a concatenated coding system, the last encoding algorithm that is applied to the data stream. The data stream here consists of the codewords generated by the outer decoder.

modulating waveform: A way of representing data bits (‘1’ and ‘0’) by a particular waveform.

NRZ-L: A data format representation in which a data ‘one’ is represented by one of two levels, and a data ‘zero’ is represented by the other level.

NRZ-M: A data format representation in which a data ‘one’ is represented by a change in level and a data ‘zero’ is represented by no change in level.

octet: An 8-bit word consisting of eight contiguous bits.

outer code: In a concatenated coding system, the first encoding algorithm that is applied to the data stream.

packet: An efficient application-oriented protocol data unit that facilitates the transfer of source data to users.

protocol: A set of procedures and their enabling format conventions that define the orderly exchange of information between entities within a given layer of the TM System.

Reed-Solomon symbol, RS symbol: A set of J bits that represents an element in the $GF(2^J)$, the code alphabet of a J -bit RS code.

reliable: Meets the quality, quantity, continuity, and completeness criteria that are specified by the TM System.

segment: A protocol data unit that facilitates telemetry flow control through the breaking of long source packets into communications-oriented data structures.

systematic code: A code in which the input information sequence appears in unaltered form as part of the output codeword.

telemetry system: The end-to-end system of layered data handling services that exist to enable a spacecraft to send measurement information, in an error-controlled environment, to receiving elements (application processes) in space or on Earth.

transfer frame: A communication-oriented protocol data unit that facilitates the transfer of application-oriented protocol data units through the space-to-ground link.

transparent code: A code that has the property that complementing the input of the encoder or decoder results in complementing the output.

trellis termination: The operation of filling with ‘zeros’ the s stages of each shift register used in the Turbo encoder, after the end of the information block. During trellis termination the encoders continue to output encoded symbols for $s-1$ additional clock cycles.

turbo code permutation: A fixed bit-by-bit permutation of the entire input block of information bits performed by a permuter or interleaver, used in Turbo codes.

turbo code: As used in this document, a block code formed by combining two component recursive convolutional codes. A Turbo code takes as input a block of k information bits. The input block is sent unchanged to the first component code and bit-wise interleaved (see Turbo code permutation) to the second component code. The output is formed by the parity symbols contributed by each component code plus a replica of the information bits.

user: A human or machine-intelligent process that directs and analyzes the progress of a space mission.

virtual channel, VC: A given sequence of Transfer Frames, which are assigned a common identification code (in the Transfer Frame header), enabling all Transfer Frames who are members of that sequence to be uniquely identified. It allows a technique for multiple source application processes to share the finite capacity of the physical link (i.e., through multiplexing).

virtual fill: In a systematic block code, a codeword can be divided into an information part and a parity (check) part. Suppose that the information part is N symbols long (symbol is defined here to be an element of the code’s alphabet) and that the parity part is M symbols long. A ‘shortened’ code is created by taking only S ($S < N$) information symbols as input, appending a fixed string of length $N-S$ and then encoding in the normal way. This fixed string is called ‘fill’. Since the fill is a predetermined sequence of symbols, it need not be transmitted over the channel. Instead, the decoder appends the same fill sequence before decoding. In this case, the fill is called ‘Virtual Fill’.

ANNEX B

ACRONYMS AND ABBREVIATIONS

AOS	Advanced Orbiting Systems
APP	a-posteriori probability
ASM	attached synchronization marker
AWGN	additive white Gaussian noise
BCH	Bose-Chaudury-Hoquenheim
BER	bit error rate
BPSK	binary phase shift keying
BSNR	bit signal-to-noise ratio
CCSDS	Consultative Committee on Space Data Systems
CRC	cyclic redundancy check
DSN	Deep Space Network
ESA	European Space Agency
FEC	forward error correction
FER	frame error rate
GF	Galois field
GSFC	Goddard Space Flight Center
JPL	Jet Propulsion Laboratory
LDPC	low density parity check
MAP	maximum a-posteriori probability
NASA	National Aeronautics and Space Administration
NRZ	non-return to zero
PM	phase modulated
PSK	phase shift keying
QAM	quadrature amplitude modulation
RF	radio frequency

RFI	radio frequency interference
ROM	read only memory
RS	Reed-Solomon
SNR	signal-to-noise ratio
SSNR	symbol SNR
TM	telemetry
VC	virtual channel
WER	word error rate

ANNEX C

QUANTIZATION STRATEGIES FOR SOFT-DECODING

Quantization acts on the signal at the output of the channel, that is, at the output of the demodulator and immediately prior to the decoder. Precisely how that transition between demodulator and decoder is accomplished may directly impact the success of the decoder, regardless of how that success is measured. Any decoder that relies upon trellis-based iterative estimation algorithms will steadfastly rely upon numerical approximations in the first place to accommodate both the exponential and its inverse (logarithmic) operators that occur frequently in their execution. Those numerical approximations are in turn sensitive to input range and levels of discretization. As will be demonstrated here, it is not always true that smaller discrete transitions in the quantizer will necessarily result in improvements in decoder output.

Quantizers can be characterized as either uniform or non-uniform depending upon the consistency of step transition size, as midrise or midthread according to whether a step transition occurs at a null input. A signed quantizer composed of q bits plus a sign bit is constructed. Further, the quantization strategy is to bound the quantization by clipping but always offer an equal number of quantization steps ($N=2q$) between bounds. For absolute values of the demodulator soft Log-Likelihood Ratio (LLR) output that exceed a specific bound A , the output of the quantizer is forced to A while the sign of the original input to the quantizer is retained. The scheme is symmetric but it is also considered non-uniform. The non-uniformity is the result of the transition at a null input that is twice the quantization level step size. The resulting symmetric, non-uniform, midrise bounded quantizer appears graphically as shown within figure C-1. The bound is normalized to the clipping level A .

For a fixed BPSK signal amplitude ($x=+1$ and $x=-1$), two values of clipping are considered in this annex, both for $q = 4$:

- *Case 1*— $A = 1$ (n Quant8 Thr1); and
- *Case 2*— $A = 2$ (Quant8 Thr2).

Section 4 employs the second clipping threshold ($A = 2$) for $q = 3$ and 6. It is possible to verify that the adoption of such law (even with $q = 8$ quantization bits) gives a performance loss for the lowest code rates, while no loss usually appears for the highest code rates.

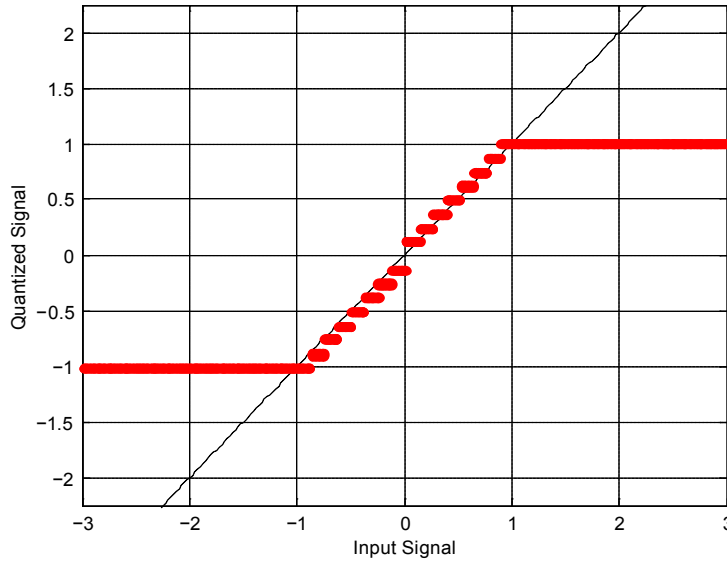

NOTE – Quantizer bounds are normalized to the clipping level A.

Figure C-1: Realization of Symmetric, Non-Uniform, Midrise Quantizer, $q = 4$

In other terms, the loss due to quantization decreases for increasing values of the signal-to-noise ratio. This suggests that such loss could depend on the effect of clipping of the channel messages due to the quantization law adopted. In fact, the impact of clipping decreases when the noise variance decreases, that is, for increasing values of signal-to-noise ratio.

The quantization law of the Quantization Clipping Threshold 2 has the same form but shows a higher clipping threshold (equal to 2). The modified law is shown in figure C-2, for the case with $q = 4$ quantization bits.

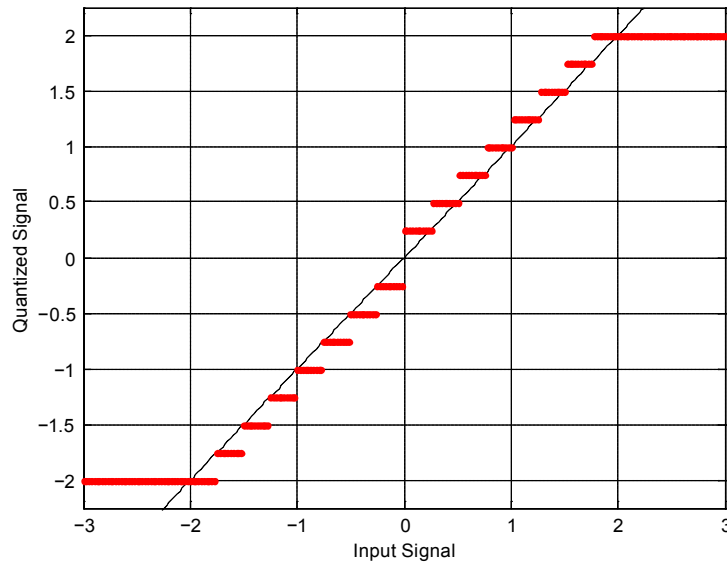

Figure C-2: Quantization Law When Using the Quantization Strategy 2, for the Case of $q = 4$

Obviously, when the same number of quantization bits is used, the modified quantization law has an increased clipping threshold but also an increased quantization step ($d = 4/N$, for the case $A = 2$). It can be verified that the benefit of reducing the clipping effect can be more important than the drawback of increasing the quantization step.

As an example, it is possible to consider the two recommended CC+RS concatenated codes with the lowest code rate ($R = 1/2$) and the highest code rate ($R = 7/8$), by assuming $q = 8$ quantization bits.

Simulation results (reported in figure C-3) show that, at both code rates, the Quantization Clipping Threshold 2 (denoted as ‘Quant8 Thr2’ in the figure) gives performance practically coincident with that in absence of quantization, thus confirming that the loss observed with the Quantization Clipping Threshold 1 (denoted as ‘Quant8 Thr1’ in the figure) was mainly the result of the clipping effect.

The same conclusion can be drawn for the code rate values comprised between the considered ones.

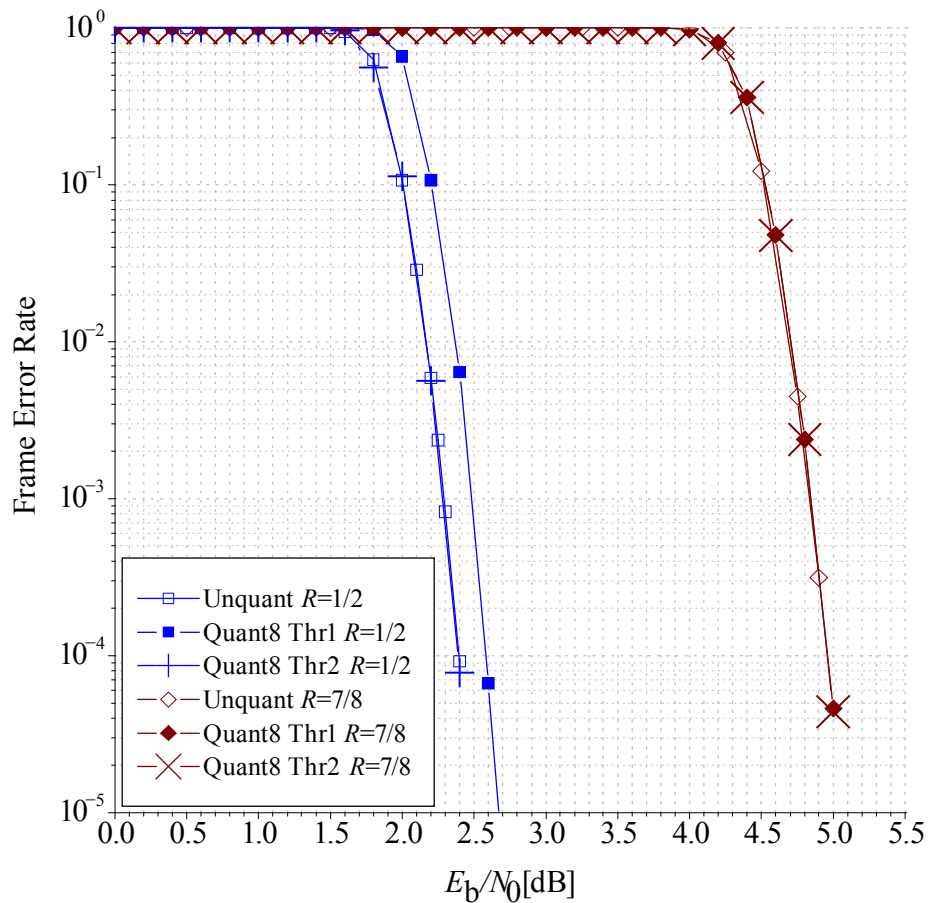

Figure C-3: Example of Comparison between Quantization Clipping Threshold 1 and Quantization Clipping Threshold 2, When Applied to CC+RS Concatenated Codes with $R = 1/2$ and $R = 7/8$

ANNEX D

RATIONALE FOR TURBO CODE PARAMETER SELECTIONS

D1 GENERAL

Because Turbo codes can achieve great performance over a wide range of parameter values, the selection of reasonable code parameters is a major systems issue. The system design must assess all the parameter-space tradeoffs as they affect both the performance of the code and systems-related considerations. Turbo codes give the system designer vast flexibility to choose any desirable combination of parameters without sacrificing performance more than intrinsically necessary.

D2 CODE RATE

The code rate of the recommended Turbo encoder is selectable from 1/2, 1/3, 1/4, or 1/6. Lower code rates are also possible to achieve even better performance if the receivers can work at the correspondingly lower channel-symbol SNR (E_b/N_0). The rule of thumb is that the potential coding gain for using lower code rates pretty much follows the corresponding gain for the ultimate code-rate-dependent theoretical limits.

For deep-space applications, Turbo codes are intended for use with BPSK modulation, with code rate < 1 bit/channel symbol (spectral efficiency < 1 bit/sec/Hz). The same codes can be used with QPSK modulation with Gray coding signal assignment to achieve higher spectral efficiency, as is typically required in near-Earth applications.¹³

D3 BLOCK SIZE

Figure 3-4 shows how some fundamental theoretical lower bounds on the performance of arbitrary codes on the AWGN channel vary with block length. Amazingly, this variation is mirrored by the empirically determined dependence on block length of the performance of a large family of good Turbo codes (see also reference [16]).

Figure D-1 shows simulation results compared to the lower bound for a family of rate-1/3 Turbo codes with different block lengths (using the generator polynomials specified in 7.2). It should be noted that the range of block lengths in this figure, from 256 bits up to 49152 bits, spans both larger and smaller block lengths than the five specific CCSDS recommended block lengths. Although there is a 2-dB performance differential between the simulation results for 256-bit blocks and 49152-bit blocks, the difference between the simulations and the lower bounds remains approximately the same. The simulation results are about 0.5 dB to 1.0 dB from the theoretical limits for all code rates ranging from 1/6 to 1/2 and at all block

¹³ Additional Turbo codes with matched modulation signal set have been designed for even higher spectral efficiencies. These codes would require 8PSK or higher-level modulations and are not covered in this document.

sizes ranging from 256 to 49152 information bits. Similar results were obtained for Turbo codes in the same family with rates 1/2, 1/4, and 1/6. The significance of these results is that Turbo codes appear to be uniformly good over the entire span of block sizes shown, including all of the CCSDS recommended block lengths. The bound is plotted for WER=1e-4, while the Turbo code performance is plotted for BER=1e-6. While better consistency could be achieved if Turbo code performance data were available at WER=1e-4, experience shows that for a rate 1/3 Turbo code operating under these conditions, the BER and WER curves are separated by about two orders of magnitude. Moreover, the BER and WER curves are steep, so the threshold E_b/N_0 is not very sensitive to the error rate criterion used.

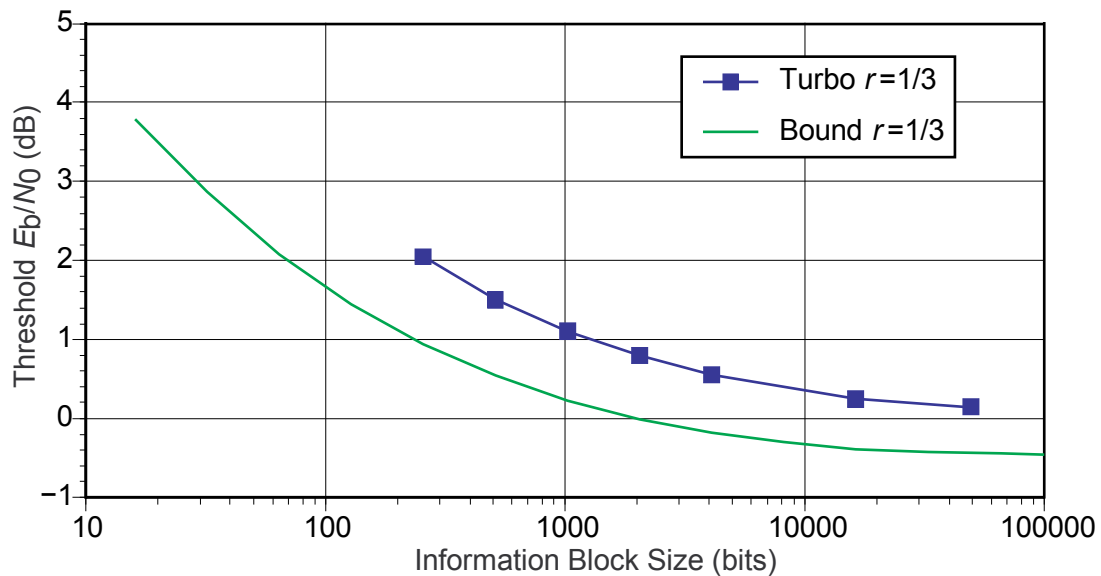

NOTE – Bound is calculated for WER of 10^{-4} , while Turbo code simulations were for BER of 10^{-6} .

Figure D-1: Comparison of Turbo Code Performance with Block Length-Constrained Lower Bound

D4 CONSTITUENT CODES

Effective Turbo codes can be constructed from a wide variety of constituents. Here are some of the factors underlying the choice of constituent codes that led to the recommended CCSDS Turbo codes.

Number and Type of Constituent Codes—Turbo codes with more than two constituent codes are feasible in principle, but to this point they have not been well studied, mainly because two-component Turbo codes already perform so well. The best performing and best understood constituent codes discovered thus far are the class of recursive convolutional codes, as recommended in 7.2 and in the original Turbo code paper by Berrou, et al.

Constraint Length—The recommended Turbo code is formed from two recursive convolutional codes with constraint length $K=5$. Higher constraint lengths are more complex to decode, and they seem to offer negligible performance improvement. In the other direction, constituent codes with constraint lengths less than 5 sacrifice some performance to achieve higher decoding speeds.

Code Generator Polynomials—Considerable theory has been developed to guide the choice of constituent code generator polynomials. This theory is based on the transfer function bounds that are used to predict the Turbo decoder error floor. The error floor can be lowered the most if the divisor polynomial (G_0 in figure 7-3) is a primitive polynomial. Additional theoretical considerations guide the choice of the remaining polynomials.

Code Transparency—Turbo codes are inherently non-transparent, meaning that the complement of a codeword is not a codeword (or equivalently, the all-‘ones’ sequence is not a codeword). However, a Turbo code can be made ‘approximately transparent’ except near the edges of the codeword. It is a system design issue to decide whether an approximately transparent Turbo code would be preferred, at some sacrifice of performance, to one designed without any transparency constraints. The Turbo codes in the Recommended Standard (reference [3]) are *not* constructed to be approximately transparent.

D5 PERMUTATION

The (analytically) best-understood permutations for Turbo codes are completely random. The best-performing permutations are manually optimized for each block size, and they also look very random. Manually optimized permutations generally outperform purely random permutations by only a small amount, except that they may significantly lower the error floor. However, such a permutation needs to be stored in ROM as a lookup table because it is infeasible to recompute it on the fly for every codeword. The permutation in the Recommended Standard (reference [3]) can be generated on the fly by applying a simple rule. It also looks very random and performs nearly as well (within 0.1 dB, see figure D-2) as the manually optimized permutation. The recommended permutation gives the implementer an option to calculate the permutation on-the-fly in preference to using a look-up table. It may be noted that a simple rectangular interleaver, such as the interleaver recommended for RS codes (see 5.3), is not suitable for Turbo codes.

The interpretation of the permutation numbers in the Recommended Standard (reference [3]) is such that the s th bit read out on line ‘in b’ (in figure 7-3) is the $\pi(s)$ th bit of the input information block, as shown in figure D-3.

D6 SOME SYSTEM ISSUES PERTINENT TO THE USE OF TURBO CODES

Lower symbol SNR—To take advantage of the improved performance of Turbo codes, the receiving system must operate at a significantly lower Symbol Signal-to-Noise Ratio (SSNR) than that of a less powerful code with the same code rate. This imposes more stringent demands

on the receiver’s ability to perform symbol synchronization. The performance advantages of Turbo coding may be negated if the receiver cannot lock onto the lower-SSNR symbols.

Since the threshold SSNR drops in direct proportion with the code rate, whereas the threshold Bit Signal-to-Noise Ratio (BSNR) converges to a fixed limit as code rate tends to zero (see 3.3.2), lowering the code rate too far toward 0 produces diminishing returns in overall code performance while continuing to tax the receiver heavily. It is a systems issue to decide on the code rate that provides the best tradeoffs. For Turbo codes, the variation of code performance with code rate more or less mirrors that of the ultimate limits on performance, as given in 3.3.2.

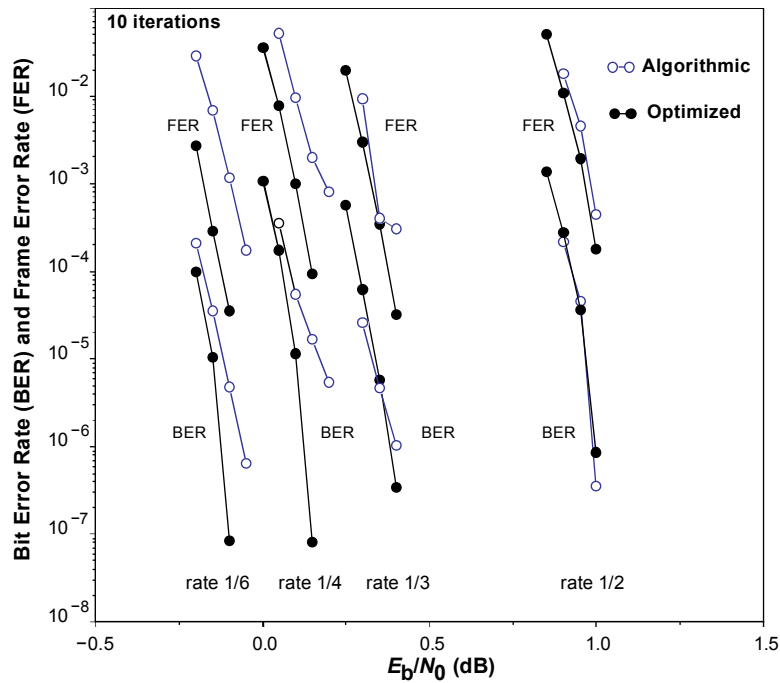

Figure D-2: Performance Comparison for Pseudo-Random and Algorithmic Permutations

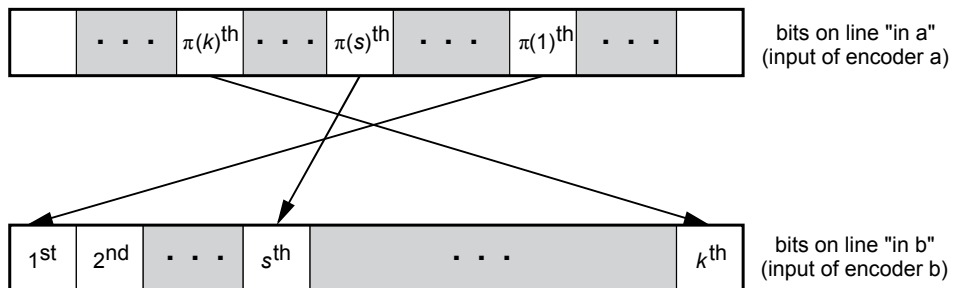

Figure D-3: Interpretation of Permutation

Performance with Non-Ideal Tracking Loops—Any decoder’s performance degrades when there are small errors in tracking and detecting the received symbols. However, with Turbo codes, there is also a possibility to improve the receiver’s tracking performance by feeding back soft information from the decoding process to assist the receiver’s tracking loops. Preliminary assessments (see reference [20]) of potential improvements are encouraging.

Residual Error Correction—In applications requiring extremely low error rates, the error rate of a Turbo code in the error floor region may be unacceptable despite best efforts to lower it. The solution may be to add an outer code to work in conjunction with the Turbo code as the inner code. The outer code would ideally be a binary code such as a Bose-Chaudury-Hoquenheim (BCH) code rather than a nonbinary RS code. Because of the sparseness of errors on the error floor (typically a handful of bit errors per block), the outer code could have a very high code-rate and would shift the required E_b/N_0 by just a tiny amount. However, an outer code will provide very little benefit at signal-to-noise ratios below the error floor region, because in this region there are frequently codewords for which the Turbo decoding algorithm fails to converge, and the resulting number of bit errors is beyond the error correction capability of any reasonable outer code. Unfortunately, these errors due to non-convergence of the decoding algorithm do not completely disappear in the error floor region, where they are similarly immune to being corrected by a reasonable outer code. Thus even in the error floor region, an outer code is only effective in fixing the dominant error events, but the rarer events in this region (due to non-convergence) may still exceed the desired error rate if they are not rare enough.

Detecting Turbo Decoding Errors with an Outer CRC Code—Turbo decoders (like Viterbi decoders) are *complete* decoders, in that they always produce a decoded sequence. Currently these decoders do not detect and mark unreliable sequences, though in principle they could be modified to do so. Alternatively, a separate error detection code, such as a CRC code, can be concatenated as an outer code with an inner Turbo code, in order to flag unreliable decoded sequences. If ℓ is defined by the redundancy of the error detection code (CRC), the $\ell=16$ CRC code used for the CCSDS standard detects every possible error sequence \mathbf{e} with the lowest weights $|\mathbf{e}| = 1, 2, \text{ or } 3$. An undetected codeword error occurs whenever the error pattern \mathbf{e} of the sequence decoded by the Turbo code equals one of the nonzero codewords of the CRC code. The CRC/Turbo code combination will produce a typical undetected error probability (in the case of a Turbo decoder error) of about $2^{-\ell} = 2^{-16} \approx 1.5 \times 10^{-5}$. This value must be multiplied by the probability of a codeword error to obtain the (unconditional) undetected error probability.

Lowering the Turbo Code’s Error Floor—Even without using an outer BCH code, it has been possible to design good Turbo codes that lower the error floor to possibly insignificant levels (e.g., 10^{-9} BER). Such performance may be sufficiently good for space applications to obviate the need for an outer error-correcting code. In that case, a simpler outer code (such as a CRC code) may still be desirable for error detection only.