

Recommendation for Space Data System Standards

CCSDS SPACE LINK PROTOCOLS OVER ETSI DVB-S2 STANDARD

RECOMMENDED STANDARD

CCSDS 131.3-B-2

BLUE BOOK
April 2022

Recommendation for Space Data System Standards

**CCSDS SPACE LINK
PROTOCOLS OVER
ETSI DVB-S2 STANDARD**

RECOMMENDED STANDARD

CCSDS 131.3-B-2

BLUE BOOK
April 2022

AUTHORITY

Issue:	Recommended Standard, Issue 2
Date:	April 2022
Location:	Washington, DC, USA

This document has been approved for publication by the Management Council of the Consultative Committee for Space Data Systems (CCSDS) and represents the consensus technical agreement of the participating CCSDS Member Agencies. The procedure for review and authorization of CCSDS documents is detailed in *Organization and Processes for the Consultative Committee for Space Data Systems* (CCSDS A02.1-Y-4), and the record of Agency participation in the authorization of this document can be obtained from the CCSDS Secretariat at the email address below.

This document is published and maintained by:

CCSDS Secretariat
National Aeronautics and Space Administration
Washington, DC, USA
Email: secretariat@mailman.ccsds.org

STATEMENT OF INTENT

The Consultative Committee for Space Data Systems (CCSDS) is an organization officially established by the management of its members. The Committee meets periodically to address data systems problems that are common to all participants, and to formulate sound technical solutions to these problems. Inasmuch as participation in the CCSDS is completely voluntary, the results of Committee actions are termed **Recommended Standards** and are not considered binding on any Agency.

This **Recommended Standard** is issued by, and represents the consensus of, the CCSDS members. Endorsement of this **Recommendation** is entirely voluntary. Endorsement, however, indicates the following understandings:

- o Whenever a member establishes a CCSDS-related **standard**, this **standard** will be in accord with the relevant **Recommended Standard**. Establishing such a **standard** does not preclude other provisions which a member may develop.
- o Whenever a member establishes a CCSDS-related **standard**, that member will provide other CCSDS members with the following information:
 - The **standard** itself.
 - The anticipated date of initial operational capability.
 - The anticipated duration of operational service.
- o Specific service arrangements shall be made via memoranda of agreement. Neither this **Recommended Standard** nor any ensuing **standard** is a substitute for a memorandum of agreement.

No later than five years from its date of issuance, this **Recommended Standard** will be reviewed by the CCSDS to determine whether it should: (1) remain in effect without change; (2) be changed to reflect the impact of new technologies, new requirements, or new directions; or (3) be retired or canceled.

In those instances when a new version of a **Recommended Standard** is issued, existing CCSDS-related member standards and implementations are not negated or deemed to be non-CCSDS compatible. It is the responsibility of each member to determine when such standards or implementations are to be modified. Each member is, however, strongly encouraged to direct planning for its new standards and implementations towards the later version of the Recommended Standard.

FOREWORD

Through the process of normal evolution, it is expected that expansion, deletion, or modification of this document may occur. This Recommended Standard is therefore subject to CCSDS document management and change control procedures, which are defined in the *Organization and Processes for the Consultative Committee for Space Data Systems* (CCSDS A02.1-Y-4). Current versions of CCSDS documents are maintained at the CCSDS Web site:

<http://www.ccsds.org/>

Questions relating to the contents or status of this document should be sent to the CCSDS Secretariat at the email address indicated on page i.

At time of publication, the active Member and Observer Agencies of the CCSDS were:

Member Agencies

- Agenzia Spaziale Italiana (ASI)/Italy.
- Canadian Space Agency (CSA)/Canada.
- Centre National d’Etudes Spatiales (CNES)/France.
- China National Space Administration (CNSA)/People’s Republic of China.
- Deutsches Zentrum für Luft- und Raumfahrt (DLR)/Germany.
- European Space Agency (ESA)/Europe.
- Federal Space Agency (FSA)/Russian Federation.
- Instituto Nacional de Pesquisas Espaciais (INPE)/Brazil.
- Japan Aerospace Exploration Agency (JAXA)/Japan.
- National Aeronautics and Space Administration (NASA)/USA.
- UK Space Agency/United Kingdom.

Observer Agencies

- Austrian Space Agency (ASA)/Austria.
- Belgian Science Policy Office (BELSPO)/Belgium.
- Central Research Institute of Machine Building (TsNIIMash)/Russian Federation.
- China Satellite Launch and Tracking Control General, Beijing Institute of Tracking and Telecommunications Technology (CLTC/BITTT)/China.
- Chinese Academy of Sciences (CAS)/China.
- China Academy of Space Technology (CAST)/China.
- Commonwealth Scientific and Industrial Research Organization (CSIRO)/Australia.
- Danish National Space Center (DNSC)/Denmark.
- Departamento de Ciência e Tecnologia Aeroespacial (DCTA)/Brazil.
- Electronics and Telecommunications Research Institute (ETRI)/Korea.
- European Organization for the Exploitation of Meteorological Satellites (EUMETSAT)/Europe.
- European Telecommunications Satellite Organization (EUTELSAT)/Europe.
- Geo-Informatics and Space Technology Development Agency (GISTDA)/Thailand.
- Hellenic National Space Committee (HNSC)/Greece.
- Hellenic Space Agency (HSA)/Greece.
- Indian Space Research Organization (ISRO)/India.
- Institute of Space Research (IKI)/Russian Federation.
- Korea Aerospace Research Institute (KARI)/Korea.
- Ministry of Communications (MOC)/Israel.
- Mohammed Bin Rashid Space Centre (MBRSC)/United Arab Emirates.
- National Institute of Information and Communications Technology (NICT)/Japan.
- National Oceanic and Atmospheric Administration (NOAA)/USA.
- National Space Agency of the Republic of Kazakhstan (NSARK)/Kazakhstan.
- National Space Organization (NSPO)/Chinese Taipei.
- Naval Center for Space Technology (NCST)/USA.
- Netherlands Space Office (NSO)/The Netherlands.
- Research Institute for Particle & Nuclear Physics (KFKI)/Hungary.
- Scientific and Technological Research Council of Turkey (TUBITAK)/Turkey.
- South African National Space Agency (SANSA)/Republic of South Africa.
- Space and Upper Atmosphere Research Commission (SUPARCO)/Pakistan.
- Swedish Space Corporation (SSC)/Sweden.
- Swiss Space Office (SSO)/Switzerland.
- United States Geological Survey (USGS)/USA.

DOCUMENT CONTROL

Document	Title	Date	Status
CCSDS 131.3-B-1	CCSDS Space Link Protocols over ETSI DVB-S2 Standard, Recommended Standard, Issue 1	March 2013	Original issue, superseded
CCSDS 131.3-B-2	CCSDS Space Link Protocols over ETSI DVB-S2 Standard, Recommended Standard, Issue 2	April 2022	Current issue: <ul style="list-style-type: none"> – adds support for the Unified Space Data Link Protocol; – extends use for ground-to-space and space-to-space applications; – adds applicability of CCSDS Radio Frequency and Modulation Standard; – replaces CADU with SMTF; – changes the number of MODCOD to include the Dummy PLFrame.
EC 1	Editorial Change 1	October 2024	<ul style="list-style-type: none"> – Corrects figure and table listings in table of contents; – changes page size to A4.

NOTE – Substantive changes from the original issue are marked with change bars in the inside margin.

CONTENTS

<u>Section</u>	<u>Page</u>
1 INTRODUCTION	1-1
1.1 BACKGROUND	1-1
1.2 PURPOSE	1-1
1.3 SCOPE	1-1
1.4 APPLICABILITY	1-2
1.5 DOCUMENT STRUCTURE	1-2
1.6 NOMENCLATURE	1-3
1.7 DEFINITIONS AND CONVENTIONS	1-3
1.8 PATENTED TECHNOLOGIES	1-5
1.9 REFERENCE DOCUMENTS	1-6
2 OVERVIEW	2-1
2.1 ARCHITECTURE	2-1
2.2 SUMMARY OF FUNCTIONS	2-1
2.3 INTERNAL ORGANIZATION	2-2
3 SMTF STREAM GENERATION	3-1
3.1 OVERVIEW	3-1
3.2 INPUT CCSDS TRANSFER FRAMES	3-1
3.3 SYNCH-MARKED TRANSFER FRAME	3-1
4 DVB-S2 TRANSMISSION	4-1
4.1 OVERVIEW	4-1
4.2 DVB-S2 MODE ADAPTATION FORMAT	4-1
4.3 AVERAGE SIGNAL ENERGY	4-1
4.4 SHAPING FILTERING	4-1
5 MANAGED PARAMETERS	5-1
5.1 OVERVIEW	5-1
5.2 PERMANENT MANAGED PARAMETERS	5-1
5.3 VARIABLE MANAGED PARAMETERS	5-3
ANNEX A SERVICE DEFINITION (NORMATIVE)	A-1
ANNEX B SECURITY, SANA AND PATENT CONSIDERATIONS (INFORMATIVE)	B-1

CONTENTS (continued)

<u>Section</u>	<u>Page</u>
ANNEX C ACRONYMS AND TERMS (INFORMATIVE)	C-1
ANNEX D DVB-S2 SPECTRAL EFFICIENCIES AND MODCOD IDENTIFIERS (INFORMATIVE)	D-1
 <u>Figure</u>	
1-1 Bit Numbering Convention	1-5
2-1 Relationship with OSI Layers	2-1
2-2 Stream Format While Transmitting CCSDS Transfer Frames Using DVB-S2	2-3
 <u>Table</u>	
5-1 Permanent Managed Parameters for Transfer Frame Synchronization.....	5-2
5-2 Permanent Managed Parameters for DVB-S2 Transmission.....	5-2
5-3 Variable Managed Parameters.....	5-3

1 INTRODUCTION

1.1 BACKGROUND

The high demand in TV broadcasting has pushed the European Telecommunications Standards Institute (ETSI) to define a new satellite communication standard called Digital Video Broadcasting—Satellite—Second Generation (DVB-S2) (reference [1]). This standard is suited to high data rate transmissions, and proposes variable or adaptive coding and modulation with high power and bandwidth efficiencies.

1.2 PURPOSE

The purpose of this document is to define a recommended interface between CCSDS Space Link Protocols (references [3], [4], and [7]) and the DVB-S2 telecom standard (reference [1]), and to recommend options of the DVB-S2 standard suited to high data rate transmission applications, such as Earth Exploration Satellite Services (EESS) payload telemetry. However, this Recommended Standard may be also adopted for other high data rate applications (either space-to-ground, ground-to-space, and space-to-space) and services (e.g., the space research service), as long as compliance to CCSDS recommendations for Radio Frequency modulations in (reference [8]) is ensured.

1.3 SCOPE

The DVB-S2 standard (reference [1]) proposes advanced modulation techniques (QPSK, 8PSK, 16APSK and 32APSK) and a wide range of coding rates (from 1/4 to 9/10) with near-Shannon coding schemes (LDPC codes). This high number of modulation and coding schemes allows a wide range of possibilities to satisfy specific mission constraints.

Moreover, to maximize the system throughput, it is possible to adapt the transmitted waveform (and the useful data rate) to the variable conditions of the link. The DVB-S2 standard can actually implement Variable Coding and Modulation (VCM) mode, which adapts the transmission scheme to the channel conditions following a predetermined schedule (for example, following a dynamic link budget). When a channel is available to provide feedback (e.g., via a command link), the transmission scheme can be dynamically adjusted using the Adaptive Coding and Modulation (ACM) mode.

The use of the DVB-S2 standard for telemetry enables the use of generic Very High Scale Integrated Circuits (VHSIC) Hardware Description Language (VHDL) Intellectual Property (IP) modules for developments. The use of a widely implemented standard simplifies finding transmitting or receiving equipment to check compatibility. Finally, for the ground part, some telecom DVB-S2 receivers or Application Specific Integrated Circuits (ASICs) developed for the telecom market could be reused.

This Recommended Standard is an adaptation profile describing how to use the DVB-S2 standard to transmit CCSDS Transfer Frames. The interface between CCSDS and DVB-S2 is based on the Attached Synchronization Marker (ASM) and Synch-Marked Transfer Frame (SMTF) already introduced in reference [2].

DVB-S2 is used in this adaptation profile as a complete and self-sufficient standard, and definitions and specifications taken from DVB-S2 are applicable only in the context of this Recommended Standard. However, individual DVB-S2 functions or components (e.g., VCM/ACM, 8-PSK, and higher-order modulations) might be reused, redefined, and/or respecified by CCSDS in future Recommended Standards.

1.4 APPLICABILITY

This Recommended Standard applies to the creation of Agency standards and to data communications over space links between CCSDS Agencies in cross-support situations for applications such as EESS and SRS. This Recommended Standard includes comprehensive specification of the data formats and procedures for inter-Agency cross support. It is neither a specification of, nor a design for, real systems that may be implemented for existing or future missions.

The Recommended Standard specified in this document is to be invoked through the normal standards programs of each CCSDS Agency and is applicable to those missions for which cross support based on capabilities described in this Recommended Standard is anticipated. Where mandatory capabilities are clearly indicated in sections of this Recommended Standard, it is mandatory to implement them when this document is used as a basis for cross support. Where options are allowed or implied, implementation of these options is subject to specific bilateral cross-support agreements between the Agencies involved.

1.5 DOCUMENT STRUCTURE

Section 1 presents the background, purpose, scope, applicability, and rationale of this Recommended Standard and lists the conventions, definitions, and references used throughout the document.

Section 2 provides an overview of the system architecture.

Section 3 specifies the SMTF stream generation.

Section 4 specifies the DVB-S2 transmission of the SMTF stream.

Section 5 specifies managed parameters.

Annex A provides the service definition.

Annex B discusses security, Space Assigned Numbers Authority (SANA), and patent considerations.

Annex C lists acronyms and terms used within this document.

Annex D lists MODCOD available in the DVB-S2 standard.

1.6 NOMENCLATURE

1.6.1 NORMATIVE TEXT

The following conventions apply for the normative specifications in this Recommended Standard:

- a) the words ‘shall’ and ‘must’ imply a binding and verifiable specification;
- b) the word ‘should’ implies an optional, but desirable, specification;
- c) the word ‘may’ implies an optional specification;
- d) the words ‘is’, ‘are’, and ‘will’ imply statements of fact.

NOTE – These conventions do not imply constraints on diction in text that is clearly informative in nature.

1.6.2 INFORMATIVE TEXT

In the normative sections of this document, informative text is set off from the normative specifications either in notes or under one of the following subsection headings:

- Overview;
- Background;
- Rationale;
- Discussion.

1.7 DEFINITIONS AND CONVENTIONS

1.7.1 DEFINITIONS

1.7.1.1 Definitions from the Open System Interconnection (OSI) Basic Reference Model

This Recommended Standard makes use of a number of terms defined in reference [5]. The use of those terms in this Recommended Standard shall be understood in a generic sense, i.e., in the sense that those terms are generally applicable to any of a variety of technologies that provide for the exchange of information between real systems. Those terms are:

- a) Data Link Layer;

- b) Physical Layer;
- c) service;
- d) service data unit.

1.7.1.2 Definitions from OSI Service Definition Conventions

This Recommended Standard makes use of a number of terms defined in reference [6]. The use of those terms in this Recommended Standard shall be understood in a generic sense, i.e., in the sense that those terms are generally applicable to any of a variety of technologies that provide for the exchange of information between real systems. Those terms are:

- a) indication;
- b) primitive;
- c) request;
- d) service provider;
- e) service user.

1.7.1.3 Definition of SMTF

The SMTF is introduced in reference [2] and consists in the concatenation of an ASM and a Transfer Frame.

1.7.1.4 Definitions from ETSI DVB-S2 Standard

This Recommended Standard makes use of a number of terms defined in reference [1].

- a) DATAFIELD and DFL are defined in paragraph 5.1.5 of reference [1].
- b) BBHEADER is defined in paragraph 5.1.6 of reference [1].
- c) FECFRAME is defined in paragraph 5.3 of reference [1].
- d) PLFRAME is defined in paragraph 5.5 of reference [1].
- e) Dummy PLFRAME is defined in paragraph 5.5.1 of reference [1].
- f) PLHEADER and MODCOD are defined in paragraph 5.5.2 of reference [1].

1.7.2 CONVENTIONS

In this document, the following convention is used to identify each bit in an N -bit field. The first bit in the field to be transmitted (i.e., the most left justified when drawing a figure) is defined to be ‘Bit 0’; the following bit is defined to be ‘Bit 1’ and so on up to ‘Bit $N-1$ ’. When the field is used to express a binary value (such as a counter), the Most Significant Bit (MSB) shall be the first transmitted bit of the field, i.e., ‘Bit 0’ (see figure 1-1).

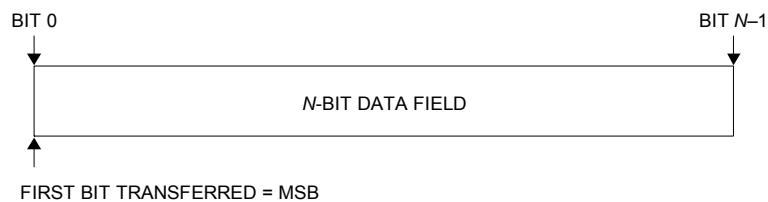

Figure 1-1: Bit Numbering Convention

In accordance with standard data-communications practice, data fields are often grouped into 8-bit ‘words’ which conform to the above convention. Throughout this Recommended Standard, such an 8-bit word is called an ‘octet’.

The numbering for octets within a data structure starts with ‘0’.

1.8 PATENTED TECHNOLOGIES

The CCSDS draws attention to the fact that it is claimed that compliance with this document may involve the use of patents.

The CCSDS takes no position concerning the evidence, validity, and scope of these patent rights.

The holders of these patent rights have assured the CCSDS that they are willing to negotiate licenses under reasonable and non-discriminatory terms and conditions with applicants throughout the world. In this respect, the statements of the holders of these patent rights are registered with CCSDS. Information can be obtained from the CCSDS Secretariat at the address indicated on page i. Contact information for the holders of these patent rights is provided in annex B.

Attention is drawn to the possibility that some of the elements of this document may be the subject of patent rights other than those identified above. The CCSDS shall not be held responsible for identifying any or all such patent rights.

1.9 REFERENCE DOCUMENTS

The following publications contain provisions which, through reference in this text, constitute provisions of this document. At the time of publication, the editions indicated were valid. All publications are subject to revision, and users of this document are encouraged to investigate the possibility of applying the most recent editions of the publications indicated below. The CCSDS Secretariat maintains a register of currently valid CCSDS publications.

- [1] *Digital Video Broadcasting (DVB); Second Generation Framing Structure, Channel Coding and Modulation Systems for Broadcasting, Interactive Services, News Gathering and Other Broadband Satellite Applications; Part 1: DVB-S2*. ETSI EN 302 307-1 V1.4.1 (2014-07). Sophia-Antipolis: ETSI, 2014.

NOTE – ETSI standards are available for free download at <https://www.etsi.org>.

- [2] *TM Synchronization and Channel Coding*. Recommendation for Space Data System Standards, CCSDS 131.0-B-3. Blue Book. Issue 3. Washington, D.C.: CCSDS, September 2017.
- [3] *TM Space Data Link Protocol*. Recommendation for Space Data System Standards, CCSDS 132.0-B-3. Blue Book. Issue 3. Washington, D.C.: CCSDS, October 2021.
- [4] *AOS Space Data Link Protocol*. Recommendation for Space Data System Standards, CCSDS 732.0-B-4. Blue Book. Issue 4. Washington, D.C.: CCSDS, October 2021.
- [5] *Information Technology—Open Systems Interconnection—Basic Reference Model: The Basic Model*. International Standard, ISO/IEC 7498-1:1994. 2nd ed. Geneva: ISO, 1994.
- [6] *Information Technology—Open Systems Interconnection—Basic Reference Model—Conventions for the Definition of OSI Services*. International Standard, ISO/IEC 10731:1994. Geneva: ISO, 1994.
- [7] *Unified Space Data Link Protocol*. Recommendation for Space Data System Standards, CCSDS 732.1-B-2. Blue Book. Issue 2. Washington, D.C.: CCSDS, October 2021.
- [8] *Radio Frequency and Modulation Systems—Part 1: Earth Stations and Spacecraft*. Issue 31. Recommendation for Space Data System Standards (Blue Book), CCSDS 401.0-B-32. Washington, D.C.: CCSDS, October 2021.

2 OVERVIEW

2.1 ARCHITECTURE

Figure 2-1 illustrates the relationship of this Recommended Standard to the Open Systems Interconnection reference model (reference [5]). Two sublayers of the Data Link Layer are defined for CCSDS space link protocols. The TM, AOS, and Unified Space Data Link Protocols specified in references [3], [4], and [7], respectively, correspond to the Data Link Protocol Sublayer, and provide functions for transferring data using the protocol data unit called the Transfer Frame. The Synchronization and Channel Coding Sublayer provides methods of synchronization and channel coding for transferring Transfer Frames over a space link while the Physical Layer provides the RF and modulation methods for transferring a stream of bits over a space link in a single direction.

This Recommended Standard covers the functions of both the Synchronization and Channel Coding Sublayer and the Physical Layer, the latter for what concerns the modulation schemes. Reference [8] covers additional features of the Physical Layer like frequency bands and polarizations that are not described or referenced here.

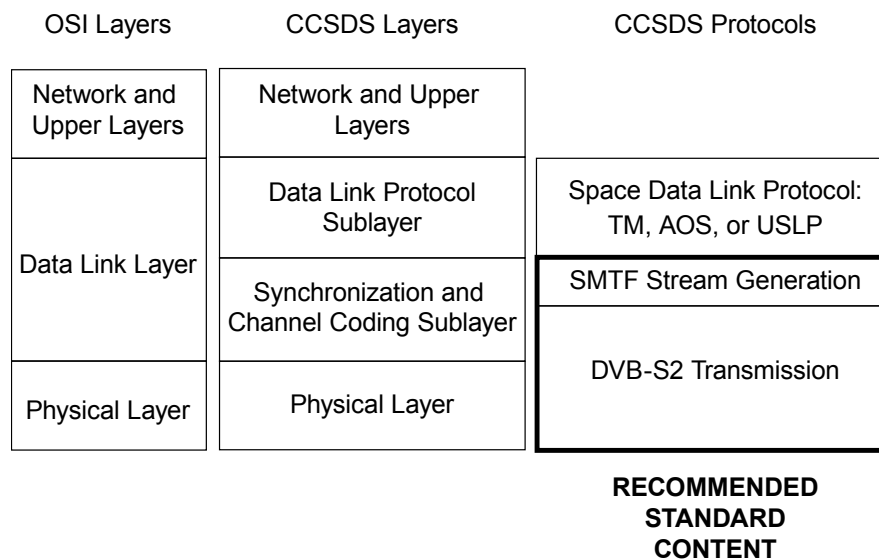

Figure 2-1: Relationship with OSI Layers

2.2 SUMMARY OF FUNCTIONS

2.2.1 GENERAL

This Recommended Standard provides the following functions for transferring Transfer Frames via a stream of bits over a space link:

- a) pseudo-randomizing;
- b) error correction coding and modulation;

- c) Transfer Frame synchronization;
- d) Transfer Frame validation.

2.2.2 PSEUDO-RANDOMIZING

Pseudo-randomizing is specified in the DVB-S2 standard. No other pseudo-randomizing of Transfer Frames is required.

2.2.3 ERROR CORRECTION CODING AND MODULATION

Error correction coding and modulation are specified in the DVB-S2 standard. No other error correction coding of Transfer Frames is required.

2.2.4 TRANSFER FRAME SYNCHRONIZATION

This Recommended Standard specifies an Attached Sync Marker (ASM) for synchronizing Transfer Frames at the receiver.

2.2.5 TRANSFER FRAME VALIDATION

After decoding is performed, the upper layers at the receiving end also need to know whether or not each decoded Transfer Frame can be used as a valid data unit; i.e., an indication of the quality of the received frame is needed. This function is called Frame Validation. In this Recommended Standard, the Frame Error Control Field defined in references [3], [4], and [7] is used for Transfer Frame Validation at the receiver.

2.3 INTERNAL ORGANIZATION

2.3.1 SENDING END

2.3.1.1 General

Figure 2-2 illustrates the frame structures and stream formats at different stages of processing for the sending end.

2.3.1.2 SMTF Stream Generation

This Recommended Standard specifies a method to generate a data stream including CCSDS Transfer Frames received from the layer above by embedding each CCSDS Transfer Frame into a SMTF. This method also allows CCSDS Transfer Frame synchronization at the receiver by using an ASM. ASM and SMTF are defined in reference [2].

2.3.1.3 DVB-S2 Transmission

This Recommended Standard specifies the DVB-S2 options to transmit the SMTF stream.

DVB-S2 functions are not detailed here and the reader must refer to reference [1].

Some important characteristics of the DVB-S2 transmission, as used in this Recommended Standard, are summarized here:

- DVB-S2 transmission is frame oriented: a continuous binary stream to be transmitted is sliced into blocks of Data Field Length (DFL) bits, with DFL depending on the coding rate and the FECFRAME size; Physical Layer frames (PLFRAMEs) are then transmitted continuously on the RF link.
- For a given channel symbol rate, the input (SMTF stream) data rate depends on the modulation, the coding rate, the FECFRAME size and the pilot insertion status; the input data rate can be derived from the channel symbol rate using the table in annex D.
- A combination of a modulation and a coding rate is called a MODCOD as per DVB-S2 terminology.

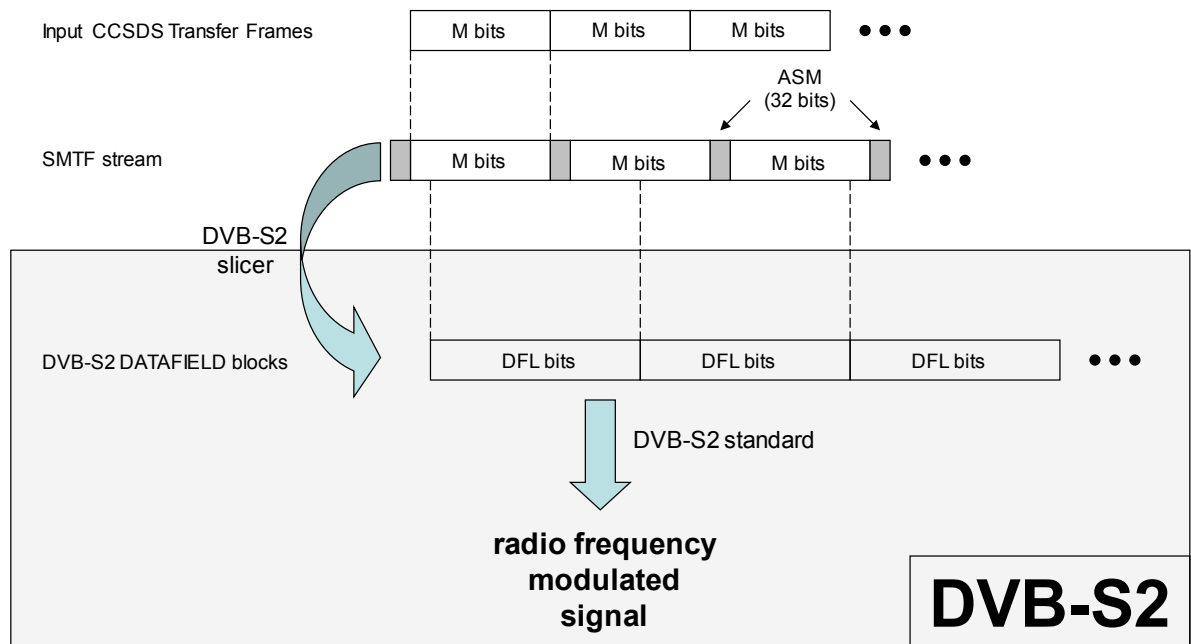

Figure 2-2: Stream Format While Transmitting CCSDS Transfer Frames Using DVB-S2

2.3.2 RECEIVING END

At the receiving end:

- the DVB-S2 demodulator accepts a radio frequency modulated signal and delivers a SMTF stream;
- Transfer Frame synchronization allows recovery of CCSDS Transfer Frames in the SMTF stream for delivery of those frames to the Data Link Protocol Sublayer.

3 SMTF STREAM GENERATION

3.1 OVERVIEW

CCSDS Transfer Frame synchronization is necessary at the receiver. Consequently, an ASM is introduced before transmission. Error correction coding and pseudo-randomization are performed at the DVB-S2 transmission level.

3.2 INPUT CCSDS TRANSFER FRAMES

3.2.1 Input Transfer Frames shall be either TM Transfer Frames as specified in reference [3], AOS Transfer Frames as specified in reference [4], or USLP Transfer Frame as specified in reference [7].

NOTE – Per A2.1 only fixed-length frames are accepted when using USLP Transfer Frames.

3.2.2 The Transfer Frames length shall vary between the following minimum and maximum values: 223 octets (1784 bits) and 65536 octets (524288 bits).

3.2.3 Error correction coding and pseudo-randomization shall be performed **only** at the DVB-S2 transmission level.

3.3 SYNCH-MARKED TRANSFER FRAME

3.3.1 For each Transfer Frame, the system shall construct a SMTF containing the ASM and the Transfer Frame.

3.3.2 The ASM shall be the 32-bit (4-octet) marker with value 1ACFFC1D in hex defined in reference [2].

NOTE – In this book, the SMTF stream consists of a stream of fixed-length Transfer Frames with each Transfer Frame immediately preceded by an ASM. The ASM attached to a Transfer Frame immediately follows the end of the previous Transfer Frame.

4 DVB-S2 TRANSMISSION

4.1 OVERVIEW

In this section, main characteristics of the DVB-S2 transmission of the SMTF stream are specified. Definitions and vocabulary of the DVB-S2 standard (reference [1]) are used.

4.2 DVB-S2 MODE ADAPTATION FORMAT

4.2.1 The RF signal shall conform to the DVB-S2 standard (reference [1]).

4.2.2 The SMTF stream shall be transmitted using the single input continuous Generic Stream (GS) mode adaptation format of the DVB-S2 standard (paragraph 5.1 of reference [1]).

NOTES

- 1 No particular alignment between the Transfer Frames of the SMTF stream and the DVB-S2 DATAFIELD is needed.
- 2 Following table 3 of reference [1], the first 3 bits of the BBHEADER are consequently '011' ('01': generic continuous stream, '1': single input stream).

4.2.3 The DVB-S2 slicer shall allocate a number of input bits equal to the maximum DVB-S2 DATAFIELD capacity.

NOTES

- 1 In other words, padding (paragraph 5.2.1 of reference [1]) is not used.
- 2 This maximum DATAFIELD capacity is equal to $K_{\text{bch}} - 80$ bits and depends on the considered coding rate and FECFRAME size.
- 3 In the DVB-S2 standard, the channel symbol rate does not change during a transmission; consequently, the required input (SMTF stream) data rate changes whenever the MODCOD changes during a transmission.
- 4 When the current MODCOD is modified during transmission using VCM or ACM, the DVB-S2 slicer applies the change without discarding or truncating or impairing the SMTF stream, according to the DVB-S2 standard.

4.3 AVERAGE SIGNAL ENERGY

4.3.1 The average channel symbol energy E shall be equal to 1 as defined in paragraphs 5.4.3 and 5.4.4 of reference [1].

4.4 SHAPING FILTERING

4.4.1 The power spectrum density mask in annex A of reference [1] shall not be applied to the transmitted signal in this Recommended Standard.

5 MANAGED PARAMETERS

5.1 OVERVIEW

5.1.1 Some parameters associated with coding, synchronization, and modulation are handled by management rather than by inline communications protocol. The managed parameters are generally those which tend to be static for long periods of time, and whose change generally signifies a major reconfiguration of the modulation, synchronization, and channel coding systems associated with a particular mission, i.e., parameters that are fixed within a mission phase. However, as mentioned in annex A, the coding and modulation scheme defined in this book also supports parameters that can be changed from one time interval to the next, within a sequence of time intervals in a mission phase. These two types are referenced in this section respectively as Permanent Managed Parameters and Variable Managed Parameters.

5.1.2 Through the use of a management system, management conveys the required information to the coding, synchronization, and modulation systems.

5.1.3 In this section, the managed parameters used by coding, synchronization and modulation systems are listed. These parameters are defined in an abstract sense and are not intended to imply any particular implementation of a management system.

5.2 PERMANENT MANAGED PARAMETERS

5.2.1 GENERAL

5.2.1.1 All the managed parameters specified in this section shall be fixed for all Transfer Frames on a Physical Channel during a given Mission Phase.

5.2.1.2 The Frame Error Control Field defined in reference [3], reference [4], or reference [7] shall be present.

NOTE – The Frame Error Control Field is used for Frame Validation as mentioned in 2.2.5.

5.2.2 MANAGED PARAMETERS FOR TRANSFER FRAME SYNCHRONIZATION

The managed parameters for Transfer Frame Synchronization shall be those specified in table 5-1.

Table 5-1: Permanent Managed Parameters for Transfer Frame Synchronization

Managed Parameter	Allowed Values
Transfer Frame Length (octets)	Integer: 223 to 65536

5.2.3 MANAGED PARAMETERS FOR DVB-S2 TRANSMISSION

The managed parameters for DVB-S2 transmission shall be those specified in table 5-2.

NOTE – MODCOD, FECFRAME size and pilot insertion status are variable managed parameters, and are indicated with an asterisk in table 5-2.

Table 5-2: Permanent Managed Parameters for DVB-S2 Transmission

Managed Parameter	Allowed Values
Transmission mode	CCM, VCM, or ACM
Baseband pulse shaping roll-off factor	0.2, 0.25, or 0.35
Dummy PLFRAME utilization	YES or NO
Scrambling code number n	Integer: 0 to 262141 (see paragraph 5.5.4 of reference [1])
Number of MODCOD* supported during a given mission phase	Integer: 1 to 29 (For MODCOD coding, see table 12 paragraph 5.5.2.2 of reference [1].)
List of MODCOD* supported during a given mission phase	List of integers (dimension = 'Number of MODCOD supported during a given mission phase'). Each integer of the list is in the range 0 to 28 and corresponds to a supported MODCOD. (For MODCOD coding, see table 12 paragraph 5.5.2.2 of reference [1].)
Supported FECFRAME size*	Short, Normal or both
Supported pilot insertion status*	ON, OFF or both

5.3 VARIABLE MANAGED PARAMETERS

The managed parameters specified in table 5-3 shall be fixed on a Physical Channel within one interval of a given Mission Phase.

Table 5-3: Variable Managed Parameters

Managed Parameter	Allowed Values
Current MODCOD	Integer: 0 to 28 (For MODCOD coding, see table 12 paragraph 5.5.2.2 of reference [1].)
Current FECFRAME size	Short or Normal
Current pilot insertion status	ON or OFF

NOTE – These variable managed parameters are indicated in the PLHEADER of the transmitted signal; it is consequently not needed to provide them to the receiver working in VCM/ACM mode.

ANNEX A

SERVICE DEFINITION

(NORMATIVE)

A1 OVERVIEW

A1.1 BACKGROUND

This annex provides service definition in the form of primitives, which present an abstract model of the logical exchange of data and control information between the service provider and the service user. The definitions of primitives are independent of specific implementation approaches.

The parameters of the primitives are specified in an abstract sense and specify the information to be made available to the user of the primitives. The way in which a specific implementation makes this information available is not constrained by this specification. In addition to the parameters specified in this annex, an implementation can provide other parameters to the service user (e.g., parameters for controlling the service, monitoring performance, facilitating diagnosis, and so on).

A2 OVERVIEW OF THE SERVICE

A2.1 The present ‘CCSDS Space Link Protocols over ETSI DVB-S2’ Recommended Standard provides unidirectional (one way) transfer of a sequence of fixed-length TM, AOS, or USLP Transfer Frames at constant frame rate over a Physical Channel across a space link, with optional error detection/correction.

A2.2 The value of the constant frame rate can be changed from one-time interval to the next, within a sequence of time intervals in a mission phase. There can be multiple time intervals within a mission phase. This annex does not specify the method for synchronizing the data exchange between the service user and the service provider when there is a change of frame rate: the synchronization is considered to be part of system management and is out of the scope of this annex.

A2.3 Only one user can use this service on a Physical Channel, and Transfer Frames from different users are not multiplexed together within one Physical Channel.

A3 SERVICE PARAMETERS

A3.1 FRAME

A3.1.1 The Frame parameter is the service data unit of this service and shall be either a TM Transfer Frame defined in reference [3], an AOS Transfer Frame defined in reference [4], or a USLP Transfer Frame defined in reference [7].

A3.1.2 The length of any Transfer Frame transferred on a Physical Channel is established by management.

A3.2 QUALITY INDICATOR

The Quality Indicator parameter shall be used to notify the user at the receiving end of the service that there is an uncorrectable error in the received Transfer Frame.

A3.3 SEQUENCE INDICATOR

The Sequence Indicator parameter shall be used to notify the user at the receiving end of the service that one or more Transfer Frames of the Physical Channel have been lost as the result of a loss of frame synchronization.

A4 SERVICE PRIMITIVES

A4.1 GENERAL

A4.1.1 The service primitives associated with this service are:

- a) ChannelAccess.request;
- b) ChannelAccess.indication.

A4.1.2 The ChannelAccess.request primitive shall be passed from the service user at the sending end to the service provider to request that a Frame be transferred through the Physical Channel to the user at the receiving end.

A4.1.3 The ChannelAccess.indication shall be passed from the service provider to the service user at the receiving end to deliver a Frame.

A4.2 ChannelAccess.request

A4.2.1 Function

The ChannelAccess.request primitive is the service request primitive for this service.

A4.2.2 Semantics

The ChannelAccess.request primitive shall provide a parameter as follows:

ChannelAccess.request (Frame)

A4.2.3 When Generated

The ChannelAccess.request primitive shall be passed to the service provider to request it to process and send the Frame.

A4.2.4 Effect On Receipt

Receipt of the ChannelAccess.request primitive shall cause the service provider to perform the functions described in 2.2 and to transfer the resulting channel symbols.

A4.3 ChannelAccess.indication

A4.3.1 Function

The ChannelAccess.indication primitive is the service indication primitive for this service.

A4.3.2 Semantics

The ChannelAccess.indication primitive shall provide parameters as follows:

ChannelAccess.indication (Frame,
Quality Indicator,
Sequence Indicator)

A4.3.3 When Generated

The ChannelAccess.indication primitive shall be passed from the service provider to the service user at the receiving end to deliver a Frame.

A4.3.4 Effect On Receipt

The effect of receipt of the ChannelAccess.indication primitive by the service user is undefined.

ANNEX B

SECURITY, SANA AND PATENT CONSIDERATIONS

(INFORMATIVE)

B1 SECURITY CONSIDERATIONS

B1.1 SECURITY BACKGROUND

It is assumed that security is provided by encryption, authentication methods, and access control to be performed at higher layers (application and/or transport layers and/or data link layer). Mission and service providers are expected to select from recommended security methods, suitable to the specific application profile. Specification of these security methods and other security provisions is outside the scope of this Recommended Standard. The modulation, synchronization, and coding layers have the objective of delivering data with the minimum possible amount of residual errors. There is an extremely low probability of undetected errors that may escape the scrutiny performed during reception with the recommended DVB-S2 standard. If some extra performances are expected in terms of probability of undetected errors, the CRC code of the CCSDS Transfer Frame must be used with the data in order to insure that residual errors are detected and the frame flagged. These errors may affect the encryption process in unpredictable ways, possibly affecting the decryption stage and producing data loss, but will not compromise the security of the data.

B1.2 SECURITY CONCERNS WITH RESPECT TO THE CCSDS DOCUMENT

Security concerns in the areas of data privacy, authentication, access to resources control, availability of resources, and auditing are to be addressed in higher layers and are not related to this Recommended Standard. The modulation, synchronization, and coding layers do not affect the proper functioning of methods used to achieve such protection at higher layers, except for undetected errors, as explained above.

Concerning the data integrity, the physical integrity of data bits is protected from channel errors by the modulation, synchronization, and coding systems specified in the DVB-S2 Standard. In case of congestion or disruption of the link, the modulation, synchronization, and coding layers described in this Recommended Standard based on DVB-S2 provide methods for frame resynchronization.

B1.3 POTENTIAL THREATS AND ATTACK SCENARIOS

An eavesdropper can receive and decode the codewords insofar as the proposed standard is publicly available and widely used in the Digital Video and Data Broadcasting community, but will not be able to get to the user data if proper encryption is performed at a higher layer.

An interferer could affect the performance of the demodulator, degrading then the receive signal-to-noise ratio by an in-band signal (pure carrier, modulated bursts, radar, or ‘chirp’ signals, etc.) and cause data losses. Another type of interferer could send some properly modulated and also properly encoded data and could then produce a congestion of the receiver with unwanted data, but such data would be rejected by authentication if implemented at a higher layer. Such interference or jamming must be dealt with at the Physical Layer and through proper spectrum regulatory entities and/or anti-jamming modulation techniques, which are outside the scope of the present Recommended Standard.

B1.4 CONSEQUENCES OF NOT APPLYING SECURITY TO THE TECHNOLOGY

There are no specific security measures prescribed for the demodulation, synchronization, and coding layers. Therefore, consequences of not applying security are only imputable to the lack of proper security measures in upper layers. Residual undetected errors may produce additional data loss when the link carries encrypted data.

B2 SANA CONSIDERATIONS

The recommendations of this document do not require any action from SANA.

B3 PATENT CONSIDERATIONS

Implementers of this Recommended Standard should be aware that DVB-S2 is covered by a set of patents for which a global license can be obtained from:

S2 Licensing
Attention: John T. Whelan
135 West Dares Beach Road, Suite 204
Prince Frederick, Maryland 20678
United States of America
Telephone: 410-535-6554
Facsimile: 410-535-6077
E-mail: jwhelan@S2licensing.com

ANNEX C

ACRONYMS AND TERMS

(INFORMATIVE)

32APSK	32-ary amplitude and phase shift keying
16APSK	16-ary amplitude and phase shift keying
8PSK	8-ary phase shift keying
ACM	adaptive coding and modulation
AOS	Advanced Orbiting Systems
ASIC	application specific integrated circuit
ASM	attached synchronization marker
BB	baseband
BBFRAME	baseband frame in the DVB-S2 standard
BBHEADER	header of BBFRAME in the DVB-S2 standard
BCH	Bose-Chaudhuri-Hocquenghem
BPSK	binary phase shift keying
CCM	constant coding and modulation
CCSDS	Consultative Committee for Space Data Systems
CRC	cyclic redundancy check
DFL	data field length in the DVB-S2 standard
DVB	Digital Video Broadcasting project
DVB-S2	DVB system of second generation for satellite broadcasting
E_b/N_0	bit energy and noise power spectral density ratio
EESS	Earth Exploration Satellites Systems
E_s/N_0	channel symbol energy and noise power spectral density ratio
ETSI	European Telecommunications Standards Institute
FEC	forward error correction
FECFRAME	forward error correction in the DVB-S2 standard
FER	frame error rate
GS	generic stream
ITU	International Telecommunications Union
LDPC	low density parity check
MODCOD	modulation and coding identifier of the DVB-S2 standard
MPEG	Moving Pictures Experts Group
MSB	most significant bit
NA	not applicable
OID	only idle data
OSI	Open Systems Interconnection
PLFRAME	Physical Layer frame in the DVB-S2 standard
PLHEADER	header of the PLFRAME in the DVB-S2 standard
QPSK	quaternary phase shift keying
RF	radio frequency

SMTF	synch-marked transfer frame	█
SNR	signal power to noise power ratio	
SOF	start of frame	
SRC	square root raised cosine	
SRS	space research service	█
SYNC	synchronization octet	
TM	telemetry	
USLP	Unified Space data Link Protocol	█
VCM	variable coding and modulation	
VHDL	VHSIC Hardware Description Language	
VHSIC	very high scale integrated circuit	

ANNEX D

DVB-S2 SPECTRAL EFFICIENCIES AND MODCOD IDENTIFIERS

(INFORMATIVE)

The following spectral efficiencies consider the SMTF stream as the useful content to be transmitted. Consequently, the required bit rate at the input of the DVB-S2 transmitter is equal to the product of the selected spectral efficiency listed in the following table with the channel symbol rate used on the physical link.

MODCOD	Modulation	LDPC code identifier	spectral efficiency [bits/symbol]			
			short frame with pilots	short frame without pilots	normal frame with pilots	normal frame without pilots
0	Unmodulated	None	0	0	0	0
1	QPSK	1/4	0.3575	0.3653	0.4786	0.4902
2	QPSK	1/3	0.6155	0.6291	0.6408	0.6564
3	QPSK	2/5	0.7446	0.7609	0.7706	0.7894
4	QPSK	1/2	0.8306	0.8488	0.9653	0.9889
5	QPSK	3/5	1.1317	1.1565	1.1600	1.1883
6	QPSK	2/3	1.2607	1.2884	1.2908	1.3223
7	QPSK	3/4	1.3897	1.4203	1.4521	1.4875
8	QPSK	4/5	1.4757	1.5082	1.5494	1.5872
9	QPSK	5/6	1.5618	1.5961	1.6153	1.6547
10	QPSK	8/9	1.6908	1.7280	1.7244	1.7665
11	QPSK	9/10			1.7460	1.7886
12	8PSK	3/5	1.6920	1.7253	1.7396	1.7800
13	8PSK	2/3	1.8850	1.9220	1.9357	1.9806
14	8PSK	3/4	2.0779	2.1188	2.1775	2.2281
15	8PSK	5/6	2.3351	2.3811	2.4223	2.4786
16	8PSK	8/9	2.5280	2.5778	2.5859	2.6460
17	8PSK	9/10			2.6184	2.6792
18	16APSK	2/3	2.5052	2.5488	2.5746	2.6372
19	16APSK	3/4	2.7616	2.8097	2.8963	2.9667
20	16APSK	4/5	2.9326	2.9836	3.0905	3.1656
21	16APSK	5/6	3.1035	3.1575	3.2219	3.3002
22	16APSK	8/9	3.3599	3.4184	3.4395	3.5231
23	16APSK	9/10			3.4827	3.5673
24	32APSK	3/4	3.4192	3.4931	3.6233	3.7033
25	32APSK	4/5	3.6308	3.7093	3.8662	3.9516
26	32APSK	5/6	3.8424	3.9255	4.0306	4.1195
27	32APSK	8/9	4.1599	4.2498	4.3029	4.3979
28	32APSK	9/10			4.3569	4.4530

NOTE – The MODCOD 0 is adopted for Dummy PLFRAME as specified in paragraph 5.5.1 of reference [1].