

Recommendation for Space Data System Standards

TC SYNCHRONIZATION AND CHANNEL CODING

RECOMMENDED STANDARD

CCSDS 231.0-B-4

BLUE BOOK
July 2021

Recommendation for Space Data System Standards

TC SYNCHRONIZATION AND CHANNEL CODING

RECOMMENDED STANDARD

CCSDS 231.0-B-4

BLUE BOOK

July 2021

AUTHORITY

Issue:	Recommended Standard, Issue 4
Date:	July 2021
Location:	Washington, DC, USA

This document has been approved for publication by the Management Council of the Consultative Committee for Space Data Systems (CCSDS) and represents the consensus technical agreement of the participating CCSDS Member Agencies. The procedure for review and authorization of CCSDS documents is detailed in *Organization and Processes for the Consultative Committee for Space Data Systems* (CCSDS A02.1-Y-4), and the record of Agency participation in the authorization of this document can be obtained from the CCSDS Secretariat at the email address below.

This document is published and maintained by:

CCSDS Secretariat
National Aeronautics and Space Administration
Washington, DC, USA
Email: secretariat@mailman.ccsds.org

STATEMENT OF INTENT

The Consultative Committee for Space Data Systems (CCSDS) is an organization officially established by the management of its members. The Committee meets periodically to address data systems problems that are common to all participants, and to formulate sound technical solutions to these problems. Inasmuch as participation in the CCSDS is completely voluntary, the results of Committee actions are termed **Recommended Standards** and are not considered binding on any Agency.

This **Recommended Standard** is issued by, and represents the consensus of, the CCSDS members. Endorsement of this **Recommendation** is entirely voluntary. Endorsement, however, indicates the following understandings:

- o Whenever a member establishes a CCSDS-related **standard**, this **standard** will be in accord with the relevant **Recommended Standard**. Establishing such a **standard** does not preclude other provisions which a member may develop.
- o Whenever a member establishes a CCSDS-related **standard**, that member will provide other CCSDS members with the following information:
 - The **standard** itself.
 - The anticipated date of initial operational capability.
 - The anticipated duration of operational service.
- o Specific service arrangements shall be made via memoranda of agreement. Neither this **Recommended Standard** nor any ensuing **standard** is a substitute for a memorandum of agreement.

No later than five years from its date of issuance, this **Recommended Standard** will be reviewed by the CCSDS to determine whether it should: (1) remain in effect without change; (2) be changed to reflect the impact of new technologies, new requirements, or new directions; or (3) be retired or canceled.

In those instances when a new version of a **Recommended Standard** is issued, existing CCSDS-related member standards and implementations are not negated or deemed to be non-CCSDS compatible. It is the responsibility of each member to determine when such standards or implementations are to be modified. Each member is, however, strongly encouraged to direct planning for its new standards and implementations towards the later version of the Recommended Standard.

FOREWORD

This document is a technical Recommended Standard for use in developing synchronization and channel coding systems and has been prepared by the Consultative Committee for Space Data Systems (CCSDS). The synchronization and channel coding concept described herein is intended for missions that are cross-supported between Agencies of the CCSDS.

Attention is drawn to the possibility that some of the elements of this document may be the subject of patent rights. CCSDS has processes for identifying patent issues and for securing from the patent holder agreement that all licensing policies are reasonable and non-discriminatory. However, CCSDS does not have a patent law staff, and CCSDS shall not be held responsible for identifying any or all such patent rights.

Through the process of normal evolution, it is expected that expansion, deletion, or modification of this document may occur. This Recommended Standard is therefore subject to CCSDS document management and change control procedures, which are defined in the *Organization and Processes for the Consultative Committee for Space Data Systems* (CCSDS A02.1-Y-4). Current versions of CCSDS documents are maintained at the CCSDS Web site:

<http://www.ccsds.org/>

Questions relating to the contents or status of this document should be sent to the CCSDS Secretariat at the email address indicated on page i.

At time of publication, the active Member and Observer Agencies of the CCSDS were:

Member Agencies

- Agenzia Spaziale Italiana (ASI)/Italy.
- Canadian Space Agency (CSA)/Canada.
- Centre National d'Etudes Spatiales (CNES)/France.
- China National Space Administration (CNSA)/People's Republic of China.
- Deutsches Zentrum für Luft- und Raumfahrt (DLR)/Germany.
- European Space Agency (ESA)/Europe.
- Federal Space Agency (FSA)/Russian Federation.
- Instituto Nacional de Pesquisas Espaciais (INPE)/Brazil.
- Japan Aerospace Exploration Agency (JAXA)/Japan.
- National Aeronautics and Space Administration (NASA)/USA.
- UK Space Agency/United Kingdom.

Observer Agencies

- Austrian Space Agency (ASA)/Austria.
- Belgian Science Policy Office (BELSPO)/Belgium.
- Central Research Institute of Machine Building (TsNIIMash)/Russian Federation.
- China Satellite Launch and Tracking Control General, Beijing Institute of Tracking and Telecommunications Technology (CLTC/BITTT)/China.
- Chinese Academy of Sciences (CAS)/China.
- China Academy of Space Technology (CAST)/China.
- Commonwealth Scientific and Industrial Research Organization (CSIRO)/Australia.
- Danish National Space Center (DNSC)/Denmark.
- Departamento de Ciência e Tecnologia Aeroespacial (DCTA)/Brazil.
- Electronics and Telecommunications Research Institute (ETRI)/Korea.
- European Organization for the Exploitation of Meteorological Satellites (EUMETSAT)/Europe.
- European Telecommunications Satellite Organization (EUTELSAT)/Europe.
- Geo-Informatics and Space Technology Development Agency (GISTDA)/Thailand.
- Hellenic National Space Committee (HNSC)/Greece.
- Hellenic Space Agency (HSA)/Greece.
- Indian Space Research Organization (ISRO)/India.
- Institute of Space Research (IKI)/Russian Federation.
- Korea Aerospace Research Institute (KARI)/Korea.
- Ministry of Communications (MOC)/Israel.
- Mohammed Bin Rashid Space Centre (MBRSC)/United Arab Emirates.
- National Institute of Information and Communications Technology (NICT)/Japan.
- National Oceanic and Atmospheric Administration (NOAA)/USA.
- National Space Agency of the Republic of Kazakhstan (NSARK)/Kazakhstan.
- National Space Organization (NSPO)/Chinese Taipei.
- Naval Center for Space Technology (NCST)/USA.
- Netherlands Space Office (NSO)/The Netherlands.
- Research Institute for Particle & Nuclear Physics (KFKI)/Hungary.
- Scientific and Technological Research Council of Turkey (TUBITAK)/Turkey.
- South African National Space Agency (SANSA)/Republic of South Africa.
- Space and Upper Atmosphere Research Commission (SUPARCO)/Pakistan.
- Swedish Space Corporation (SSC)/Sweden.
- Swiss Space Office (SSO)/Switzerland.
- United States Geological Survey (USGS)/USA.

DOCUMENT CONTROL

Document	Title	Date	Status
CCSDS 231.0-B-1	TC Synchronization and Channel Coding, Issue 1	September 2003	Original issue, superseded
CCSDS 231.0-B-2	TC Synchronization and Channel Coding, Recommended Standard, Issue 2	September 2010	Issue 2, superseded
CCSDS 231.0-B-3	TC Synchronization and Channel Coding, Recommended Standard, Issue 3	September 2017	Issue 3, superseded
CCSDS 231.0-B-4	TC Synchronization and Channel Coding, Recommended Standard, Issue 4	July 2021	Current issue – clarifies procedures related to short Low-Density Parity-Check (LDPC) codes – adds support for the Unified Space Data Link Protocol (USLP)
EC 1	Editorial Change 1	October 2024	Corrects/adjusts – figure listing in table of contents; – page size to A4.

CONTENTS

<u>Section</u>	<u>Page</u>
1 INTRODUCTION	1-1
1.1 PURPOSE	1-1
1.2 SCOPE	1-1
1.3 APPLICABILITY	1-1
1.4 RATIONALE	1-2
1.5 DOCUMENT STRUCTURE	1-2
1.6 CONVENTIONS AND DEFINITIONS	1-2
1.7 REFERENCES	1-7
2 OVERVIEW	2-1
2.1 ARCHITECTURE	2-1
2.2 SUMMARY OF FUNCTIONS	2-1
2.3 INTERNAL ORGANIZATION OF SUBLAYER	2-3
3 BCH CODING	3-1
3.1 INTRODUCTION	3-1
3.2 CODEWORD FORMAT	3-1
3.3 ENCODING PROCEDURE	3-1
3.4 FILL DATA	3-2
3.5 DECODING PROCEDURE	3-3
4 LDPC CODING	4-1
4.1 OVERVIEW	4-1
4.2 SPECIFICATION	4-1
4.3 ENCODING PROCEDURE	4-2
4.4 FILL DATA	4-3
4.5 DECODING PROCEDURE	4-3
5 COMMUNICATIONS LINK TRANSMISSION UNIT	5-1
5.1 INTRODUCTION	5-1
5.2 CLTU UNIT FORMAT	5-1
5.3 CLTU RECEPTION LOGIC	5-4

CONTENTS (continued)

<u>Section</u>	<u>Page</u>
6 RANDOMIZER	6-1
6.1 OVERVIEW	6-1
6.2 RANDOMIZER DESCRIPTION	6-1
6.3 APPLICATION OF THE RANDOMIZER	6-2
7 PHYSICAL LAYER OPERATIONS PROCEDURES	7-1
7.1 INTRODUCTION.....	7-1
7.2 DATA FORMATS.....	7-1
7.3 CARRIER MODULATION MODES	7-2
7.4 PLOP-1.....	7-3
7.5 PLOP-2.....	7-4
8 MANAGED PARAMETERS	8-1
8.1 OVERVIEW OF MANAGED PARAMETERS.....	8-1
8.2 MANAGED PARAMETERS FOR BCH AND LDPC CODING.....	8-1
ANNEX A SERVICE DEFINITION (NORMATIVE)	A-1
ANNEX B SECURITY, SANA, AND PATENT CONSIDERATIONS (INFORMATIVE)	B-1
ANNEX C ABBREVIATIONS AND ACRONYMS (INFORMATIVE)	C-1
ANNEX D INFORMATIVE REFERENCES (INFORMATIVE)	D-1

Figure

1-1 Bit Numbering Convention	1-6
2-1 Relationship with OSI Layers	2-1
2-2 Internal Organization of the Sublayer at the Sending End and Interaction with the Physical Layer, When BCH Coding is Used	2-4
2-3 Internal Organization of the Sublayer at the Sending End and Interaction with the Physical Layer When LDPC Coding is Used	2-5
2-4 Internal Organization of the Sublayer at the Receiving End, When BCH Coding is Used	2-6
2-5 Internal Organization of the Sublayer at the Receiving End, When LDPC Coding is Used	2-6
3-1 BCH Codeword Format	3-1
3-2 (63,56) Modified BCH Code Generator.....	3-2
5-1 Components of the CLTU when BCH Coding Is Used	5-1

CONTENTS (continued)

<u>Figure</u>		<u>Page</u>
5-2	Components of the CLTU when LDPC Coding Is Used	5-1
5-3	CLTU Reception State Diagram (Receiving End).....	5-4
6-1	Bit Transition Generator Logic Diagram	6-2
7-1	Sequence of CMMs Composing PLOP-1	7-4
7-2	Sequence of CMMs Composing PLOP-2	7-5

Table

4-1	Generator Matrix for (n=128,k=64) LDPC Code	4-2
4-2	Generator Matrix for (n=512,k=256) LDPC Code	4-3
5-3	CLTU Reception States (Receiving End)	5-5
5-4	CLTU Reception Events (Receiving End).....	5-5
7-1	Carrier Modulation Modes	7-3
8-1	Managed Parameters for Both BCH and LDPC Codes	8-1
8-2	Additional Managed Parameters when the BCH Code Is Used.....	8-1
8-3	Additional Managed Parameters when an LDPC Codes Is Used	8-2

1 INTRODUCTION

1.1 PURPOSE

The purpose of this Recommended Standard is to specify synchronization and channel coding schemes used with the Telecommand (TC) Space Data Link Protocol (reference [1]) or the Unified Space Data Link Protocol (USLP) (reference [6]). These schemes are to be used over ground-to-space or space-to-space communications links by space missions.

1.2 SCOPE

This Recommended Standard defines synchronization and channel coding schemes in terms of:

- a) the services provided to the users of this specification;
- b) data formats; and
- c) the procedures performed to generate and process the data formats.

It does not specify:

- a) individual implementations or products;
- b) the methods or technologies required to perform the procedures; or
- c) the management activities required to configure and control the system.

1.3 APPLICABILITY

This Recommended Standard applies to the creation of Agency standards and to the future data communications over space links between CCSDS Agencies in cross-support situations. This Recommended Standard includes comprehensive specification of the data formats and procedures for inter-Agency cross support. It is neither a specification of, nor a design for, real systems that may be implemented for existing or future missions.

The Recommended Standard specified in this document is to be invoked through the normal standards programs of each CCSDS Agency, and is applicable to those missions for which cross support, based on capabilities described in this Recommended Standard, is anticipated. Where mandatory capabilities are clearly indicated in sections of this Recommended Standard, they must be implemented when this document is used as a basis for cross support. Where options are allowed or implied, implementation of these options is subject to specific bilateral cross support agreements between the Agencies involved.

1.4 RATIONALE

The CCSDS believes it is important to document the rationale underlying the recommendations chosen, so that future evaluations of proposed changes or improvements will not lose sight of previous decisions.

1.5 DOCUMENT STRUCTURE

This document is divided into eight numbered sections and four annexes:

- a) section 1 presents the purpose, scope, applicability and rationale of this Recommended Standard and lists the conventions, definitions, and references used throughout the Recommended Standard;
- b) section 2 provides an overview of synchronization and channel coding;
- c) section 3 specifies the Bose-Chaudhuri-Hocquenghem (BCH) coding;
- d) section 4 specifies Low-Density Parity-Check (LDPC) coding;
- e) section 5 specifies the Communications Link Transmission Unit (CLTU);
- f) section 6 specifies the randomizer;
- g) section 7 specifies the Physical Layer Operations Procedures (PLOPs);
- h) section 8 lists the managed parameters associated with synchronization and channel coding;
- i) annex A defines the service provided to the users;
- j) annex B discusses security, Space Assigned Numbers Authority (SANA), and patent considerations with respect to this document;
- k) annex C lists acronyms and terms used within this document;
- l) annex D provides a list of informative references.

1.6 CONVENTIONS AND DEFINITIONS

1.6.1 DEFINITIONS

1.6.1.1 Definitions from *Information Technology—Open Systems Interconnection—Basic Reference Model: The Basic Model*

This Recommended Standard makes use of a number of terms defined in reference [2]. The use of those terms in this Recommended Standard is to be understood in a generic sense; i.e., in the sense that those terms are generally applicable to any of a variety of technologies that provide for the exchange of information between real systems. Those terms are as follows:

- a) Data Link Layer;
- b) Physical Layer;
- c) service;
- d) service data unit.

1.6.1.2 Definitions from *Information Technology—Open Systems Interconnection—Basic Reference Model—Conventions for the Definition of OSI Services*

This Recommended Standard makes use of a number of terms defined in reference [3]. The use of those terms in this Recommended Standard shall be understood in a generic sense; i.e., in the sense that those terms are generally applicable to any of a variety of technologies that provide for the exchange of information between real systems. Those terms are as follows:

- a) indication;
- b) primitive;
- c) request;
- d) service provider;
- e) service user.

1.6.1.3 Terms Defined in This Recommended Standard

For the purposes of this Recommended Standard, the following definitions apply. Many other terms that pertain to specific items are defined in the appropriate sections.

Acquisition Sequence: A specific high transition density bit pattern transmitted to permit the receiving end to acquire symbol synchronization.

Bit Transition Generator, BTG: A generator that produces a specific random sequence of 255 bits to be exclusively ORed (EX-ORed) with the Transfer Frame(s) to increase the frequency of bit transitions (between ‘1’ and ‘0’). No additional bits are added by this process.

Carrier Modulation Mode, CMM: The mode of modulation determined by the data type being used to modulate the RF carrier or subcarrier.

Channel Coding Sublayer: (See **Synchronization and Channel Coding Sublayer**.)

codeword: One of the sequences in the range of the one-to-one transformation performed by an encoder. A codeword of an (n,k) block code is a sequence of n channel symbols which are produced by encoding a sequence of k information bits.

NOTE – Through issue 2 of this Recommended Standard, the term Codeblock was used to identify a ‘fixed-length data entity containing information and check bits that have been structured by an encoding algorithm’. In issue 3, this term was changed to ‘codeword’ for consistency with common usage.

Coding Sublayer: (See **Synchronization and Channel Coding Sublayer**.)

Communications Link Transmission Unit, CLTU: A Synchronization and Channel Coding Sublayer data entity which is used to synchronize and delimit the beginning of a continuum of bits consisting of a Start Sequence followed by an integral number of codewords and a Tail Sequence.

communications session: A continuous period of time during which the signal path is established for the communications channel.

decoding (hard decision): A Synchronization and Channel Coding Sublayer algorithmic process which utilizes the check bits contained in a codeword for detecting or correcting errors in the information bits. The check bits are then removed before the information bits are outputted.

decoding (soft decision): A Synchronization and Channel Coding Sublayer algorithmic process which uses quantization of the detector output into l levels for each received bit to decide upon the most likely codeword and to estimate the reliability of that decision. The check bits are then removed before the best-estimate information bits and any reliability information is outputted.

encoded data: The data contained in a codeword.

encoding: As used in this document, a Synchronization and Channel Coding Sublayer algorithmic process which adds check bits to a series of information bits to create a codeword.

event: As used in this document, an action which causes the CLTU Reception Logic to change states.

fill: Bits appended by the Synchronization and Channel Coding Sublayer to the Transfer Frame(s) to enable the data entity to exactly fit an integer number of codewords. These fill data ARE transmitted and must be removed by the sublayer above. The pattern of the Fill shall consist of a sequence of alternating ‘ones’ and ‘zeros’ starting with a ‘zero’.

Filler Bit: The last bit of the last octet of a BCH codeword to provide an overall codeword length which is an integer number of octets. The Filler Bit shall always be a zero.

Idle Sequence: A specific high transition density bit pattern transmitted during a communications session in the absence of a CLTU to maintain symbol synchronization in the channel.

octet: A contiguous string of 8 bits; an 8-bit word.

Physical Channel: A stream of bits transferred over a space link in a single direction.

Physical Layer Operations Procedure, PLOP: A specific procedure of the Physical Layer designed to activate and deactivate the physical communications channel by invoking RF carrier and modulation techniques.

pseudo-randomization: Pseudo-randomization, herein called randomization, is a bandwidth-efficient technique of algorithmically translating the data bits to insure frequent bit transitions in the communications channel.

reliable: Meeting the quality, quantity, continuity and completeness criteria specified by the communications system.

space link: A communications link between a spacecraft and its associated ground system or between two spacecraft. A space link consists of one or more Physical Channels in one or both directions.

Start Sequence: A specific bit pattern at the beginning of a CLTU having a high autocorrelation function following an Idle or Acquisition Sequence and which: a) synchronizes start of a CLTU; b) delimits start of first codeword; and c) resolves the sense of a '1' and '0' in the CLTU, if necessary.

symbol: A bit in an encoded data stream.

Synchronization and Channel Coding Sublayer: That sublayer of the Data Link Layer used by CCSDS space link protocols which uses a prescribed coding technique to reliably transfer Transfer Frames through the potentially noisy Physical Layer.

Tail Sequence: A specific data pattern which delimits the end of a CLTU.

Transfer Frame: The Protocol Data Unit (PDU) generated by the Data Link Protocol Sublayer of CCSDS space link protocols.

NOTES

- 1 In this document, it refers exclusively either to a TC Transfer Frame or to a USLP Transfer Frame.
- 2 The service data unit of the Coding & Synchronization sublayer consists of either one or more TC Transfer Frames or a single USLP Transfer Frame .

1.6.2 CONVENTIONS

In this document, the following convention is used to identify each bit in an N-bit field. The first bit in the field to be transmitted (i.e., the most left justified when drawing a figure) is defined to be 'Bit 0'; the following bit is defined to be 'Bit 1' and so on up to 'Bit N-1'.

When the field is used to express a binary value (such as a counter), the Most Significant Bit (MSB) shall be the first transmitted bit of the field, i.e., 'Bit 0' (see figure 1-1).

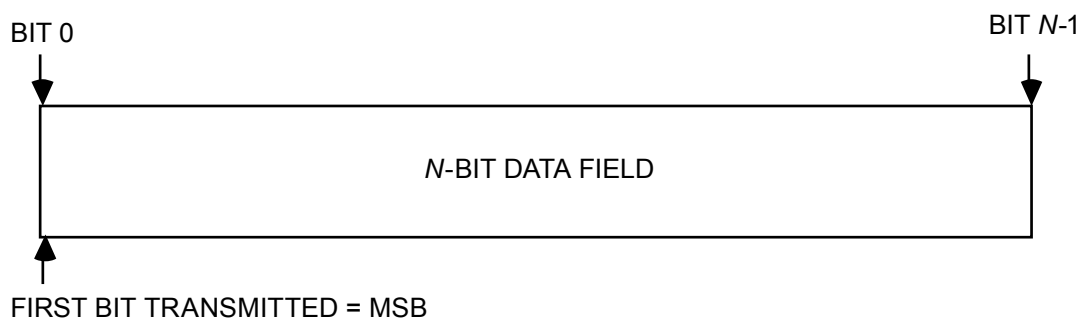

Figure 1-1: Bit Numbering Convention

In accordance with standard data-communications practice, data fields are often grouped into 8-bit 'words' which conform to the above convention. Throughout this Recommended Standard, such an 8-bit word is called an 'octet'. The numbering for octets within a data structure starts with 0. By CCSDS convention, all 'spare' bits shall be permanently set to '0'.

1.6.3 NOMENCLATURE

1.6.3.1 Normative Text

The following conventions apply for the normative specifications in this Recommended Standard:

- a) the words 'shall' and 'must' imply a binding and verifiable specification;
- b) the word 'should' implies an optional, but desirable, specification;
- c) the word 'may' implies an optional specification;
- d) the words 'is', 'are', and 'will' imply statements of fact.

NOTE – These conventions do not imply constraints on diction in text that is clearly informative in nature.

1.6.3.2 Informative Text

In the normative sections of this document, informative text is set off from the normative specifications either in notes or under one of the following subsection headings:

- Overview;
- Background;
- Rationale;
- Discussion.

1.7 REFERENCES

The following documents contain provisions which, through reference in this text, constitute provisions of this Recommended Standard. At the time of publication, the editions indicated were valid. All documents are subject to revision, and users of this Recommended Standard are encouraged to investigate the possibility of applying the most recent editions of the documents indicated below. The CCSDS Secretariat maintains a register of currently valid CCSDS Recommended Standards.

- [1] *TC Space Data Link Protocol*. Issue 3. Recommendation for Space Data System Standards (Blue Book), CCSDS 232.0-B-3. Washington, D.C.: CCSDS, September 2015.
- [2] *Information Technology—Open Systems Interconnection—Basic Reference Model: The Basic Model*. 2nd ed. International Standard, ISO/IEC 7498-1:1994. Geneva: ISO, 1994.
- [3] *Information Technology—Open Systems Interconnection—Basic Reference Model—Conventions for the Definition of OSI Services*. International Standard, ISO/IEC 10731:1994. Geneva: ISO, 1994.
- [4] *Radio Frequency and Modulation Systems—Part 1: Earth Stations and Spacecraft*. Issue 30. Recommendation for Space Data System Standards (Blue Book), CCSDS 401.0-B-30. Washington, D.C.: CCSDS, February 2020.
- [5] *Space Link Extension—Forward CLTU Service Specification*. Issue 4. Recommendation for Space Data System Standards (Blue Book), CCSDS 912.1-B-4. Washington, D.C.: CCSDS, August 2016.
- [6] *Unified Space Data Link Protocol*. Issue 1. Recommendation for Space Data System Standards (Blue Book), CCSDS 732.1-B-1. Washington, D.C.: CCSDS, October 2018.

NOTE – Informative references are listed in annex D.

2 OVERVIEW

2.1 ARCHITECTURE

Figure 2-1 illustrates the relationship of this Recommended Standard to the Open Systems Interconnection (OSI) reference model (reference [2]). Two sublayers of the Data Link Layer are defined for CCSDS space link protocols. The TC Space Data Link Protocol specified in reference [1] and the Unified Space Data Link Protocol specified in reference [6] correspond to the Data Link Protocol Sublayer and provide functions for transferring data using the protocol data unit called the Transfer Frame. The Synchronization and Channel Coding Sublayer provides additional functions necessary for transferring Transfer Frames over a space link. These functions are error-control coding/decoding, codeword delimiting/synchronizing, and bit transition generation/removal.

The Physical Layer provides the RF channel and the techniques required to operate it as, e.g., modulation, demodulation, and bit/symbol synchronization. This Recommended Standard includes also the Physical Layer Operations Procedures (PLOP), performed in the Physical Layer, that are used to transmit CLTUs specified in this document. The other specifications of the Physical Layer are contained in reference [4].

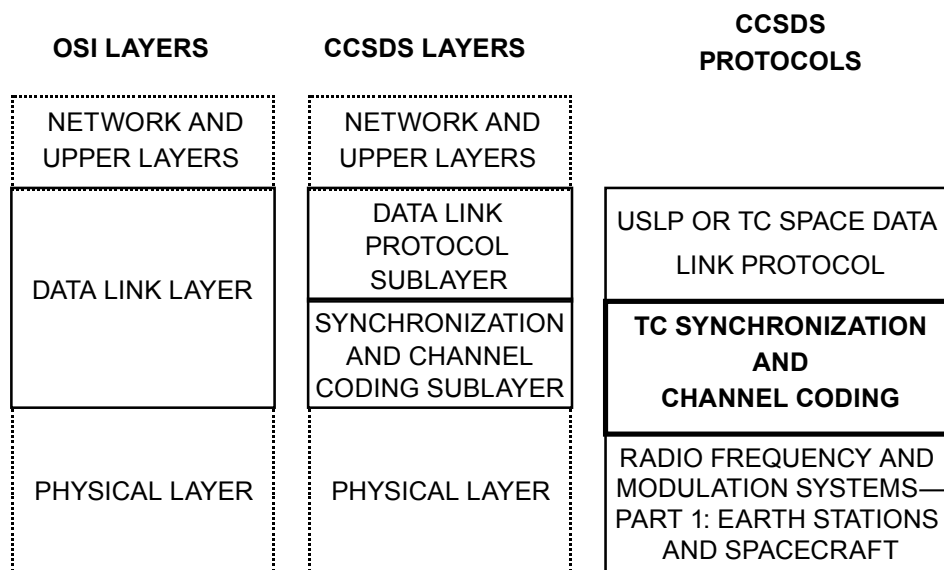

Figure 2-1: Relationship with OSI Layers

2.2 SUMMARY OF FUNCTIONS

2.2.1 FUNCTIONS

The Synchronization and Channel Coding Sublayer provides the following four functions for transferring Transfer Frames over a space link:

- a) error-control coding;

- b) synchronization;
- c) pseudo-randomizing (optional); and
- d) repeated transmissions (optional).

2.2.2 ERROR-CONTROL CODING

This Recommended Standard specifies two error-control coding methods. One uses a modified BCH code as described in section 3; the other uses LDPC codes as described in section 4.

The modified BCH code specified in this Recommended Standard may be decoded either in an error-detecting mode or in an error-correcting mode, depending on mission requirements. The LDPC codes are typically decoded from soft symbols and operate at a lower Signal to Noise Ratio (SNR). The Frame Error Control Field (FECF) defined in reference [1] or [6] may be used to reduce the probability of undetected errors, particularly when the modified BCH code is chosen and is decoded in an error-correcting mode.

NOTE – In this Recommended Standard, the characteristics of the codes are specified only to the extent necessary to ensure interoperability and cross-support. The specification does not attempt to quantify the relative coding gain or the merits of each approach discussed, nor the design requirements for encoders or decoders.

2.2.3 SYNCHRONIZATION

This Recommended Standard specifies a method for synchronizing codewords using a data unit called the Communications Link Transmission Unit (CLTU), which consists of a Start Sequence, BCH or LDPC codewords, and a Tail Sequence (optional for LDPC). This is described in section 5.

The Start Sequence of the CLTU may also be used for resolution of data ambiguity (sense of ‘1’ and ‘0’) if data ambiguity is not resolved by the modulation method used in the Physical Layer.

This Recommended Standard also specifies a procedure called the Physical Layer Operations Procedure (PLOP) for activating and deactivating the physical communications channel so that the Physical Layer of the receiving end can achieve and maintain bit synchronization.

NOTE – Although PLOP belongs to the Physical Layer, it is included in this Recommended Standard because it must be used to transmit CLTUs specified in this document. The other specifications of the Physical Layer are contained in reference [4].

2.2.4 PSEUDO-RANDOMIZING

This Recommended Standard specifies an optional randomizer to improve bit transition density as an aid to bit synchronization. This is described in section 6.

NOTE – For brevity, the word ‘random’ is used in place of ‘pseudo-random’ throughout this document. See annex C.

2.2.5 REPEATED TRANSMISSIONS

This Recommended Standard specifies an option for repeated transmissions of Transfer Frames. Annex A contains the service definition for the user in a higher sublayer to request data transfer, including an optional Repetitions parameter for repeated transmissions. This Recommended Standard does not specify how the repeated transmissions are performed within the Synchronization and Channel Coding Sublayer. Availability of the repeated transmissions option is in accordance with parameters set by management.

2.3 INTERNAL ORGANIZATION OF SUBLAYER

2.3.1 SENDING END

Figures 2-2 and 2-3 show the internal organization of the Synchronization and Channel Coding Sublayer of the sending end together with the Physical Layer. These figures identify functions performed by the sublayer and by the Physical Layer and show logical relationships among these functions. The figures are not intended to imply any hardware or software configuration in a real system.

At the sending end, the Synchronization and Channel Coding Sublayer accepts Transfer Frames from the Data Link Protocol Sublayer (see figure 2-1), performs functions selected for the mission, and delivers CLTUs to the Physical Layer. If necessary, fill data are added to complete the integral number of codewords. The Physical Layer transmits CLTUs using the PLOP.

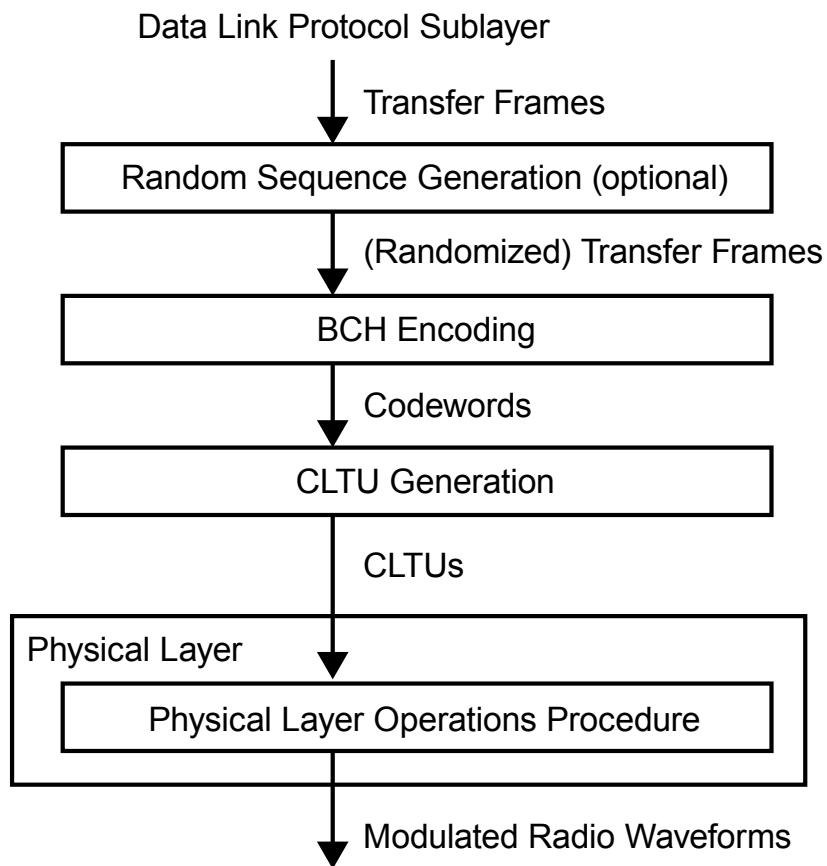

Figure 2-2: Internal Organization of the Sublayer at the Sending End and Interaction with the Physical Layer, When BCH Coding is Used

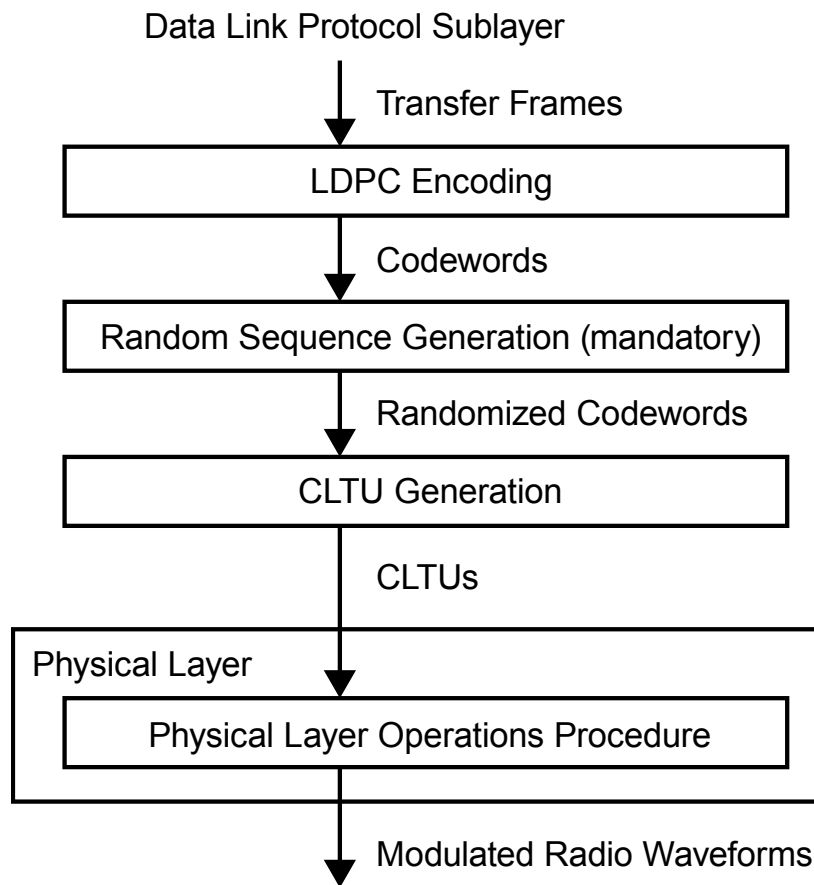

Figure 2-3: Internal Organization of the Sublayer at the Sending End and Interaction with the Physical Layer When LDPC Coding is Used

2.3.2 RECEIVING END

Figures 2-4 and 2-5 show the internal organization of the Synchronization and Channel Coding Sublayer of the receiving end. These figures identify functions performed by the sublayer and show logical relationships among these functions. The figures are not intended to imply any hardware or software configuration in a real system.

At the receiving end, the Synchronization and Channel Coding Sublayer accepts streams of channel symbols together with information on the state of the physical communications channel from the Physical Layer, performs functions selected for the mission, and delivers Transfer Frames (possibly incomplete or with fill data) to the Data Link Protocol Sublayer.

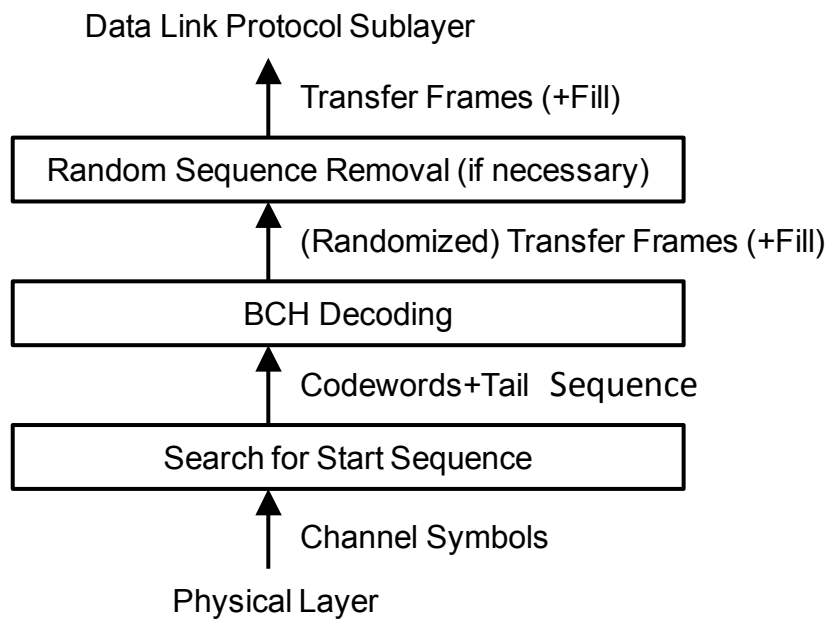

Figure 2-4: Internal Organization of the Sublayer at the Receiving End, When BCH Coding is Used

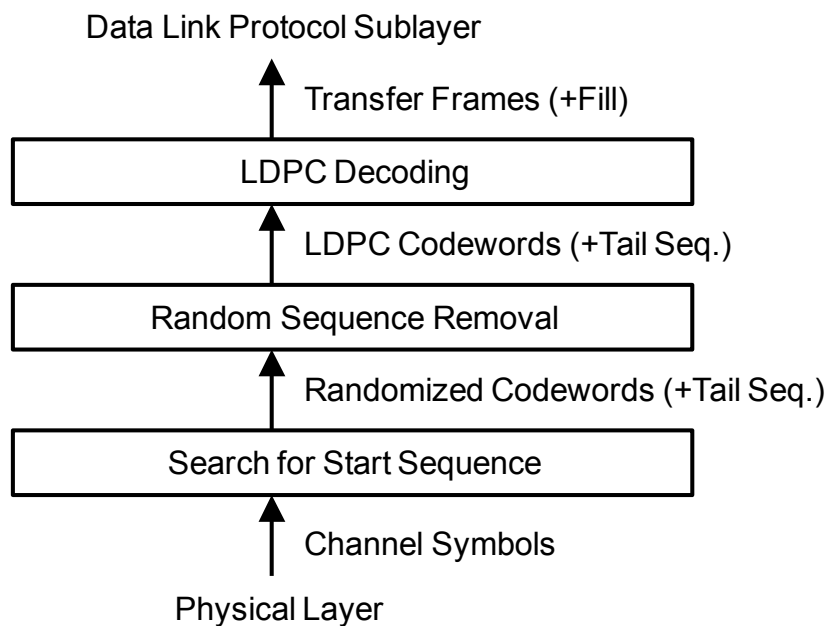

Figure 2-5: Internal Organization of the Sublayer at the Receiving End, When LDPC Coding is Used

3 BCH CODING

3.1 INTRODUCTION

The Synchronization and Channel Coding Sublayer establishes the reliable, error-controlled data channel through which user data bits may be transferred. The data are encoded to reduce the effects of noise in the Physical Layer on the user data. A modified Bose-Chaudhuri-Hocquenghem (BCH) code has been chosen to provide this protection.

3.2 CODEWORD FORMAT

3.2.1 The BCH codeword format is a fixed-length data entity shown in figure 3-1. The codeword is formulated using a systematic coding technique which contains 56 information bits in the leading octets, and the error control bits in the last octet. The BCH codeword contains an integer number of octets with an overall length of 8 octets (64 bits).

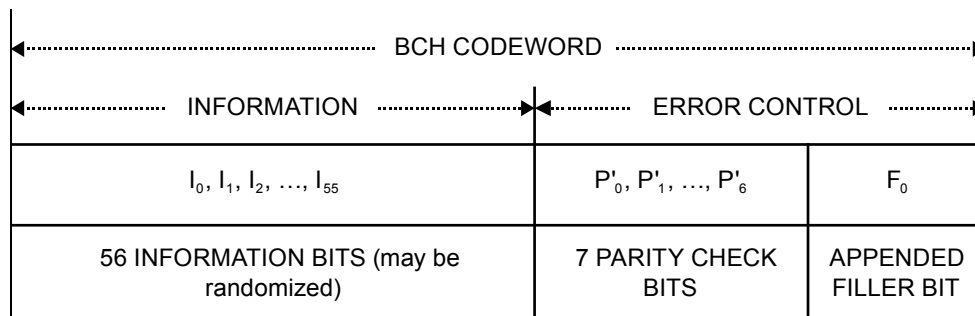

Figure 3-1: BCH Codeword Format

3.2.2 The COMPLEMENTS of the seven parity check bits, P_0 through P_6 , are located in the first seven bits of the last octet of the BCH codeword. The complements are used to aid in maintaining bit synchronization and detection of bit slippage. The encoding procedure for generating these parity bits is described in 3.3.

3.2.3 The last bit of the last octet, F_0 , is a Filler Bit appended to provide an overall codeword length which is an integer number of octets. This Filler Bit shall always be a zero.

3.3 ENCODING PROCEDURE

3.3.1 A systematic block coding procedure shall be used which always generates 7 parity check bits per codeword and which shall always be computed from 56 information bits. The parity check bits are then COMPLEMENTED and placed into the codeword as shown in figure 3-1.

3.3.2 The code used is a (63,56) modified Bose-Chaudhuri-Hocquenghem (BCH) code which uses the following generator polynomial to produce the seven parity bits:

$$g(x) = x^7 + x^6 + x^2 + 1$$

NOTE – The code generator implementation is shown in figure 3-2. The shift registers are initialized to zero. The ganged switch is in position 1 while the 56 information bits are being transmitted, in position 2 for the seven parity bits, and in position 3 for the appended Filler Bit.

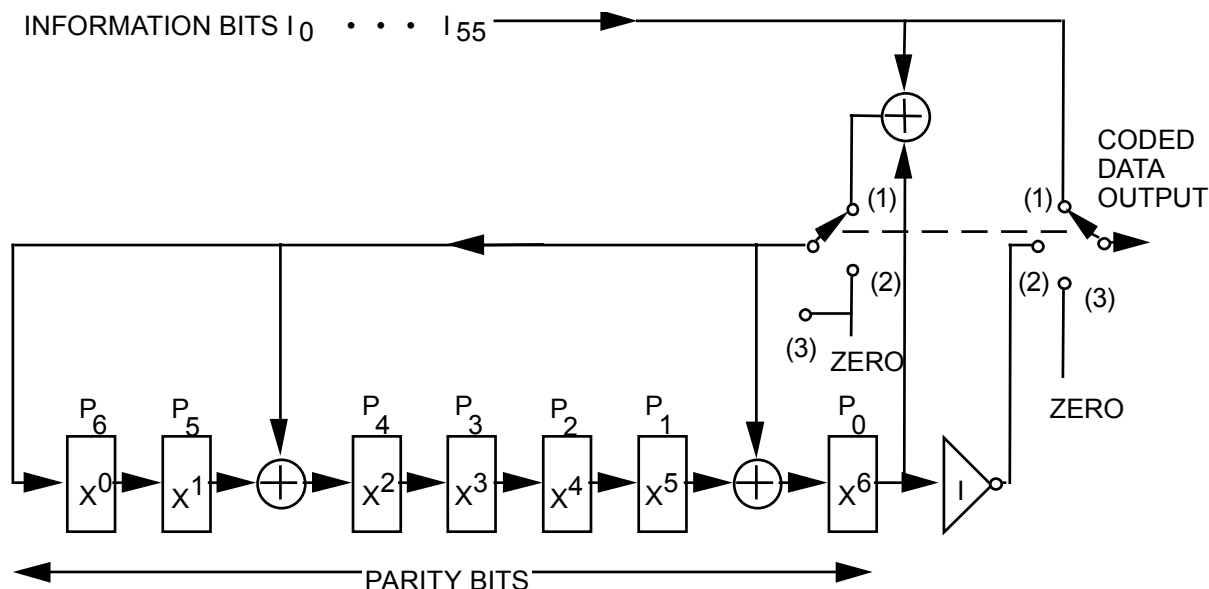

Figure 3-2: (63,56) Modified BCH Code Generator

3.4 FILL DATA

3.4.1 If the Transfer Frame(s) to be transmitted in a CLTU do not fit exactly within an integral number of BCH codewords, then ‘fill’ bits shall be appended to the last Transfer Frame to be transmitted in the CLTU until an integral number of BCH codewords is completed.

3.4.2 The pattern of the fill shall consist of a sequence of alternating ‘ones’ and ‘zeros’, starting with a ‘zero’.

NOTE – The Synchronization and Channel Coding Sublayer could require the introduction of these fill data in the encoding process; they are not removed by the decoding process. Removal of fill is the responsibility of the sublayer above, which delimits the end of the Transfer Frame(s) and discards extraneous bits (e.g., fill).

3.4.3 If randomization is used, the fill data mentioned above shall be added either before or after randomization.

NOTE – If randomization is being used, any fill octets that were added to the last codeword of the CLTU will be derandomized even if they were not randomized.

3.5 DECODING PROCEDURE

Codewords that have been encoded using the modified BCH code described in 3.3 may be decoded either in an error-detecting mode (Triple Error Detection, or TED) or in an error-correcting mode (Single Error Correction, or SEC), depending on mission requirements. When the error-detecting mode is chosen, one, two or three bits in error will be detected within the codeword (not counting the appended Filler Bit); when the error-correcting mode is chosen, one bit in error will be corrected and two bits in error will be detected.

NOTE – The decoding procedure described in 3.5 assumes the use of a hard-limiting detector before decoding, but the use of a soft-limiting detector is not intended to be precluded.

4 LDPC CODING

4.1 OVERVIEW

LDPC codes can be used to obtain greater coding gain than that provided by the BCH code. The two LDPC codes defined here are systematic. Both are transparent, so phase ambiguities may be resolved either from the Start Sequence, or by other means after decoding.

These LDPC codes possess relatively large minimum distance for their block length, and undetected error rates lie several orders of magnitude below detected frame and bit error rates for any given operating signal-to-noise ratio. This property, especially if combined with the optional Frame Error Control Field (FECF) defined in reference [1], assures an extremely low undetected error rate.

LDPC coding, by itself, cannot guarantee sufficient bit transitions to keep receiver symbol synchronizers in lock. Therefore, the Pseudo-Randomizer defined in section 5 is required.

4.2 SPECIFICATION

4.2.1 GENERAL

These LDPC codes are specified indirectly by an m -by- n parity-check matrix H consisting of m linearly independent rows. A coded sequence of n bits shall satisfy all m parity-check equations corresponding to the m rows of H .

An encoder shall map an input frame of $k=n-m$ information bits uniquely into a codeword of n bits.

NOTE – Two LDPC codes are specified, with codeword lengths ($n=128$, $k=64$) and ($n=512$, $k=256$), so that both have code rate $r=k/n=1/2$.

4.2.2 PARITY CHECK MATRICES

The H matrices shall be constructed from $M \times M$ submatrices, where $M=k/4=n/8$:

a) the H matrix for code 1 shall be:

$$H_{64 \times 128} = \begin{bmatrix} I_M \oplus \Phi^7 & \Phi^2 & \Phi^{14} & \Phi^6 & 0_M & \Phi^0 & \Phi^{13} & I_M \\ \Phi^6 & I_M \oplus \Phi^{15} & \Phi^0 & \Phi^1 & I_M & 0_M & \Phi^0 & \Phi^7 \\ \Phi^4 & \Phi^1 & I_M \oplus \Phi^{15} & \Phi^{14} & \Phi^{11} & I_M & 0_M & \Phi^3 \\ \Phi^0 & \Phi^1 & \Phi^9 & I_M \oplus \Phi^{13} & \Phi^{14} & \Phi^1 & I_M & 0_M \end{bmatrix}$$

b) the H matrix for code 2 shall be:

$$H_{256 \times 512} = \begin{bmatrix} I_M \oplus \Phi^{63} & \Phi^{30} & \Phi^{50} & \Phi^{25} & 0_M & \Phi^{43} & \Phi^{62} & I_M \\ \Phi^{56} & I_M \oplus \Phi^{61} & \Phi^{50} & \Phi^{23} & I_M & 0_M & \Phi^{37} & \Phi^{26} \\ \Phi^{16} & \Phi^0 & I_M \oplus \Phi^{55} & \Phi^{27} & \Phi^{56} & I_M & 0_M & \Phi^{43} \\ \Phi^{35} & \Phi^{56} & \Phi^{62} & I_M \oplus \Phi^{11} & \Phi^{58} & \Phi^3 & I_M & 0_M \end{bmatrix}$$

where I_M and 0_M are the $M \times M$ identity and zero matrices, respectively, and Φ is the first right circular shift of I_M . That is, Φ has a non-zero entry in row i and column j if $j=i+1 \pmod M$. It should be noted that Φ^2 is the second right circular shift of I_M , etc., and $\Phi^0=I_M$. The \oplus operator indicates modulo-2 addition.

4.3 ENCODING PROCEDURE

4.3.1 LDPC codewords consistent with the parity-check matrices shall be generated using one of the two methods described in 4.3.2 and 4.3.3.

4.3.2 One method for producing codewords consistent with the parity-check matrices is to perform matrix multiplication by block-circulant generator matrices. These matrices shall be constructed as follows:

- 1) P shall be the $4M \times 4M$ submatrix of H consisting of the last $4M$ columns, and Q shall be the $4M \times 4M$ submatrix of H consisting of the first $4M$ columns;
- 2) $W = (P^{-1}Q)^T$ shall be computed, where the arithmetic is performed modulo-2;
- 3) the matrix $G = [I_{4M} \quad W]$ shall be constructed, where I_{4M} is the $4M \times 4M$ identity matrix, and W is a dense matrix of circulants of size $4M \times 4M$.

4.3.3 Another method for producing codewords consistent with the parity-check matrices is to construct the matrices W from the hexadecimal values in tables 4-1 and 4-2:

- a) rows 1, $M+1$, $2M+1$, and $3M+1$ shall be found by converting the hexadecimal values to binary strings;
- b) the other rows shall be constructed from right circular shifts of those strings.

Table 4-1: Generator Matrix for ($n=128,k=64$) LDPC Code

$W_{64 \times 64}$	
Row 1	0E69 166B EF4C 0BC2
Row 17	7766 137E BB24 8418
Row 33	C480 FEB9 CD53 A713
Row 49	4EAA 22FA 465E EA11

Table 4-2: Generator Matrix for ($n=512,k=256$) LDPC Code

$W_{256 \times 256}$	
Row 1	1D21794A22761FAE 59945014257E130D 74D6054003794014 2DADEB9CA25EF12E
Row 65	60E0B6623C5CE512 4D2C81ECC7F469AB 20678DBFB7523ECE 2B54B906A9DBE98C
Row 129	F6739BCF54273E77 167BDA120C6C4774 4C071EFF5E32A759 3138670C095C39B5
Row 193	28706BD045300258 2DAB85F05B9201D0 8DFDEE2D9D84CA88 B371FAE63A4EB07E

4.4 FILL DATA

4.4.1 If the Transfer Frame(s) to be transmitted in a CLTU do not fit exactly within an integral number of LDPC codewords, then ‘fill’ bits shall be appended to the (last) Transfer Frame to be transmitted in the CLTU until an integral number of LDPC codewords is completed.

4.4.2 The pattern of the fill shall consist of a sequence of alternating ‘ones’ and ‘zeros’, starting with a ‘zero’.

4.4.3 The fill data shall be added before encoding. It shall be encoded and randomized with the Transfer Frame.

NOTE – The Synchronization and Channel Coding Sublayer may require the introduction of these fill data in the encoding process; they are not removed by the decoding process. Removal of fill is the responsibility of the sublayer above, which delimits the end of the Transfer Frame(s) and discards extraneous bits (e.g., fill).

4.5 DECODING PROCEDURE

An LDPC code should be decoded using ‘soft symbols’, rather than the binary ‘hard symbols’ typically used for a BCH code.

NOTE – This provides a performance improvement of about 2 dB, but depends on a receiver that can produce soft outputs. This modification is not mandatory, however, since a belief propagation decoder can also operate on binary symbols.

5 COMMUNICATIONS LINK TRANSMISSION UNIT

5.1 INTRODUCTION

5.1.1 Synchronization for the codeword and delimiting of the beginning of user data are provided by the Communications Link Transmission Unit (CLTU) data structure.

5.1.2 Resolution of data ambiguity (sense of ‘1’ and ‘0’) when receiving the symbol stream shall be a service of the Synchronization and Channel Coding Sublayer if it is not performed by the Physical Layer (e.g., with a differential modulation technique). In the Synchronization and Channel Coding Sublayer, ambiguity resolution shall use inherent information in the CLTU Start Sequence.

5.2 CLTU UNIT FORMAT

5.2.1 STRUCTURE OF A CLTU

The CLTU is the data structure which carries the data as a contiguous series of encoded codewords across the Synchronization and Channel Coding Sublayer. The data contained in the codewords in the CLTU consist of Transfer Frame(s) from the sublayer above (possibly with fill data). The CLTU has the structural components shown in figure 5-1 when BCH coding is used, and in figure 5-2 when LDPC coding is used.

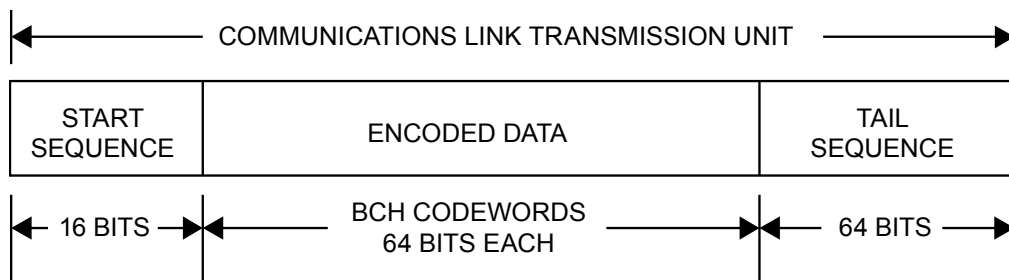

Figure 5-1: Components of the CLTU when BCH Coding Is Used

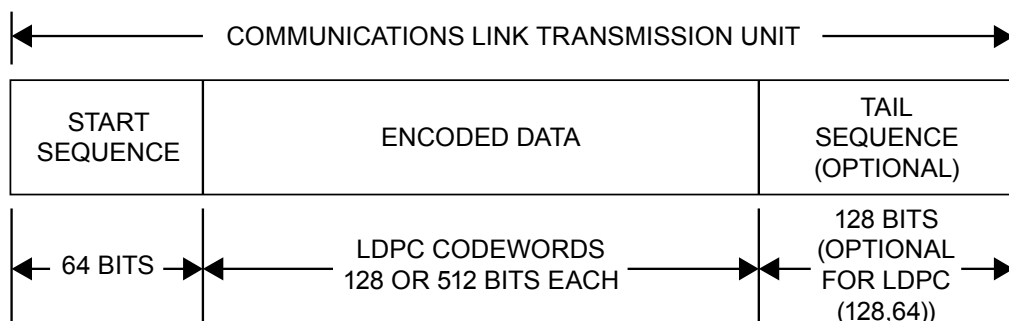
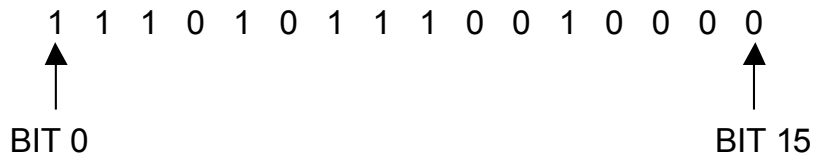

Figure 5-2: Components of the CLTU when LDPC Coding Is Used

5.2.2 START SEQUENCE

5.2.2.1 The CLTU Start Sequence field shall delimit the start of the encoded data within the CLTU.

5.2.2.2 When using BCH coding, the Start Sequence shall consist of the following 16-bit synchronization pattern:



5.2.2.3 When using LDPC coding, the Start Sequence shall consist of the following 64-bit synchronization pattern:

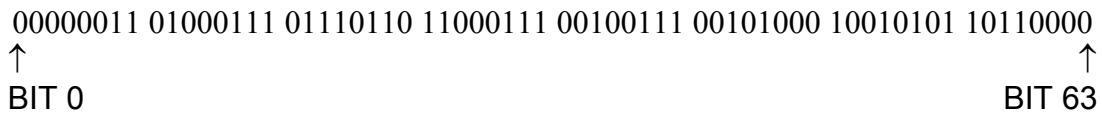

NOTE – In hexadecimal, this pattern is 0347 76C7 2728 95B0.

5.2.3 ENCODED DATA

The Encoded Data field shall consist of a set of codewords which have been encoded in accordance with either the BCH codeword encoding procedure in section 3 or the LDPC codeword encoding procedure in section 4.

NOTES

- 1 In addition to error control bits, these codewords contain the Transfer frame(s), plus any fill data that were appended to meet codeword length constraints.
- 2 The Transfer Frames contained in the Encoded Data field are randomized if LDPC coding is used; randomization is optional with BCH coding.

5.2.4 TAIL SEQUENCE

5.2.4.1 Tail Sequence for BCH Coding

The CLTU Tail Sequence field applicable for BCH coding is a 64-bit pattern that shall be used to delimit the end of a CLTU. The sequence is constructed specifically to be a non-correctable pattern which stops the decoding process.

The Tail Sequence shall consist of the following 64-bit pattern:

```

11000101 11000101 11000101 11000101 11000101 11000101 11000101 11000101 01111001
  ↑                                     ↑
  BIT 0                               BIT 63
    
```

NOTE – In hexadecimal, this pattern is C5C5 C5C5 C5C5 C579.

5.2.4.2 Tail Sequence for LDPC (128, 64) Coding

The CLTU Tail Sequence field optionally applicable for LDPC (128, 64) coding shall be a 128-bit pattern that may be used to delimit the end of a CLTU. The sequence is constructed specifically to be a non-correctable pattern which stops the decoding process.

The Tail Sequence shall consist of the following 128-bit pattern:

```

01010101 01010101 01010101 01010110 10101010 10101010 10101010 10101010
                01010101 01010101 01010101 01010101 01010101 01010101 01010101 01010101
  ↑                                     ↑
  BIT 0                               BIT 127
    
```

NOTES

- 1 In hexadecimal, this pattern is 5555 5556 AAAA AAAA 5555 5555 5555 5555
- 2 A conventional LDPC decoder will reliably fail to decode when it over-runs the end of a CLTU, and this property may be used to stop the decoding process without the need for a Tail Sequence. Different decoding algorithms may not have this property, and the corresponding decoders may be used if the Tail Sequence is transmitted at the end of each CLTU. Subsection 8.2 specifies for managed parameters relevant to the Tail Sequence.

5.2.4.3 CLTU Termination for LDPC (512, 256)

No Tail Sequence shall be used for the LDPC (512, 256).

NOTE – A conventional LDPC decoder will reliably fail to decode when it over-runs the end of a CLTU, and this property is used to stop the decoding process.

5.3 CLTU RECEPTION LOGIC

The CLTU Reception Logic at the receiving end is presented in state diagram form (figure 5-3). To support the state diagrams, a list of ‘states’ and ‘events’ is given in tables 5-1 and 5-2.

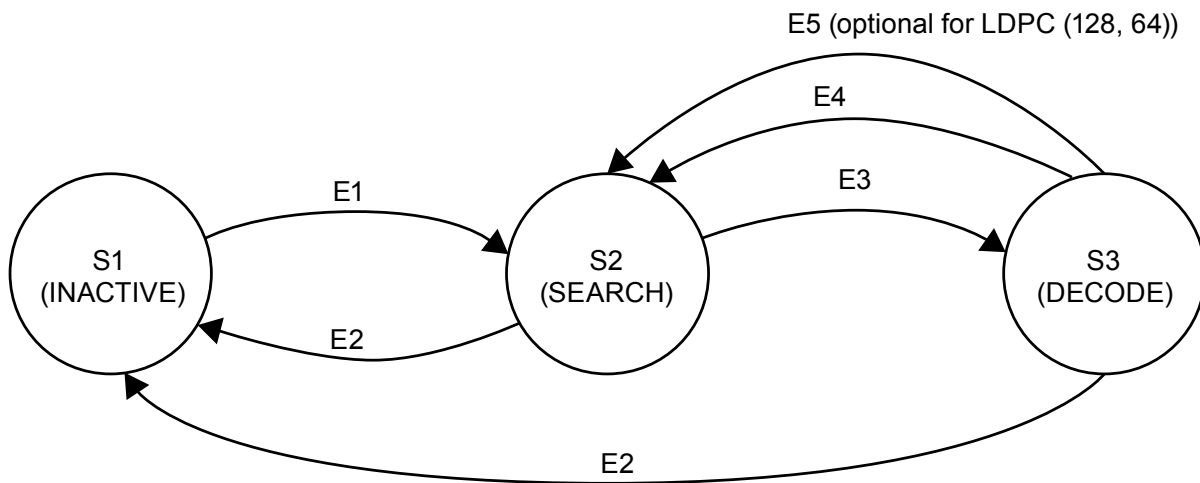

Figure 5-3: CLTU Reception State Diagram (Receiving End)

Table 5-1: CLTU Reception States (Receiving End)

State Number	State Name	State Definition
S1	INACTIVE	The communications channel is INACTIVE (i.e., 'no bit lock is achieved', or, alternatively, 'no bit modulation is detected').
S2	SEARCH	The incoming bit stream is searched, bit by bit, for the Start Sequence pattern.
S3	DECODE	1) Codewords, which are either free of error or which can be corrected, are received, decoded, and derandomized (if necessary), and their contents are transferred to the sublayer above. 2) Optional: Following each codeword, the incoming bit stream is compared to the Tail Sequence pattern.

Table 5-2: CLTU Reception Events (Receiving End)

Event Number	Event Name	Event Definition
E1	CHANNEL ACTIVATION	Carrier modulation is detected and bit lock is achieved: channel symbol stream is present.
E2	CHANNEL DEACTIVATION	Bit lock is lost or communications signal is lost: channel symbol stream is NOT present.
E3	START SEQUENCE FOUND	The Start Sequence pattern has been detected, signaling the beginning of the first codeword of the CLTU.
E4	CODEWORD REJECTION	The decoder has indicated uncorrected errors. No data from this decoding attempt are transferred to the sublayer above. When no Tail Sequence is used, the search for the Start Sequence must resume at the beginning of the uncorrected codeword. When a Tail Sequence is used, the search may resume at the end of the uncorrected codeword.
E5	TAIL SEQUENCE FOUND	Optional for (128, 64) LDPC: The Tail Sequence has been detected, signaling the end of a CLTU. The search for the Start Sequence resumes at the end of the Tail Sequence.

NOTES

- 1 In the search for the Start Sequence in State 2, no error in the Start Sequence is allowed if the modified BCH code is decoded in the error-detecting mode; one error in the Start Sequence is allowed if the modified BCH code is decoded in the error-correcting mode.
- 2 When LDPC codes are used, a Tail Sequence is optional for the (128, 64) code at the end of each CLTU. If a Tail Sequence is transmitted, one may wish to check for its presence, e.g., with a correlator, rather than relying on the decoder to fail at the end of the CLTU. If so, one must allow for data ambiguity (sense of '1' and '0'). When BCH codes are used, it is standard practice to rely on codeword rejection when the decoder encounters the Tail Sequence.

6 RANDOMIZER

6.1 OVERVIEW

In order to maintain bit (or symbol) synchronization with the received communications signal, every data capture system at the receiving end requires that the incoming signal have a minimum bit transition density (see subsection 2.2.3 in reference [4]).

In order to ensure proper receiver operation, the data stream needs to be sufficiently random. The Pseudo-Randomizer defined in this section is the preferred method to ensure sufficient randomness for all combinations of CCSDS-recommended modulation and coding schemes.

When BCH coding is used, the Pseudo-Randomizer defined in this section is required unless the system designer verifies proper operation of the system if this Randomizer is not used. Its use is fixed for a Physical Channel and is managed (i.e., its presence or absence is not signaled but is known a priori by the receiver), per table 8-2.

Randomization is always applied when LDPC coding is used.

When BCH coding is used, the random sequence is applied to the **Transfer Frame(s)** prior to encoding at the sending end and removed from the Transfer Frame(s) after decoding at the receiving end.

When LDPC coding is used, the random sequence is applied to the codeword(s) after encoding at the sending end and removed from the noisy codeword(s) prior to decoding at the receiving end.

6.2 RANDOMIZER DESCRIPTION

The random sequence shall be generated using the following polynomial:

$$h(x) = x^8 + x^6 + x^4 + x^3 + x^2 + x + 1$$

This sequence repeats after 255 bits, continuing as needed. The first 40 bits of the sequence are

1111 1111 0011 1001 1001 1110 0101 1010 0110 1000

Increasing Time----->

NOTE – Figure 6-1 depicts a basic logic diagram of the Bit Transition Generator (BTG).

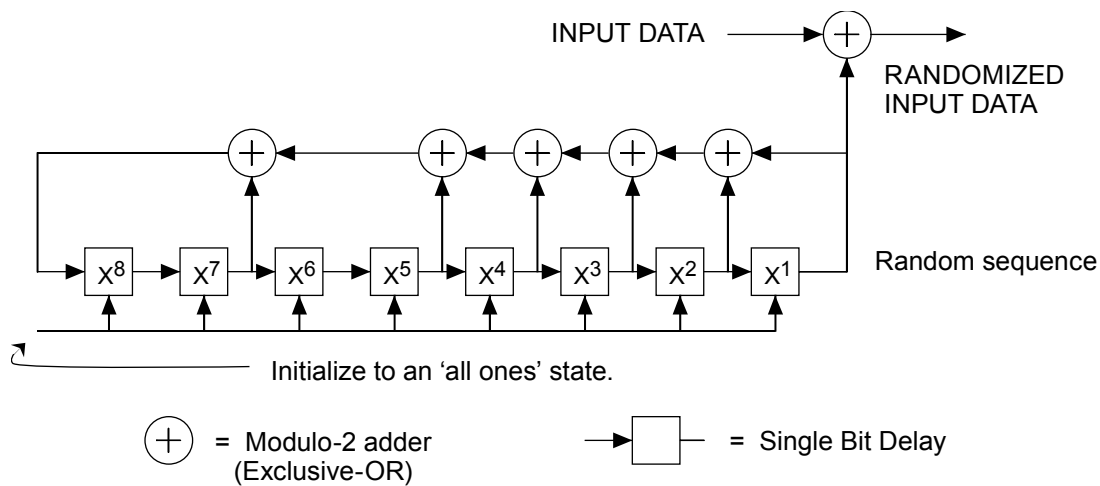

Figure 6-1: Bit Transition Generator Logic Diagram

6.3 APPLICATION OF THE RANDOMIZER

6.3.1 When BCH coding is used with the Pseudo-Randomizer, randomization shall be applied only to the Transfer Frame(s). The BTG shall be preset to the ‘all-ones’ state at the start of Transfer Frame(s) and then shall be exclusively ORed, bit by bit, with the Transfer Frame(s) until the process ends with the last bit of the Transfer Frame(s) to be transmitted in a CLTU.

NOTES

- 1 Requirements for randomization of fill data are specified in 3.4.3 for BCH coding.
- 2 Randomization for BCH coding is optional and managed per table 8-2.

6.3.2 When LDPC coding is used, randomization shall be applied only to the codewords. The BTG shall be preset to the ‘all-ones’ state at the start of each codeword and then shall be exclusively ORed, symbol by symbol, with the codeword.

NOTE – Requirements for randomization of fill data are specified in 4.4.3 for LDPC coding.

6.3.3 When BCH coding is used, at the receiving end, the derandomization shall be applied to the successfully decoded data.

6.3.3.1 The BTG shall remain in the ‘all-ones’ state until the CLTU Start Sequence has been detected.

6.3.3.2 The BTG pattern shall be exclusively ORed, bit by bit, to the successfully decoded data (after the Error Control Bits have been removed).

6.3.3.3 The BTG shall be reset to the ‘all-ones’ state following a failure of the decoder to successfully decode a codeword or other loss of data.

6.3.4 When LDPC coding is used, at the receiving end, the derandomization shall be applied to the noisy codewords prior to decoding.

6.3.4.1 The BTG shall remain in the ‘all-ones’ state until the start of a codeword has been detected.

6.3.4.2 The BTG pattern shall be used to derandomize the received codeword, symbol by symbol.

NOTE – Implementation details depend on the LDPC decoder used; for example, a hard-decision decoder may use an exclusive OR operation, while a soft-decision decoder may invert the signs of the soft symbols according to the BTG pattern.

6.3.4.3 The BTG shall be reset to the ‘all-ones’ state following each codeword.

7 PHYSICAL LAYER OPERATIONS PROCEDURES

7.1 INTRODUCTION

7.1.1 Operations within the Physical Layer begin with the activation of the physical communications channel by invoking the radio frequency carrier and modulation techniques. These techniques include provision of any required subcarrier(s) and data modulation in order to establish the physical connection from the transmitter to the receiver. During a communications session, a series of CLTUs is transmitted to the receiver. The session ends with the removal of the carrier.

7.1.2 The Physical Layer Operations Procedures (PLOPs) specify the sequence of operations performed during a communications session. Two procedures, PLOP-1 and PLOP-2, are currently defined. The selection of PLOPs is mission-specific.

7.1.3 PLOP-2 shall be used for missions whose planning begins after September 2010.

7.1.4 PLOP-1 may still be used in ground equipment for the support of legacy missions.

7.2 DATA FORMATS

7.2.1 GENERAL

The data formats used by the PLOPs are:

- a) the Acquisition Sequence;
- b) CLTU; and
- c) the Idle Sequence.

They are used to provide synchronization of the symbol stream, and are described in 7.2.2 through 7.2.4.

7.2.2 ACQUISITION SEQUENCE

The Acquisition Sequence is a data structure forming a preamble which provides for initial symbol synchronization within the incoming stream of detected symbols. The length of the Acquisition Sequence shall be selected according to the communications link performance requirements of the mission, but the preferred minimum length is 16 octets. The length is not required to be an integral multiple of octets. The pattern of the Acquisition Sequence shall be alternating 'ones' and 'zeros', starting with either a 'one' or a 'zero'.

7.2.3 CLTU

The CLTU is the data structure (symbol sequence) furnished from the Synchronization and Channel Coding Sublayer, and defined in 5.2. It contains the data symbols that are to be transmitted to the receiving end.

When BCH coding is used, each codeword within the CLTU, having the format specified in 3.2, shall provide at least 2 data transitions per codeword. If the receiver symbol synchronization design necessitates more frequent transitions, either the CLTU as delivered to the Physical Layer must have been randomized as described in section 6, or the Physical Layer must invoke a technique (modulation type, phase-coherent data and subcarrier, or other) to guarantee sufficiently frequent transitions for adequate symbol synchronization.

When LDPC coding is used, the randomizer described in section 6 is required. With high probability, this assures a large number of data transitions.

7.2.4 IDLE SEQUENCE

The Idle Sequence is the data structure which provides for maintenance of symbol synchronization in the absence of CLTUs. The bit pattern is a sequence of alternating 'ones' and 'zeros'. The length of the Idle Sequence is an unconstrained number of bits.

NOTE – In the first issue of reference [D2], the Idle Sequence was constrained to begin with a 'zero' to be continuous with the CLTU Tail Sequence. Because of the improved performance of the Tail Sequence introduced later and specified in this Recommended Standard, the constraint is no longer necessary.

7.3 CARRIER MODULATION MODES

7.3.1 A PLOP consists of a sequential application of the various Carrier Modulation Modes (CMMs) in order to activate and deactivate the physical communications channel.

7.3.2 CMMs consist of different states of data modulation upon the RF carrier which creates the physical communications channel. The physical methods of modulating the carrier are described in reference [4]. The Carrier Modulation Modes are shown in table 7-1.

Table 7-1: Carrier Modulation Modes

Mode	State
CMM-1	Unmodulated CARRIER only
CMM-2	CARRIER modulated with ACQUISITION SEQUENCE
CMM-3	CARRIER modulated with CLTU
CMM-4	CARRIER modulated with IDLE SEQUENCE

7.4 PLOP-1

7.4.1 PLOP-1 is a procedure for individually radiating CLTUs, whereby the receiver is always forced into the INACTIVE state (S1) (see 5.3) by deactivating the physical communications channel after the end of transmission of each CLTU (or CLTU followed by an Idle Sequence).

7.4.2 PLOP-1 invokes the sequence of CMMs shown in figure 7-1. Note that ‘unmodulated’ is defined as the state in which no *data* modulation is present.

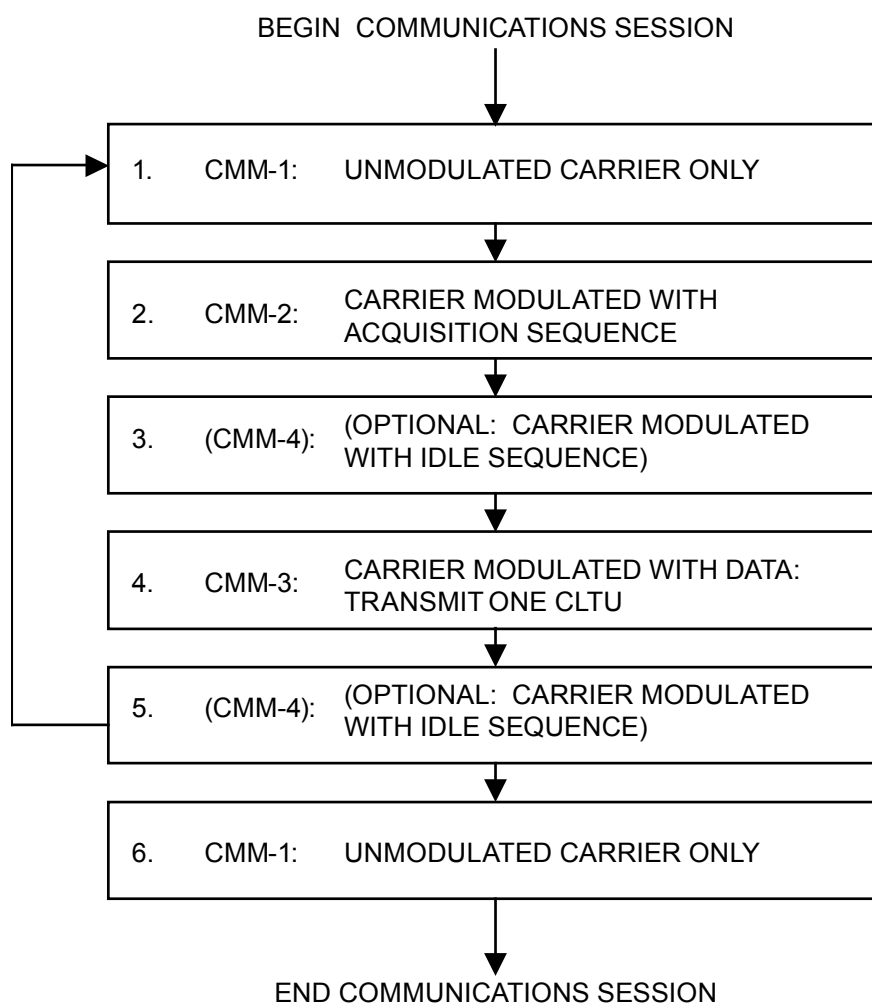

Figure 7-1: Sequence of CMMs Composing PLOP-1

7.5 PLOP-2

7.5.1 PLOP-2 is a procedure whereby the physical communications channel is not deactivated after each transmitted CLTU. The termination of an individual CLTU shall be provided only through the data path, using the CLTU Tail Sequence and, optionally, Idle Sequence. This places the receiver in the SEARCH state (S2) (see 5.3) after each CLTU. The receiver is forced into the INACTIVE state (S1) by deactivating the physical communications channel only at the end of transmission of a series of CLTUs, which may or may not be followed by an Idle Sequence.

7.5.2 It should be noted that when operating with PLOP-2, it is recommended that a minimum Idle Sequence of one octet be systematically inserted between each CLTU to eliminate the small but finite possibility of synchronization lockout. Such a lockout may occur if the start pattern of one CLTU is not detected (leaving the receiver in SEARCH state) and a Start Sequence exists over the last bits of the last codeword of that CLTU and the first bits of its Tail Sequence. This creates an erroneous but temporary CLTU start (DECODE

state), causing the true start of the following CLTU to be missed. The added Idle Sequence prevents this from happening. The CLTU transmission service specified in reference [5] includes a parameter to set the duration of the Idle Sequence following a CLTU.

7.5.3 PLOP-2 invokes the sequence of CMMs shown in figure 7-2. Note that ‘unmodulated’ is defined as the state in which no *data* modulation is present.

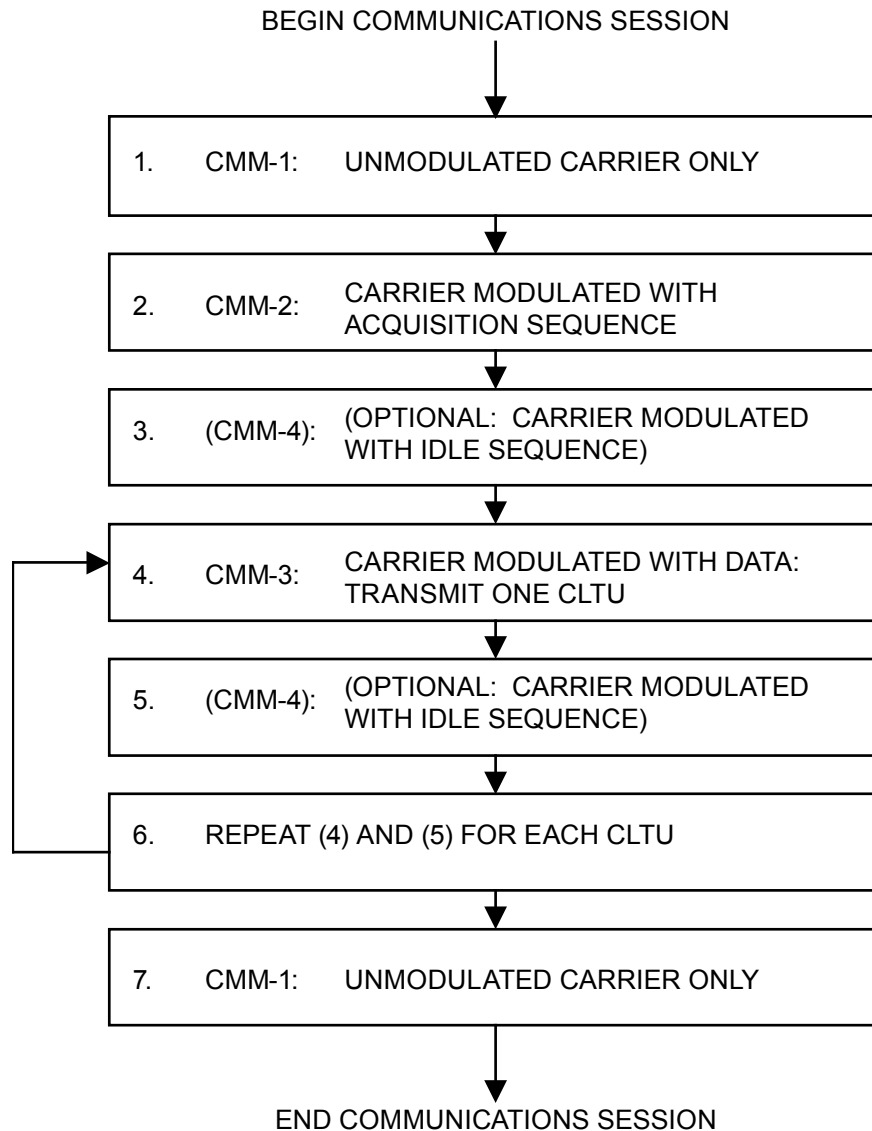

Figure 7-2: Sequence of CMMs Composing PLOP-2

8 MANAGED PARAMETERS

8.1 OVERVIEW OF MANAGED PARAMETERS

In order to conserve bandwidth on the space link, some parameters associated with synchronization and channel coding are handled by management rather than by inline communications protocol. The managed parameters are those which tend to be static for long periods of time, and whose change generally signifies a major reconfiguration of the synchronization and channel coding systems associated with a particular mission. Through the use of a management system, management conveys the required information to the synchronization and channel coding systems.

In this section, the managed parameters used by synchronization and channel coding systems are listed. These parameters are defined in an abstract sense and are not intended to imply any particular implementation of a management system.

8.2 MANAGED PARAMETERS FOR BCH AND LDPC CODING

Table 8-1 lists the managed parameters common to both BCH and LDPC coding. Table 8-2 lists additional managed parameters specific to BCH coding. Table 8-3 lists additional managed parameters specific to LDPC coding.

Table 8-1: Managed Parameters for Both BCH and LDPC Codes

Managed Parameter	Allowed Values
Error Correcting Code Type	BCH, LDPC
Maximum CLTU Length (octets)	Integer
Maximum value for the Repetitions parameter NOTE – If the maximum value is 1, then the repeated transmissions option is not available.	Integer
Physical Layer Operations Procedure	PLOP-1, PLOP-2

Table 8-2: Additional Managed Parameters when the BCH Code Is Used

Managed Parameter	Allowed Values
Decoding Mode	Error-Detecting, Error-Correcting
Allowed Number of Errors in Start Sequence	0,1
Randomizer	Used, Not used

Table 8-3: Additional Managed Parameters when an LDPC Codes Is Used

Managed Parameter	Allowed Values
Code length	$(n=128, k=64)$, $(n=512, k=256)$
Tail Sequence (only for LDPC (128, 64))	Used, Not used

NOTE – When an LDPC code is used, one typically would not use a ‘hard correlator’ that counts the number of errors in a tentative Start Sequence. Instead, an algorithm based on ‘soft symbols’ would be more reliable at low SNR, and so it is not meaningful to specify an allowed number of errors in the Start Sequence. Likewise, an LDPC decoder typically works from soft symbols as well, and does not have explicit error detecting and error correcting modes.

ANNEX A

SERVICE DEFINITION

(NORMATIVE)

A1 GENERAL

This annex provides service definition in the form of primitives, which present an abstract model of the logical exchange of data and control information between the service provider and the service user. The definitions of primitives are independent of specific implementation approaches.

The parameters of the primitives are specified in an abstract sense and specify the information to be made available to the user of the primitives. The way in which a specific implementation makes this information available is not constrained by this specification. In addition to the parameters specified in this annex, an implementation may provide other parameters to the service user (e.g., parameters for controlling the service, monitoring performance, facilitating diagnosis, and so on).

A2 OVERVIEW OF THE SERVICE

The TC Synchronization and Channel Coding provides unidirectional (one way) transfer of a sequence of TC or USLP Transfer Frames over a Physical Channel across a space link, with optional error detection/correction.

Only one user can use this service on a Physical Channel, and Transfer Frames from different users are not multiplexed together within one Physical Channel.

A3 SERVICE PARAMETERS

The parameter Frames is the service data unit of this service and, at the sending end, shall consist of one or more TC Transfer Frames defined in reference [1] or a single USLP Transfer Frame defined in reference [6]. At the receiving end, however, the parameter Frames may contain an incomplete Frame or additional fill data, which are discarded by the applicable Space Data Link Protocol.

If the optional Repetitions parameter is supported, then the parameter shall contain a positive integer value, greater than or equal to 1. If the value of the Repetitions parameter is greater than 1, then the Frames parameter should not contain any Type-BD frames defined in reference [1].

A4 SERVICE PRIMITIVES

A4.1 GENERAL

The service primitives associated with this service are:

- a) ChannelAccess.request;
- b) ChannelAccess.indication.

The ChannelAccess.request primitive is passed from the service user at the sending end to the service provider to request that either a single USLP Transfer Frame (reference [6]) or one or more TC Transfer Frames (reference [1]) be transferred to the user at the receiving end through the Physical Channel.

The ChannelAccess.indication is passed from the service provider to the service user at the receiving end to deliver Frames.

A4.2 CHANNELACCESS.REQUEST

A4.2.1 Function

The ChannelAccess.request primitive is the service request primitive for this service.

A4.2.2 Semantics

The ChannelAccess.request primitive shall provide one or two parameters as follows:

ChannelAccess.request (Frame(s), Repetitions)

NOTES

- 1 Support for the Repetitions parameter is optional.
- 2 The use of the Repetitions parameter with values greater than 1 should be restricted to links with long light time delays.
- 3 For a link with long light time delay, the use of the Repetitions parameter with a value greater than 1 can improve the probability that a sequence of frames is successfully received during a limited transmission session. Further improvement of the probability can be obtained by restricting the Frames parameter to consist of a single Transfer Frame: in fact, in a CLTU with multiple frames, the loss of a frame causes the loss of all subsequent frames in the same CLTU and, in addition, the probability of loss increases with the length of the CLTU.

A4.2.3 When Generated

The ChannelAccess.request primitive is passed to the service provider at the sending end to request it to process and send the Frames.

A4.2.4 Effect On Receipt

Receipt of the ChannelAccess.request primitive shall cause the service provider to perform the functions described in section 2.3.1 and to transfer the resulting CLTU. If the Repetitions parameter is supported, then the service provider shall transfer the CLTU the number of times specified by the Repetitions parameter.

NOTE – The value in the Repetitions parameter specifies the number of times the CLTU is transferred, not the additional transfers after the first one. For example, if the value of Repetitions is 3, then the service provider transfers the CLTU three times.

A4.3 CHANNELACCESS.INDICATION

A4.3.1 Function

The ChannelAccess.indication primitive is the service indication primitive for this service.

A4.3.2 Semantics

The ChannelAccess.indication primitive shall provide a parameter as follows:

ChannelAccess.indication (Frames)

A4.3.3 When Generated

The ChannelAccess.indication primitive is passed from the service provider to the service user at the receiving end to deliver Frames.

A4.3.4 Effect On Receipt

The effect of receipt of the ChannelAccess.indication primitive by the service user is undefined.

ANNEX B

SECURITY, SANA, AND PATENT CONSIDERATIONS

(INFORMATIVE)

B1 SECURITY CONSIDERATIONS

B1.1 SECURITY BACKGROUND

It is assumed that security is provided by encryption, authentication methods, and access control to be performed at higher layers (Application and/or Transport Layers). Mission and service providers are expected to select from recommended security methods, suitable to the specific application profile. Specification of these security methods and other security provisions is outside the scope of this Recommended Standard. The coding sublayer has the objective of delivering data with the minimum possible amount of residual errors. The LDPC codes are very good at detecting any uncorrectable errors, as is the BCH code when used in its error-detect mode, or when used in conjunction with the Frame Error Control Field (FECF). However, there remains an extremely low probability that additional undetected errors may escape this scrutiny. These errors may affect the encryption process in unpredictable ways, possibly affecting the decryption stage and producing data loss, but will not compromise the security of the data.

B1.2 SECURITY CONCERNS

Security concerns in the areas of data privacy, authentication, access control, availability of resources, and auditing are to be addressed in higher layers and are not related to this Recommended Standard. The coding sublayer does not affect the proper functioning of methods used to achieve such protection at higher layers, except for undetected errors, as explained above.

The physical integrity of data bits is protected from channel errors by the coding systems specified in this Recommended Standard. In case of congestion or disruption of the link, the coding sublayer provides methods for frame resynchronization.

B1.3 POTENTIAL THREATS AND ATTACK SCENARIOS

An eavesdropper can receive and decode the codewords, but will not be able to get to the user data if proper encryption is performed at a higher layer. An interferer could affect the performance of the decoder by congesting it with unwanted data, but such data would be rejected by the authentication process. Such interference or jamming must be dealt with at the Physical Layer and through proper spectrum regulatory entities.

B1.4 CONSEQUENCES OF NOT APPLYING SECURITY

There are no specific security measures prescribed for the coding sublayer. Therefore consequences of not applying security are only imputable to the lack of proper security measures in other layers. Residual undetected errors may produce additional data loss when the link carries encrypted data.

B2 SANA CONSIDERATIONS

The recommendations of this document do not require any action from SANA.

B3 PATENT CONSIDERATIONS

CCSDS member agencies have not filed any patents specific to the proposed (128,64) and (512,256) LDPC codes described in section 5, and CCSDS is not aware of any patents that apply to these codes in particular. There are dozens, probably hundreds, of patents filed on the general topics of LDPC codes and LDPC decoders. In this environment, it is impossible to know what is covered and what is not. However, many companies have successfully implemented commercial products including LDPC encoders and decoders.

ANNEX C

ABBREVIATIONS AND ACRONYMS

(INFORMATIVE)

This annex lists key acronyms and terms that are used throughout this Recommended Standard to describe synchronization and channel coding.

BCH	Bose-Chaudhuri-Hocquenghem
BTG	Bit Transition Generator
CCSDS	Consultative Committee For Space Data Systems
CLTU	Communications Link Transmission Unit
CMM	Carrier Modulation Mode
FECF	Frame Error Control Field
LDPC	Low Density Parity Check
MSB	Most Significant Bit
NRZ-M	Non-Return-to-Zero-Mark
PLOP	Physical Layer Operations Procedure
TC	Telecommand
USLP	Unified Space Data Link Protocol

ANNEX D

INFORMATIVE REFERENCES

(INFORMATIVE)

- [D1] *Organization and Processes for the Consultative Committee for Space Data Systems*. Issue 4. CCSDS Record (Yellow Book), CCSDS A02.1-Y-4. Washington, D.C.: CCSDS, April 2014.
- [D2] *Telecommand Part 1—Channel Service*. Issue 3-S. Recommendation for Space Data System Standards (Historical), CCSDS 201.0-B-3-S. Washington, D.C.: CCSDS, (June 2000) August 2005.

NOTE – Normative references are listed in 1.6.3.