

Recommendation for Space Data System Standards

SPACE LINK EXTENSION— FORWARD CLTU SERVICE SPECIFICATION

RECOMMENDED STANDARD

CCSDS 912.1-B-5

BLUE BOOK

July 2023

Recommendation for Space Data System Standards

SPACE LINK EXTENSION— FORWARD CLTU SERVICE SPECIFICATION

RECOMMENDED STANDARD

CCSDS 912.1-B-5

BLUE BOOK

July 2023

AUTHORITY

Issue:	Recommended Standard, Issue 5
Date:	July 2023
Location:	Washington, DC, USA

This document has been approved for publication by the Management Council of the Consultative Committee for Space Data Systems (CCSDS) and represents the consensus technical agreement of the participating CCSDS Member Agencies. The procedure for review and authorization of CCSDS documents is detailed in *Organization and Processes for the Consultative Committee for Space Data Systems* (CCSDS A02.1-Y-4), and the record of Agency participation in the authorization of this document can be obtained from the CCSDS Secretariat at the email address below.

This document is published and maintained by:

CCSDS Secretariat
National Aeronautics and Space Administration
Washington, DC, USA
Email: secretariat@mailman.ccsds.org

FOREWORD

Attention is drawn to the possibility that some of the elements of this document may be the subject of patent rights. CCSDS has processes for identifying patent issues and for securing from the patent holder agreement that all licensing policies are reasonable and non-discriminatory. However, CCSDS does not have a patent law staff, and CCSDS shall not be held responsible for identifying any or all such patent rights.

Through the process of normal evolution, it is expected that expansion, deletion, or modification of this document may occur. This Recommended Standard is therefore subject to CCSDS document management and change control procedures, which are defined in the *Organization and Processes for the Consultative Committee for Space Data Systems* (CCSDS A02.1-Y-4). Current versions of CCSDS documents are maintained at the CCSDS Web site:

<http://www.ccsds.org/>

Questions relating to the contents or status of this document should be sent to the CCSDS Secretariat at the email address indicated on page i.

At time of publication, the active Member and Observer Agencies of the CCSDS were:

Member Agencies

- Agenzia Spaziale Italiana (ASI)/Italy.
- Canadian Space Agency (CSA)/Canada.
- Centre National d'Etudes Spatiales (CNES)/France.
- China National Space Administration (CNSA)/People's Republic of China.
- Deutsches Zentrum für Luft- und Raumfahrt (DLR)/Germany.
- European Space Agency (ESA)/Europe.
- Federal Space Agency (FSA)/Russian Federation.
- Instituto Nacional de Pesquisas Espaciais (INPE)/Brazil.
- Japan Aerospace Exploration Agency (JAXA)/Japan.
- National Aeronautics and Space Administration (NASA)/USA.
- UK Space Agency/United Kingdom.

Observer Agencies

- Austrian Space Agency (ASA)/Austria.
- Belgian Science Policy Office (BELSPO)/Belgium.
- Central Research Institute of Machine Building (TsNIIMash)/Russian Federation.
- China Satellite Launch and Tracking Control General, Beijing Institute of Tracking and Telecommunications Technology (CLTC/BITTT)/China.
- Chinese Academy of Sciences (CAS)/China.
- China Academy of Space Technology (CAST)/China.
- Commonwealth Scientific and Industrial Research Organization (CSIRO)/Australia.
- Danish National Space Center (DNSC)/Denmark.
- Departamento de Ciência e Tecnologia Aeroespacial (DCTA)/Brazil.
- Electronics and Telecommunications Research Institute (ETRI)/Korea.
- European Organization for the Exploitation of Meteorological Satellites (EUMETSAT)/Europe.
- European Telecommunications Satellite Organization (EUTELSAT)/Europe.
- Geo-Informatics and Space Technology Development Agency (GISTDA)/Thailand.
- Hellenic National Space Committee (HNSC)/Greece.
- Hellenic Space Agency (HSA)/Greece.
- Indian Space Research Organization (ISRO)/India.
- Institute of Space Research (IKI)/Russian Federation.
- Korea Aerospace Research Institute (KARI)/Korea.
- Ministry of Communications (MOC)/Israel.
- Mohammed Bin Rashid Space Centre (MBRSC)/United Arab Emirates.
- National Institute of Information and Communications Technology (NICT)/Japan.
- National Oceanic and Atmospheric Administration (NOAA)/USA.
- National Space Agency of the Republic of Kazakhstan (NSARK)/Kazakhstan.
- National Space Organization (NSPO)/Chinese Taipei.
- Naval Center for Space Technology (NCST)/USA.
- Netherlands Space Office (NSO)/The Netherlands.
- Research Institute for Particle & Nuclear Physics (KFKI)/Hungary.
- Scientific and Technological Research Council of Turkey (TUBITAK)/Turkey.
- South African National Space Agency (SANSA)/Republic of South Africa.
- Space and Upper Atmosphere Research Commission (SUPARCO)/Pakistan.
- Swedish Space Corporation (SSC)/Sweden.
- Swiss Space Office (SSO)/Switzerland.
- United States Geological Survey (USGS)/USA.

DOCUMENT CONTROL

Document	Title	Date	Status
CCSDS 912.1-B-1	Space Link Extension—Forward CLTU Service Specification	April 2002	Original issue, superseded
CCSDS 912.1-B-2	Space Link Extension—Forward CLTU Service Specification	November 2004	Issue 2, superseded
CCSDS 912.1-B-3	Space Link Extension—Forward CLTU Service Specification, Recommended Standard, Issue 3	July 2010	Issue 3, superseded
CCSDS 912.1-B-4	Space Link Extension—Forward CLTU Service Specification, Recommended Standard	August 2016	Issue 4, superseded
CCSDS 912.1-B-5	Space Link Extension—Forward CLTU Service Specification, Recommended Standard, Issue 5	July 2023	Current issue: – adds support for USLP Transfer Frames; – adds clarifications and corrections.

NOTE – Substantive changes from the previous issue are indicated by change bars in the inside margin.

CONTENTS

<u>Section</u>	<u>Page</u>
1 INTRODUCTION	1-1
1.1 PURPOSE OF THIS RECOMMENDED STANDARD	1-1
1.2 SCOPE	1-1
1.3 APPLICABILITY	1-1
1.4 RATIONALE	1-2
1.5 DOCUMENT STRUCTURE	1-2
1.6 DEFINITIONS, NOMENCLATURE, AND CONVENTIONS	1-5
1.7 REFERENCES	1-12
2 DESCRIPTION OF THE FCLTU SERVICE	2-1
2.1 OVERVIEW	2-1
2.2 SPACE LINK EXTENSION REFERENCE MODEL	2-2
2.3 SERVICE MANAGEMENT	2-3
2.4 ARCHITECTURE MODEL – FUNCTIONAL VIEW	2-3
2.5 ARCHITECTURE MODEL – CROSS-SUPPORT VIEW	2-6
2.6 FUNCTIONAL DESCRIPTION	2-7
2.7 OPERATIONAL SCENARIO	2-14
2.8 SECURITY ASPECTS OF THE FCLTU SERVICE	2-15
3 FCLTU SERVICE OPERATIONS	3-1
3.1 GENERAL CONSIDERATIONS	3-1
3.2 CLTU-BIND	3-8
3.3 CLTU-UNBIND	3-15
3.4 CLTU-START	3-18
3.5 CLTU-STOP	3-22
3.6 CLTU-TRANSFER-DATA	3-25
3.7 CLTU-ASYNC-NOTIFY	3-33
3.8 CLTU-SCHEDULE-STATUS-REPORT	3-40
3.9 CLTU-STATUS-REPORT	3-44
3.10 CLTU-GET-PARAMETER	3-49
3.11 CLTU-THROW-EVENT	3-54
3.12 CLTU-PEER-ABORT	3-59
4 CLTU PROTOCOL	4-1
4.1 GENERIC PROTOCOL CHARACTERISTICS	4-1
4.2 FCLTU SERVICE PROVIDER BEHAVIOR	4-4

CONTENTS (continued)

<u>Section</u>	<u>Page</u>
ANNEX A DATA TYPE DEFINITIONS (NORMATIVE)	A-1
ANNEX B PRODUCTION STATUS (NORMATIVE)	B-1
ANNEX C CONFORMANCE OPTIONS MATRIX (NORMATIVE)	C-1
ANNEX D INDEX TO DEFINITIONS (INFORMATIVE)	D-1
ANNEX E ACRONYMS (INFORMATIVE)	E-1
ANNEX F THROW EVENT DEFINITIONS (INFORMATIVE)	F-1
ANNEX G INFORMATIVE REFERENCES (INFORMATIVE)	G-1

Figure

1-1 SLE Services Documentation	1-4
2-1 Forward TC Space Link Processing SLE-FG	2-4
2-2 FCLTU Service Production and Provision	2-5
2-3 Example of Management and Provision of FCLTU Service	2-6
2-4 Simplified FCLTU Service Provider State Transition Diagram	2-9
2-5 Communications Realization of FCLTU Service	2-12
B-1 FCLTU Production Status Transitions	B-1

Table

2-1 FCLTU Service Operations	2-8
3-1 Setting of FCLTU Service Configuration Parameters	3-6
3-2 CLTU-BIND Parameters	3-9
3-3 CLTU-UNBIND Parameters	3-16
3-4 CLTU-START Parameters	3-18
3-5 CLTU-STOP Parameters	3-22
3-6 CLTU-TRANSFER-DATA Parameters	3-25
3-7 CLTU-ASYNC-NOTIFY Parameters	3-33
3-8 CLTU-SCHEDULE-STATUS-REPORT Parameters	3-40
3-9 CLTU-STATUS-REPORT Parameters	3-44
3-10 CLTU-GET-PARAMETER Parameters	3-49
3-11 FCLTU Service Parameters	3-51
3-12 CLTU-THROW-EVENT Parameters	3-55
3-13 CLTU-PEER-ABORT Parameters	3-59
4-1 Provider Behavior	4-7
4-2 Event Description References	4-10
4-3 Predicate Definitions	4-10
4-4 Boolean Flags	4-11
4-5 Compound Action Definitions	4-11
B-1 Production Status Changes and Notifications	B-2
B-2 Effect of Production Status on Operations	B-5

CONTENTS (continued)

<u>Table</u>		<u>Page</u>
C-1	Conformance Matrix for the FCLTU Service (Operations).....	C-1
C-2	Conformance Matrix for the FCLTU Service (Other Requirements).....	C-2
F-1	Throw Event Examples	F-1

1 INTRODUCTION

1.1 PURPOSE OF THIS RECOMMENDED STANDARD

This Recommended Standard defines the Forward Communications Link Transmission Unit (FCLTU) service in conformance with the transfer services specified in reference [1], *Cross Support Reference Model—Part 1: SLE Services*. The FCLTU service is a Space Link Extension (SLE) transfer service that enables a mission to send CLTUs to a spacecraft.

1.2 SCOPE

This Recommended Standard defines, in an abstract manner, the FCLTU service in terms of:

- a) the operations necessary to provide the transfer service;
- b) the parameter data associated with each operation;
- c) the behaviors that result from the invocation of each operation; and
- d) the relationship between, and the valid sequence of, the operations and resulting behaviors.

It does not specify:

- a) individual implementations or products;
- b) the implementation of entities or interfaces within real systems;
- c) the methods or technologies required to radiate data to a spacecraft and to acquire telemetry frames from the signals received from that spacecraft for extraction of the Operational Control Field;
- d) the methods or technologies required for communications; or
- e) the management activities necessary to schedule, configure, and control the FCLTU service.

1.3 APPLICABILITY

1.3.1 APPLICABILITY OF THIS RECOMMENDED STANDARD

This Recommended Standard provides a basis for the development of real systems that implement the FCLTU service. Implementation of the FCLTU service in a real system additionally requires the availability of a communications service to convey invocations and returns of FCLTU service operations between service users and providers. This Recommended Standard requires that such a communications service ensure that invocations and returns of operations are transferred:

- a) in sequence;

RECOMMENDED STANDARD FOR SLE FCLTU SERVICE

- b) completely and with integrity;
- c) without duplication;
- d) with flow control that notifies backpressure to the application layer in the event of congestion; and
- e) with notification to the application layer in the event that communications between the FCLTU service user and the FCLTU service provider are disrupted, possibly resulting in a loss of data.

It is the specific intent of this Recommended Standard to define the FCLTU service in a manner that is independent of any particular communications services, protocols, or technologies.

1.3.2 LIMITS OF APPLICABILITY

This Recommended Standard specifies the FCLTU service that may be provided by an SLE System for inter-Agency cross support. It is neither a specification of, nor a design for, real systems that may be implemented for the control and monitoring of existing or future missions.

1.4 RATIONALE

The goal of this Recommended Standard is to create a standard for interoperability between the tracking stations or ground data handling systems of various agencies and the users of forward services.

1.5 DOCUMENT STRUCTURE

1.5.1 DOCUMENT ORGANIZATION

This Recommended Standard is organized as follows:

- a) section 1 provides purpose, scope, applicability, and rationale of this Recommended Standard and lists definitions, nomenclature, conventions, and references used throughout the Recommended Standard;
- b) section 2 presents an overview of the FCLTU service including a functional description, the service management context, and protocol considerations;
- c) section 3 specifies the operations of the FCLTU service;
- d) section 4 specifies the dynamic behavior of the FCLTU service in terms of the state transitions of the FCLTU service provider;

- e) annex A is a formal specification of FCLTU service data types, using the Abstract Syntax Notation One (ASN.1);
- f) annex B explains the relationship of the FCLTU service provisioning on the production status and its dependency on the status of the forward space link channel.
- g) annex C provides a conformance matrix that defines what capabilities must be provided for an implementation to be considered compliant with this Recommended Standard;
- h) annex D lists all terms used in this document and identifies where they are defined;
- i) annex E lists all acronyms used within this document;
- j) annex F contains examples of usage of the CLTU-THROW-EVENT operation;
- k) annex G contains a list of informative references.

1.5.2 SLE SERVICES DOCUMENTATION TREE

This Recommended Standard is based on the architectural model for cross support defined in reference [1]. It expands upon the concept of an SLE transfer service as interactions between SLE Mission User Entities (MUEs) and an SLE transfer service provider for the purpose of providing the FCLTU service.

This Recommended Standard is part of a suite of documents specifying the SLE Services. The SLE Services constitute one of the three types of Cross Support Services:

- a) Part 1: SLE Services;
- b) Part 2: Ground Communications Services;
- c) Part 3: Ground Domain Services.

The basic organization of the SLE services documentation is shown in figure 1-1. The documents are described in the following paragraphs.

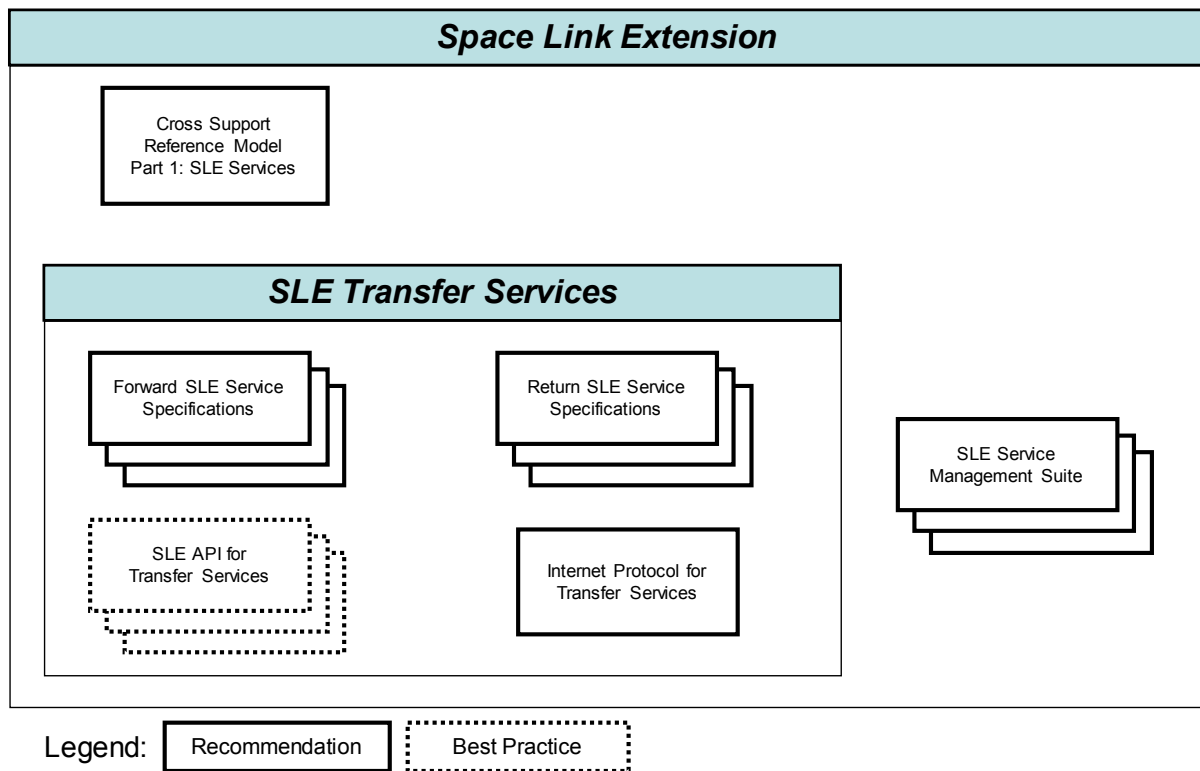

Figure 1-1: SLE Services Documentation

- a) *Cross Support Reference Model—Part 1: Space Link Extension Services* (reference [1]): a Recommended Standard that defines the framework and terminology for the specification of SLE services;
- b) *Return SLE Transfer Service Specifications*: a set of Recommended Standards that will provide specification of all return link SLE transfer services.
- c) *Forward SLE Transfer Service Specifications*: a set of Recommended Standards that will provide specification of all forward link SLE transfer services (this Recommended Standard is one of the specifications in that set);
- d) *SLE API for Transfer Services Specifications*: a set of Recommended Practices that provide specifications of an Application Program Interface and a mapping to Transmission Control Protocol/Internet Protocol (TCP/IP) as underlying communications service for SLE services;
- e) *Internet Protocol for Transfer Services* (reference [G5]): defines a protocol for transfer of SLE Protocol Data Units (PDUs) using TCP/IP as underlying communications service for SLE services;
- f) *SLE Service Management Specification Suite*: a set of Recommended Standards that establish the basis for SLE service management.

1.6 DEFINITIONS, NOMENCLATURE, AND CONVENTIONS

1.6.1 DEFINITIONS

1.6.1.1 Definitions from Open Systems Interconnection (OSI) Basic Reference Model

This Recommended Standard makes use of a number of terms defined in reference [7]. The use of those terms in this Recommended Standard shall be understood in a generic sense, i.e., in the sense that those terms are generally applicable to technologies that provide for the exchange of information between real systems. Those terms are:

- a) abstract syntax;
- b) application entity;
- c) application layer;
- d) application process;
- e) flow control;
- f) Open System Interconnection (OSI);
- g) real system;
- h) Service Access Point (SAP).

1.6.1.2 Definitions from Abstract Syntax Notation One

This Recommended Standard makes use of the following terms defined in reference [6]:

- a) Abstract Syntax Notation One (ASN.1);
- b) object identifier;
- c) (data) type;
- d) (data) value.

NOTE – In annex A of this Recommended Standard, ASN.1 is used for specifying the abstract syntax of the invocations and returns of the operations of the FCLTU service. The use of ASN.1 as a descriptive language is intended to support the specification of the abstract FCLTU service; this Recommended Standard does not levy a requirement for implementations to employ ASN.1 encoding rules. However, a separate Recommended Standard *Space Link Extension—Internet Protocol for Transfer Services* (reference [G5]), which specifies the set of encoding methods and communication protocols that have been approved by CCSDS for SLE transfer services for cross support, does specify a particular encoding method that is based on ASN.1.

1.6.1.3 Definitions from TC Synchronization and Channel Coding

This Recommended Standard makes use of the following terms defined in reference [2]:

- a) acquisition sequence;
- b) Communications Link Transmission Unit (CLTU);
- c) Carrier Modulation Mode (CMM);
- d) idle sequence;
- e) Physical Layer Operations Procedure (PLOP).

1.6.1.4 Definitions from TC Space Data Link Protocol

This Recommended Standard makes use of the following term defined in reference [3]:

Communications Link Control Word (CLCW).

1.6.1.5 Definitions from SLE Reference Model

This Recommended Standard makes use of the following terms defined in reference [1]:

- a) abstract binding;
- b) abstract object;
- c) abstract port;
- d) abstract service;
- e) CLTU channel;
- f) FCLTU service;
- g) invoker;
- h) Management Provider Service Port (M-P);
- i) Management User Service Port (M-U);
- j) Mission Data Operation System (MDOS);
- k) Mission User Entity (MUE);
- l) offline delivery mode;
- m) online delivery mode;
- n) operation;

RECOMMENDED STANDARD FOR SLE FCLTU SERVICE

- o) performer;
- p) physical channel;
- q) service agreement;
- r) service provider (provider);
- s) service user (user);
- t) SLE Complex;
- u) SLE Complex Management;
- v) SLE data channel;
- w) SLE functional group (SLE-FG);
- x) SLE Protocol Data Unit (SLE-PDU);
- y) SLE Service Data Unit (SLE-SDU);
- z) SLE service package;
- aa) SLE transfer service instance;
- bb) SLE transfer service production;
- cc) SLE transfer service provision;
- dd) SLE Utilization Management;
- ee) space link;
- ff) space link data channel;
- gg) space link data unit (SL-DU);
- hh) space link session;
- ii) Transfer Provider Service Port (T-P);
- jj) Transfer User Service Port (T-U).

1.6.1.6 Additional Definitions

For the purposes of this Recommended Standard, the following definitions also apply.

1.6.1.6.1 Association

An association is a cooperative relationship between an SLE service-providing application entity and an SLE service-using application entity. An association is formed by the exchange of SLE-PDUs through use of an underlying communications service.

1.6.1.6.2 Communications Service

A communications service is a capability that enables an SLE service-providing application entity and an SLE service-using application entity to exchange information.

NOTE – If an SLE service user and an SLE service provider are implemented using different communications services, then interoperability between them is possible only by means of a suitable gateway. Adherence to this Recommended Standard ensures, at least in principle, that it is possible to construct such a gateway.

1.6.1.6.3 Confirmed Operation

A confirmed operation is an operation that requires the performer to return a report of its outcome to the invoker.

1.6.1.6.4 Initiator

The initiator is the object that issues the request to bind to another object (the responder).

NOTE – In other words, the initiator is always the invoker of the request to bind to another object. Therefore, in the context of the request to bind, the terms ‘initiator’ and ‘invoker’ refer to the same object and are synonyms.

1.6.1.6.5 Invocation

The invocation of an operation is the making of a request by an object (the invoker) to another object (the performer) to carry out the operation.

1.6.1.6.6 Operational Control Field

The Operational Control Field (OCF) of a telemetry frame is the frame OCF of either a Telemetry (TM) Transfer Frame (reference [8]), or an Advanced Orbiting System (AOS) Transfer Frame (reference [9]), or a Unified Space Data Link Protocol (USLP) Transfer Frame (reference [10]). Depending on the configuration, service production of the FCLTU service may have to extract the CLCWs from the OCFs and evaluate them (see annex B for more information).

1.6.1.6.7 Parameter

A parameter of an operation is data that may accompany the operation's invocation or return.

NOTE – The term parameter is also used to refer to mission-dependent configuration information used in production or provision of the service.

1.6.1.6.8 Performance

The performance of an operation is the carrying out of the operation by an object (the performer).

1.6.1.6.9 Port Identifier

A port identifier identifies a source or a destination in a communications system.

NOTE – See 2.6.4.6 for more information.

1.6.1.6.10 Responder

The responder is the object that receives a request to bind and completes the binding (if possible) with the initiator in order for a service association to exist between the two objects.

NOTE – In other words, the responder is always the performer of the binding. Therefore, in the context of binding, the terms 'responder' and 'performer' refer to the same object and are synonyms.

1.6.1.6.11 Return

The return of an operation is a report, from the performer to the invoker, of the outcome of the performance of the operation.

1.6.1.6.12 Service Instance Provision Period

A service instance provision period is the time during which a service instance (i.e., the capability to transfer one or more SLE data channels of a given type) is scheduled to be provided.

1.6.1.6.13 Spacecraft Identifier

The spacecraft identifier (SCID) of a telemetry frame is as defined in reference [8] if the frame is a TM Transfer Frame, as defined in reference [9] if the frame is an AOS Transfer Frame, or as defined in reference [10] if the frame is a USLP Transfer Frame.

1.6.1.6.14 Transfer Frame Version Number

The Transfer Frame Version Number (TFVN) is either the TFVN as defined in reference [8], the TFVN as defined in reference [9], or the TFVN as defined in reference [10]. The definitions of TFVN given in references [8], [9], and [10] are equivalent. The TFVN enables one to distinguish between a TM Transfer Frame, an AOS Transfer Frame, and a USLP Transfer Frame.

1.6.1.6.15 Unconfirmed Operation

An unconfirmed operation is an operation that does not require a report of its outcome to be returned to the invoker by the performer.

1.6.2 NOMENCLATURE

The following conventions apply throughout this Recommended Standard:

- a) the words ‘shall’ and ‘must’ imply a binding and verifiable specification;
- b) the word ‘should’ implies an optional, but desirable, specification;
- c) the word ‘may’ implies an optional specification;
- d) the words ‘is’, ‘are’, and ‘will’ imply statements of fact.

1.6.3 CONVENTIONS

1.6.3.1 Specification of Operations

1.6.3.1.1 General

Section 3 of this Recommended Standard specifies the operations that constitute the FCLTU service. The specification of each operation is divided into subsections as follows:

1.6.3.1.2 Purpose Subsection

The Purpose subsection briefly describes the purpose and functioning of the operation. Additionally, it indicates whether the operation may be invoked by the user, provider, or both; whether the operation is confirmed or unconfirmed; and whether there are any constraints on when the operation may be invoked.

1.6.3.1.3 Invocation, Return, and Parameters Subsection

The Invocation, Return, and Parameters subsection describes the parameters associated with each operation, including their semantics. A table accompanying the description of each

operation lists all parameters associated with the operation and, for both the invocation and return, whether the parameter is always present, always absent, or conditionally present.

For parameters that are conditionally present, the parameter description specifies the conditions for the presence or absence of the parameter. The condition is generally based on the value of another parameter in the same invocation or return; for example, in the return of an operation, the `diagnostic` parameter is present if and only if the value of the `result` parameter is ‘negative result’. For a conditional parameter in a return, the condition may be based on the value of a parameter in the corresponding invocation.

In the table, the following convention is used to indicate whether a parameter is always present, always absent, or conditionally present:

M	always present (mandatory)
C	conditionally present
Blank	always absent

NOTE – Even though a parameter may be characterized as always present, its description may specify that its value is permitted to be ‘null’ or ‘unused’ or the like.

1.6.3.1.4 Effects Subsection

The Effects subsection describes the effects an operation has on the invoker, the performer, the association between them, or any combination thereof. The details of how those effects occur or the mechanisms used are outside the scope of this Recommended Standard.

1.6.3.2 Typographic Conventions

Typographic conventions used in this Recommended Standard are described in the following subsections.

1.6.3.2.1 Operation Names

Names of FCLTU service operations appear in uppercase and begin with the characters ‘CLTU-’ (e.g., CLTU-TRANSFER-DATA).

1.6.3.2.2 Parameter Names

In the main text, names of parameters of FCLTU service operations appear in lowercase and are typeset in a fixed-width font (e.g., `responder-port-identifier`). In annex A, the corresponding name is formed by omitting any hyphens contained in the name and using mixed-case (e.g., `responderPortIdentifier`).

1.6.3.2.3 Value Names

The values of many parameters discussed in this Recommended Standard are represented by names. In the main text, these names are shown in single quotation marks (e.g., 'no such service instance'). The corresponding name in annex A is formed by omitting any hyphens or white space contained in the name and using mixed-case (e.g., noSuchServiceInstance). The actual value associated with the name is constrained by the type of the parameter taking on this value. Parameter types are specified in annex A of this Recommended Standard.

NOTE – The name of a value does not imply anything about its type. For example, the value 'no such service instance' has the appearance of a character string but might be assigned to a parameter whose type is integer.

1.6.3.2.4 State Names

This Recommended Standard specifies the states of FCLTU service providers. States may be referred to by number (e.g., state 3) or by name. State names are always shown in single quotation marks (e.g., 'active').

1.6.3.2.5 SLE-PDU Names

The names of SLE-PDUs appear in mixed-case (e.g., cltuBindInvocation).

1.6.3.2.6 Data Type Definitions

Data type definitions for the FCLTU service are presented in annex A in the form of a set of ASN.1 modules. Regardless of the conventions used elsewhere in this Recommended Standard, the text of the ASN.1 modules is typeset entirely in a fixed-width font.

1.6.3.3 Other Conventions

This Recommended Standard uses the conventions specified in reference [1].

1.7 REFERENCES

The following documents contain provisions which, through reference in this text, constitute provisions of this Recommended Standard. At the time of publication, the editions indicated were valid. All documents are subject to revision, and users of this Recommended Standard are encouraged to investigate the possibility of applying the most recent editions of the documents indicated below. The CCSDS Secretariat maintains a register of currently valid CCSDS Recommended Standards.

NOTES

- 1 A list of informative references is provided in annex G.
 - 2 This document takes advantage of the harmonized terminology introduced by restructured documentation of the space link protocols (references [2], [3], and [4]). From an interoperability point of view, they do not introduce any incompatibilities with respect to the original set of space link protocol documents (references [G1], [G2], [G3], and [G4]).
- [1] *Cross Support Reference Model—Part 1: Space Link Extension Services*. Issue 2. Recommendation for Space Data System Standards (Blue Book), CCSDS 910.4-B-2. Washington, D.C.: CCSDS, October 2005.
 - [2] *TC Synchronization and Channel Coding*. Issue 4. Recommendation for Space Data System Standards (Blue Book), CCSDS 231.0-B-4. Washington, D.C.: CCSDS, July 2021.
 - [3] *TC Space Data Link Protocol*. Issue 4. Recommendation for Space Data System Standards (Blue Book), CCSDS 232.0-B-4. Washington, D.C.: CCSDS, October 2021.
 - [4] *Communications Operation Procedure-1*. Issue 2. Recommendation for Space Data System Standards (Blue Book), CCSDS 232.1-B-2. Washington, D.C.: CCSDS, September 2010.
 - [5] *Time Code Formats*. Issue 4. Recommendation for Space Data System Standards (Blue Book), CCSDS 301.0-B-4. Washington, D.C.: CCSDS, November 2010.
 - [6] *Information Technology—Abstract Syntax Notation One (ASN.1): Specification of Basic Notation*. 4th ed. International Standard, ISO/IEC 8824-1:2008. Geneva: ISO, 2008.
 - [7] *Information Technology—Open Systems Interconnection—Basic Reference Model: The Basic Model*. 2nd ed. International Standard, ISO/IEC 7498-1:1994. Geneva: ISO, 1994.
 - [8] *TM Space Data Link Protocol*. Issue 3. Recommendation for Space Data System Standards (Blue Book), CCSDS 132.0-B-3. Washington, D.C.: CCSDS, October 2021.
 - [9] *AOS Space Data Link Protocol*. Issue 4. Recommendation for Space Data System Standards (Blue Book), CCSDS 732.0-B-4. Washington, D.C.: CCSDS, October 2021.
 - [10] *Unified Space Data Link Protocol*. Issue 2. Recommendation for Space Data System Standards (Blue Book), CCSDS 732.1-B-2. Washington, D.C.: CCSDS, October 2021.

2 DESCRIPTION OF THE FCLTU SERVICE

2.1 OVERVIEW

The FCLTU service enables the user of the service to send CLTUs to a spacecraft via an established forward space link channel. A forward space link channel is a physical channel carrying an asynchronous stream of CLTUs (reference [1]).

The service user submits CLTUs, encapsulated in SLE-SDUs, by means of the CLTU-TRANSFER-DATA operation. Production of the FCLTU service by the provider entails processing the CLTUs transferred by the user through the necessary transformations to modulate the Radio Frequency (RF) carrier channel providing uplink communications with the spacecraft.

The FCLTU service transmits the CLTUs in the order in which they are submitted by the service user. The provider may perform checks to determine if the CLTU complies with applicable constraints, e.g., that the length of the CLTU is within the maximum size set by service management. However, the provider does not interpret, interrogate, or modify the contents of a CLTU. CLTUs are transmitted bit for bit as received from the service user.

CLTUs may or may not conform to the format defined in reference [2]. The FCLTU service may be used to uplink any octet-aligned bit pattern.

The operations defined in section 3 of this Recommended Standard enable a single FCLTU service user to interact with an FCLTU service provider to:

- a) establish an association between the user and the provider;
- b) send annotated CLTUs to the provider;
- c) obtain notifications and reports regarding status, configuration, and performance of the service;
- d) temporarily stop and later re-start the sending of CLTUs;
- e) release an association.

The FCLTU service is provided only in the online delivery mode, as defined in reference [1]. The offline delivery mode is the subject of further study.

The provision of FCLTU service for access to one physical channel by one service user constitutes one instance of service. Only a single service instance of the FCLTU service may exist per physical channel at a time.

2.2 SPACE LINK EXTENSION REFERENCE MODEL

2.2.1 INTRODUCTION

The FCLTU service is specified within the framework defined by the SLE Reference Model (reference [1]). The following subsections summarize selected concepts from that model.

2.2.2 ABSTRACT OBJECT

An abstract object is a functional entity that interacts with other abstract objects. Objects are of different types, which determine their function and behavior. An object is characterized by its interfaces (one or more), which are called abstract ports, and the operations that are made available through those interfaces.

2.2.3 ABSTRACT SERVICE

An abstract service is the capability provided by a set of operations that an abstract object exposes at one or more of its abstract ports.

NOTE – The concept of an abstract service is to be distinguished from the concept of an (N)-service as defined in the OSI Basic Reference Model (reference [7]). The definition of (N)-service is in terms of the capability provided by one layer in the OSI architecture to the layer above it. The definition of abstract service is in terms of the capability provided by one abstract object to another abstract object. In a cross support scenario, where one Agency is providing an SLE service to another Agency, the object that provides the service typically is associated with one Agency, and the object that uses the service typically is associated with the other Agency.

2.2.4 ABSTRACT BINDING

When two abstract ports have an association established between them, they are said to be bound. The act of establishing such an association is called abstract binding. One object (the initiator) invokes a bind operation which is accepted (or rejected) by another object (the responder).

2.2.5 SERVICE USER/PROVIDER

An object that offers a service to another by means of one or more of its ports is called a service provider (provider). The other object is called a service user (user). An object may be a provider of some services and a user of others.

The terms user and provider are used to distinguish the roles of two interacting objects. In this Recommended Standard, when two objects are involved in provision of a service, the

object closer to the space link is considered to be the provider of the service, and the object further from the space link is considered to be the user.

2.2.6 OPERATION

An operation is a procedure or task that one object (the invoker) can request of another (the performer) through a bound port pair.

The terms invoker and performer are used to describe the interaction between two objects as the operations that constitute the service occur. One object invokes an operation that is performed by the other. For most services, each object invokes some operations and performs others.

2.3 SERVICE MANAGEMENT

SLE service management determines the number and schedule of FCLTU service instances to be provided, the resources required to enable those service instances, and the initial configuration of all service instances and their supporting resources. SLE service management is the subject of separate CCSDS Recommended Standards.

The SLE Reference Model (reference [1]) distinguishes between service provision and service production:

- a) service provision makes available to the user the operations necessary to obtain the service;
- b) service production transforms the FCLTU data channel to the RF carrier channel.

Certain configuration parameters are associated with provision of FCLTU service while others are associated with production. Configuration parameters that are associated with the production, such as bit rate and modulation index, can potentially impact SLE Complex resources. Consequently, only service management may modify production configuration parameter values. The FCLTU service user may modify some provision configuration parameters through operations specified in this Recommended Standard.

If so agreed between the service providing SLE complex and the service using MUE, modification of service production parameters can be achieved by using the CLTU-THROW-EVENT operation (see 3.11).

2.4 ARCHITECTURE MODEL – FUNCTIONAL VIEW

2.4.1 FORWARD TC SPACE LINK PROCESSING SLE FUNCTIONAL GROUP

The Forward Telecommand (TC) Space Link Processing SLE Functional Group (SLE-FG) (shown in figure 2-1) produces the FCLTU service.

RECOMMENDED STANDARD FOR SLE FCLTU SERVICE

As described in reference [1], the Forward TC Space Link Processing SLE-FG consumes one CLTU data channel consisting of a stream of CLTU SLE-SDUs. The SLE-SDUs that encapsulate the CLTUs contain control and annotation data that specify radiation time and other parameters to aid in processing the data (see 3.6). The Forward TC Space Link Processing SLE-FG uses these data to extract the CLTUs and inject them into the asynchronous physical channel.

NOTE – Per physical forward channel, only a single instance of the FCLTU service is supported at any point in time.

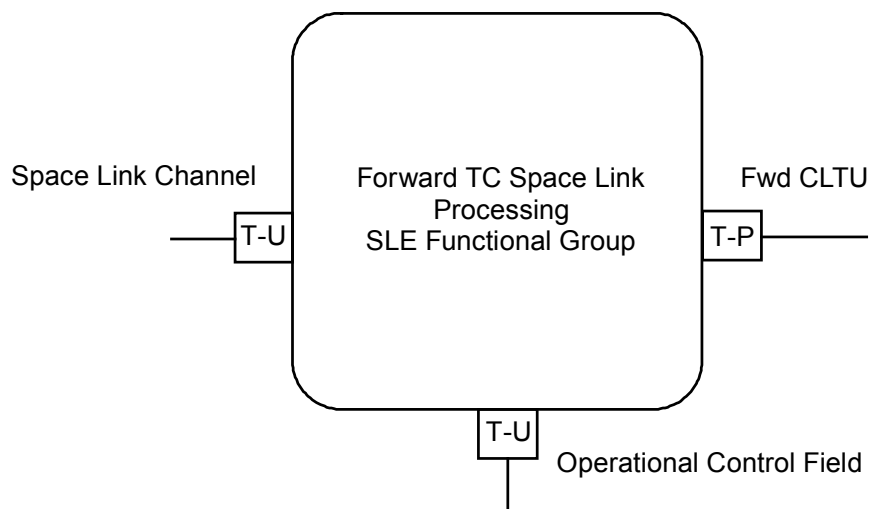

Figure 2-1: Forward TC Space Link Processing SLE-FG

The Forward TC Space Link Processing SLE-FG performs the following functions with respect to the FCLTU service:

- a) consumes one CLTU data channel and extracts CLTUs encapsulated in SLE-SDUs;
- b) consumes one OCF data channel and extracts the CLCWs. Based on the values in the CLCWs, the FCLTU service determines whether the physical channel is available;

NOTES

- 1 CLCWs may be ignored, as an option set by Service Management. See 3.1.9 and table 3-11.
- 2 The CLCWs are to be extracted from the OCFs received via the appropriate telemetry channel, where the details in terms of necessary service production vary depending on the telemetry frame format. At the time of this writing, reference [1] does not cover the handling of USLP Transfer Frames, but a future version of that document is expected to do so. Details regarding the processing of USLP Transfer Frames may be found in reference [10].

- c) performs the following:
- 1) generates the acquisition sequence and idle sequence on the physical channel in accordance with the PLOP in effect;
 - 2) utilizes the underlying antenna steering capabilities provided by the ground element;
 - 3) modulates the CLTUs as a stream of bits on the ground-to-space RF channel; and
 - 4) radiates the signal to the spacecraft.

2.4.2 FCLTU SERVICE PRODUCTION AND PROVISION

FCLTU **production** is concerned with radiating CLTUs extracted from a stream of SLE-SDUs according to the CLTU control and annotation information in the SLE-SDU and according to the configuration set up by service management. FCLTU service **provision** is concerned with receiving a stream of SLE-SDUs from an FCLTU service user. Service provision addresses such matters as when service is provided (e.g., service start and stop times), and how service is provided (e.g., which events are notified to the user).

The SLE-SDUs consumed by the FCLTU service are sent by the service user by means of the FCLTU service operations defined in section 3. These operations also provide additional functionality to facilitate the provision of service, i.e., enabling the exchange of SLE-SDUs across a remote interface. The service operations are realized as SLE-PDUs which are exchanged between the FCLTU service provider and the FCLTU service user by means of an underlying communications service. The general relationship between SL-DUs, SLE-SDUs, and SLE-PDUs is illustrated in figure 2-2.

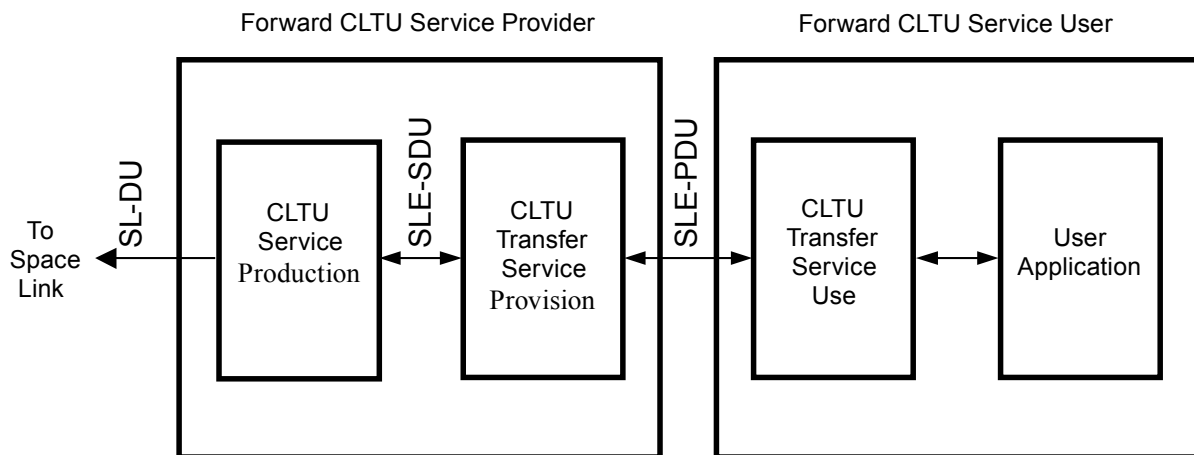

Figure 2-2: FCLTU Service Production and Provision

Production of the FCLTU service by the provider occurs during the space link session; in general, service production will largely overlap with service provision. Production status affects the provision of the service, as specified in sections 3 and 4, and reviewed in annex B.

2.5 ARCHITECTURE MODEL – CROSS-SUPPORT VIEW

The management and control of the production and provision of the SLE transfer services is described in general terms in reference [1]. Figure 2-3 shows an example operational scenario and the related binding of the FCLTU service ports and SLE management ports. This example shows an SLE Complex with one Forward Space Link Processing SLE-FG instance; it is providing one instance of FCLTU service to an MDOS. As this figure shows, only a single Mission User Entity can use the FCLTU service provided by a single Forward Space Link Processing SLE-FG.

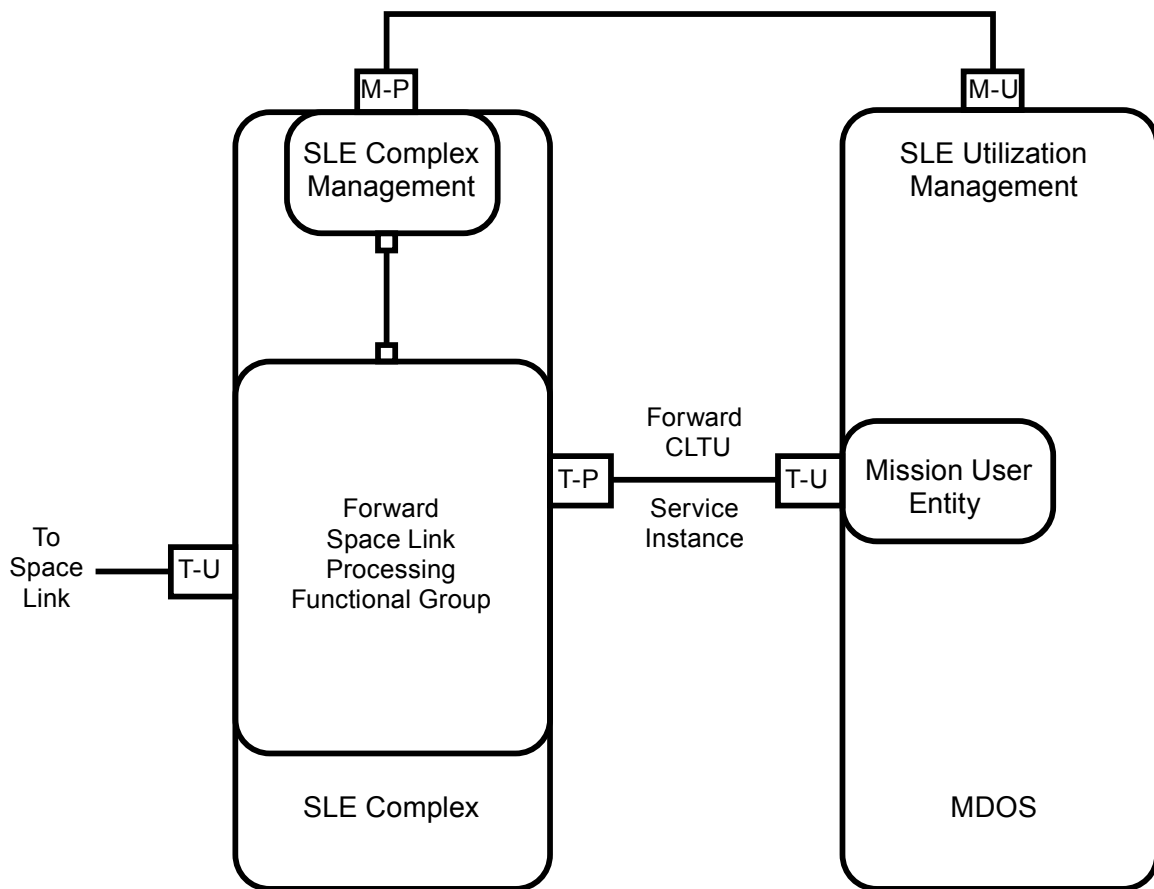

Figure 2-3: Example of Management and Provision of FCLTU Service

2.6 FUNCTIONAL DESCRIPTION

2.6.1 GENERAL

This subsection describes the FCLTU service with respect to scheduling, configuration, underlying services, provider states and protocol considerations.

2.6.2 SCHEDULING AND CONFIGURATION

SLE Utilization Management negotiates with SLE Complex Management to establish mutually agreed upon SLE service packages. Among other things, SLE service packages specify what service instances are to be provided, when those services are to be provided, and what resources are needed to enable those services.

Service packages also specify the initial values of the mission-dependent parameters required for service production and provision. FCLTU service production parameters include such things as bit rate, modulation index, and subcarrier frequency. Provision parameters include such things as scheduled start and stop times of the FCLTU service instance.

Service production is guaranteed to occur only as needed to support service packages that have been scheduled and mutually agreed upon by SLE Complex Management and SLE Utilization Management. Service provision occurs only within the bounds of the agreed upon schedule of service instances and only during those periods when there is an association between the service provider and the service user.

2.6.3 UNDERLYING SERVICES

The CLTU service does not depend on any other SLE transfer service. Provision of the FCLTU service does depend on:

- a) service management for scheduling, resources, and configuration; the schedule for an FCLTU service instance must be compliant with the schedule of the underlying equipment such as antennas, etc. The FCLTU service relies on service management actions for establishment of the space link, management of the PLOP and, when possible, recovery from production interruption;
- b) the availability of a suitable communications service to enable the exchange of information between the FCLTU service user and provider; and
- c) the functioning of FCLTU production resources (e.g., modulator(s), up-converter) to produce the forward physical channel.

2.6.4 PROTOCOL DESCRIPTION

2.6.4.1 FCLTU Operations

The operations that constitute the FCLTU service are listed in table 2-1. Section 3 of this Recommended Standard contains the detailed specification of these operations.

Table 2-1: FCLTU Service Operations

Service Operation	Invoked By	Purpose	Con- firmed
CLTU-BIND	Initiator (User)	To establish an association with the provider	Yes
CLTU-UNBIND	Initiator (User)	To release an association previously established by a CLTU-BIND operation	Yes
CLTU-START	User	To request that the SLE service provider prepare to accept CLTU-TRANSFER-DATA operations	Yes
CLTU-STOP	User	To request that the SLE service provider stop service provision and production.	Yes
CLTU-TRANSFER-DATA	User	To transfer a CLTU to the service provider	Yes
CLTU-ASYNC-NOTIFY	Provider	To notify the user of an event affecting production or provision of the FCLTU service	No
CLTU-SCHEDULE-STATUS-REPORT	User	To request that the provider send a status report immediately or periodically, or stop reporting	Yes
CLTU-STATUS-REPORT	Provider	To send a status report to the user	No
CLTU-GET-PARAMETER	User	To ascertain the value of an SLE service parameter (see table 3-11)	Yes
CLTU-THROW-EVENT	User	To forward an event that requires Complex Management to take the actions defined for this event	Yes
CLTU-PEER-ABORT	User or Provider	To notify the peer system that the local system detected an error that requires the association to be terminated	No

2.6.4.2 States of the Service Provider

Once an FCLTU service instance is created, the FCLTU service provider is in one of three states, as follows:

RECOMMENDED STANDARD FOR SLE FCLTU SERVICE

- a) State 1 ('unbound'): In state 1, all resources required to enable the provision of the FCLTU service have been allocated, and all objects required to provide the service have been instantiated. However, no association yet exists between the user and the provider (i.e., the FCLTU service provider port is not bound).
- b) State 2 ('ready'): In state 2, an association has been established between the user and the provider, and they may interact by means of the operations described in section 3 of this Recommended Standard. However, sending of CLTUs from the user to the provider (by means of the CLTU-TRANSFER-DATA operation) is not permitted. The user may enable the delivery of CLTUs by means of the appropriate service operation (CLTU-START), which, in turn, will cause the provider to transition to state 3 ('active').
- c) State 3 ('active'): State 3 resembles state 2 ('ready'), except that now the user can send CLTUs and the provider is enabled to radiate CLTUs to the spacecraft. The service continues in this state until the user invokes the CLTU-STOP operation to cause the provider to suspend transmission of CLTUs and transition back to state 2 or the CLTU-PEER-ABORT operation is invoked either by the user or the provider in which case the provider transitions to state 1.

A simplified state transition diagram for the FCLTU service provider is shown in figure 2-4. A detailed state transition matrix is provided in 4.2.

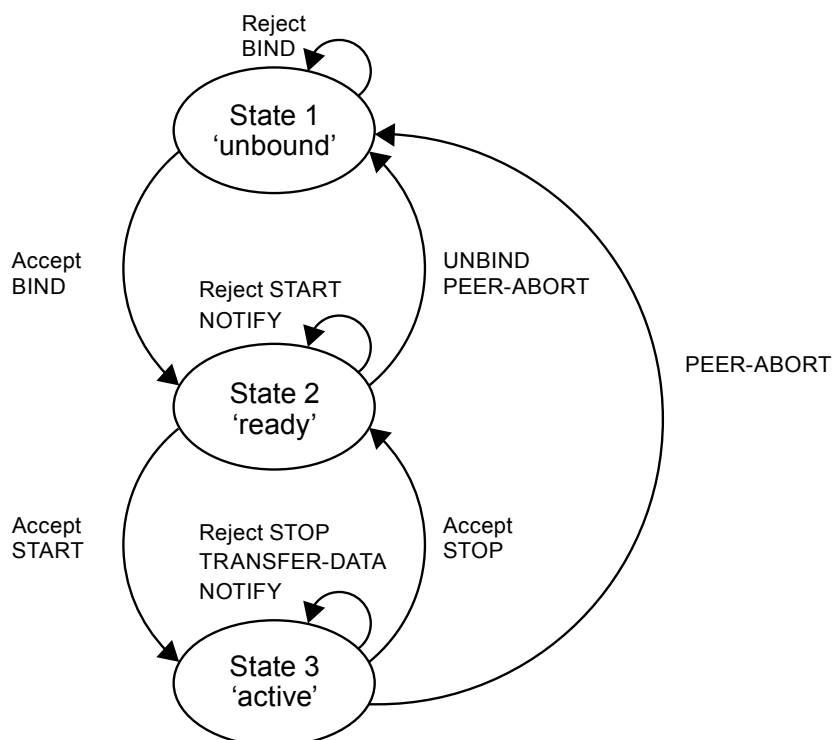

Figure 2-4: Simplified FCLTU Service Provider State Transition Diagram

2.6.4.3 Terminating an Association

An association is released normally when a CLTU-UNBIND is issued by the user (the initiator of the association) and accepted by the provider (the responder). An association may be aborted by either the user or the provider by means of the CLTU-PEER-ABORT operation. An association may also be aborted because of a failure in the underlying communications system. Such failures are signaled to the local application entity by the ‘protocol abort’ event described in 4.1.5.

2.6.4.4 Effects of Association Termination

When an association is released or aborted, where the CLTU-PEER-ABORT may be invoked either by the service user or locally by the service provider, the invocation of further operations by the user or the provider is not permitted. As a consequence, the production of CLTUs stops immediately following the termination of an association, except for a CLTU in the process of being radiated. Any buffered CLTUs are discarded. The only exception to this occurs when the association is terminated due to a protocol abort, and the protocol-abort-mode has been set to ‘continue’; in this case, production of CLTUs continues, and buffered CLTUs are not discarded.

The systems may re-establish an association via a new CLTU-BIND operation, if that is consistent with the schedule for provision of service. Status information is not preserved after an association terminates and is not available to the new association with the following exceptions:

- a) statistics reported by means of the CLTU-STATUS-REPORT operation, such as the number of CLTUs processed (see 3.9), shall be accumulated for the entire service instance provision period;
- b) parameters that serve to relate notifications on an activity to operations that triggered this activity will not be altered when the association is released or aborted.

2.6.4.5 Technology-specific Aspects

This Recommended Standard defines the FCLTU service. Provision of the FCLTU service in a real system also requires a specification of how the service is mapped to a communications service, such that all invocations and returns of the FCLTU service operations can be conveyed between the user and the provider. In order not to restrict the applicability of this Recommended Standard to a specific communications technology, as few assumptions as possible have been made about the characteristics of the underlying communications service (see 1.3.1).

The service interface between the user and the provider is specified in this Recommended Standard in terms of the operations that the service provides. Those operations are realized by mapping the service operation invocations and returns to PDUs that can be conveyed by

means of the underlying communications service. This Recommended Standard conceptualizes such mapping in two parts:

- a) FCLTU service operation invocations and returns (defined in section 3) are mapped to SLE-PDUs (defined in annex A);
- b) SLE-PDUs are mapped to PDUs that can be conveyed by means of the underlying communications service.

The mapping of FCLTU service operation invocations and returns to SLE-PDUs is specified by this Recommended Standard. The mapping of SLE-PDUs to an underlying communications service is intentionally outside the scope of this Recommended Standard (e.g., so that the FCLTU service may be mapped to more than one communications technology). In order to achieve interoperability, the user and provider must conform not only to this Recommended Standard but also to an agreed upon specification of the mapping of the FCLTU service to the underlying communications service. The specification of a mapping of the FCLTU service onto a particular communications service must address such points as:

- a) selection of communications network(s) to ensure connectivity;
- b) compatible configuration of protocol stacks (e.g., timeout values);
- c) specification of port-identifiers, and their translation onto the communications technology;
- d) specification of security related information.

Figure 2-5 illustrates a communications realization of the FCLTU service that results from such a mapping. The specification of such mappings is the subject of separate CCSDS Recommended Standards (e.g., reference [G5]).

Because the operations of the FCLTU service are relatively simple, once an association is in place between the service user and the service provider, the technology specific elements involved in the exchange of SLE-PDUs are generally minor. However, the way an association is established (i.e., the binding) tends to vary significantly depending on the communications technology in use. Nonetheless, the CLTU-BIND and CLTU-UNBIND operations as specified in this document are intended to be ‘technology neutral’. This neutrality is achieved as described in the following paragraphs.

For purposes of the communications mapping, the endpoints of an SLE association are identified by port identifiers, namely, an ‘initiator port identifier’ and a ‘responder port identifier’. The port identifiers represent all the technology-specific addressing information needed to establish communications between the user and provider and to route SLE-PDUs between them. The initiator port identifier identifies the endpoint that will invoke the CLTU-BIND operation (initiator). The responder port identifier identifies the endpoint that will perform the CLTU-BIND operation (responder). Generally speaking, the information represented by a port identifier consists of:

RECOMMENDED STANDARD FOR SLE FCLTU SERVICE

- a) information needed to route data between two real systems over a communications channel or network; and
- b) information needed to route data within a real system to a particular application entity.

For example, the information represented by a port identifier might be the combination of an Internet Protocol (IP) network address and a Transmission Control Protocol (TCP) port number or the combination of an OSI network address and an associated set of SAPs.

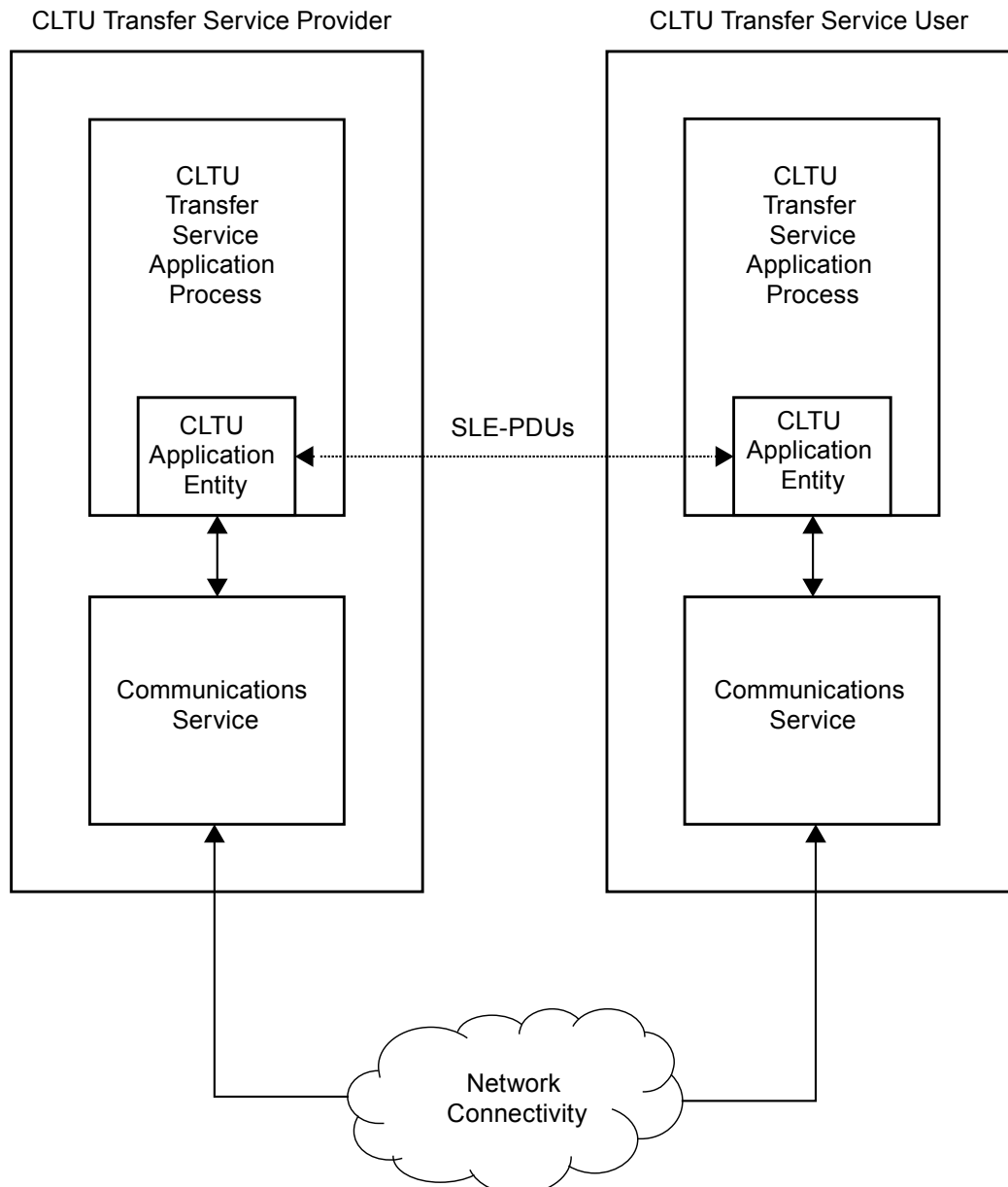

Figure 2-5: Communications Realization of FCLTU Service

The exact relationship between SLE port identifiers and communications ports provided by the underlying communications service must be specified by the mapping of the FCLTU service to the underlying communications service.

Reference [G5], which specifies the set of encoding methods and communication protocols that have been approved by CCSDS for SLE transfer services for cross support, maps SLE transfer services to the TCP/IP communications service. Depending on the chosen mapping, also issues such as sizing of TCP buffers in accordance with the bandwidth-delay product of the communication link and ways to manage relative priority of transfer services concurrently using the same connectivity are to be addressed. These aspects are a local matter and not addressed in reference [G5].

In order for an SLE association to be established, SLE Complex Management and SLE Utilization Management must agree beforehand on the responder port identifier for the association. The responder needs the information represented by the responder port identifier to ensure that resources are allocated to recognize and respond to a CLTU-BIND invocation for that association. The initiator needs the information to ensure that the CLTU-BIND invocation will be communicated to the appropriate responder.

In general, it is not necessary for SLE Complex Management and SLE Utilization Management to agree beforehand on the initiator port identifier for the association. Rather, the initiator should communicate that information to the responder in conjunction with the CLTU-BIND invocation. The exact means by which the initiator port identifier is provided to the responder is technology-specific and must be specified by the mapping of the FCLTU service to the underlying communications service.

The responder port identifier is included as a parameter of the CLTU-BIND operation. While it is only necessary that the SLE application entity communicate the information represented by the port identifiers to the underlying communications service, the responder port identifier is provided as a parameter of the CLTU-BIND operation to allow for the possible simplification of the implementation of a gateway.

The information represented by the responder port identifier is technology-specific. In order to define the CLTU-BIND operation in a way that is not technology-specific, the `responder-port-identifier` parameter of the CLTU-BIND operation is defined to be a logical name. A logical name is an arbitrary identifier that has an appropriately chosen and agreed upon translation to technology-specific information. Prior to the start time of a service instance, SLE Complex Management and SLE Utilization must mutually agree upon the value of the responder port identifier (and its translation) applicable to that service instance. The actual process of translating logical names to technology-specific information is considered a local matter. The translation methodology may rely on simple techniques such as look-up tables or may use more elaborate mechanisms such as naming or directory services.

The above discussion describes the case that both the user and provider applications are implemented using the same communications service. It is possible to achieve

interoperability even if the user and provider use different communications services. However, in that case interoperability requires the use of an appropriate gateway.

2.6.4.6 Buffering

The FCLTU service buffers the CLTUs for the primary purpose of maintaining radiation of a steady stream of CLTUs despite variable latency over the ground communications channel. All transfers of CLTUs from the service user to the service provider must occur within the scheduled service instance provision period.

2.7 OPERATIONAL SCENARIO

Prior to the actual provision of service, start and stop times for both the space link session and the associated FCLTU service instance are negotiated between SLE Complex Management and SLE Utilization Management. Configuration and other information needed to enable the service are also agreed.

Some time before the scheduled start time of the FCLTU service instance, the service instance is created by SLE Complex Management. Initially, the service provider is in state 1 ('unbound'). At the scheduled start time of the space link session, the SLE Complex establishes the forward link to the spacecraft and initiates the production of FCLTU service. Typically (but not necessarily) the start time of the service instance will precede by a small margin the start time of the space link session to allow the user to bind to the service before the start of the space link session.

The following illustrates a typical sequence of operations between the user and the provider of the FCLTU service. A complete definition of the operations is found in section 3; the formal specification of provider behavior is presented in section 4.

- a) The user invokes the CLTU-BIND operation to establish an association.
- b) The provider, when configured to monitor uplink status by examining the No RF Available and/or No Bit Lock flags returned from the spacecraft in the CLCW, performs the necessary operations to receive the OCFs as provided by the Return Frame Processing SLE-FG.

NOTE – At the time of this writing the specification of the Return Frame Processing SLE-FG provided in reference [1] does not cover the processing of USLP Transfer Frames for the extraction of OCFs and the CLCWs contained therein. A future version of reference [1] is expected to do so. However, reference [10] specifies the receiving-end procedure for USLP Transfer Frames and thus provides the information missing in reference [1].

- c) The provider monitors equipment readiness, the status of the physical channel and (when configured to do so) the uplink status. When `production-status` changes to 'operational' the provider sends CLTU-ASYNC-NOTIFY to the user.

NOTE – Modulation of the uplink signal with acquisition sequence and idle sequence, in accordance with the PLOP in effect, is under the control of service management. Related details can be found in annex B.

- d) The user sends CLTU-START, and the provider transitions to state 3, ‘active’.
- e) The user sends a CLTU-TRANSFER-DATA operation to the provider. The provider verifies the invocation, and if acceptable, buffers the CLTU until the specified `earliest-radiation-time` is reached.
- f) Additional CLTUs may be sent by the user and will be buffered by the provider.

NOTE – The user may perform steps, d), e) and f), invoking CLTU-START and CLTU-TRANSFER-DATA, before `production-status` becomes ‘operational’ as described in step c).

- g) At the time specified for start of radiation, if `production-status` is ‘operational’, the first CLTU is injected into the physical channel and modulated onto the RF carrier. The signal is radiated to the spacecraft. If no `earliest-radiation-time` was specified in the CLTU-TRANSFER-DATA operation, the CLTU is radiated as soon as received, or whenever `production-status` becomes ‘operational’, if that is later.
- h) Successive CLTUs are processed in similar fashion after the `delay-time` (if any) specified in the preceding CLTU is satisfied.
- i) The user transfers the last CLTU to the provider.
- j) The provider completes processing the buffered CLTUs. When the provider’s CLTU buffer is empty, it sends CLTU-ASYNC-NOTIFY to inform the user.
- k) The user sends CLTU-STOP and the provider transitions to state 2, ‘ready’.
- l) The user performs CLTU-UNBIND to release the association.

2.8 SECURITY ASPECTS OF THE FCLTU SERVICE

2.8.1 SECURITY BACKGROUND/INTRODUCTION

The SLE transfer services explicitly provide authentication and access control. Additional security capabilities, if required, are levied on the underlying communications services that support the SLE transfer services. The SLE transfer services are defined as layered application services operating over underlying communications services that must meet certain requirements but which are otherwise unspecified. Selection of the underlying communications services over which real SLE implementations connect is based on the requirements of the communicating parties and/or the availability of CCSDS-standard communication technology profiles and proxy specifications. Different underlying communication technology profiles are intended to address not only different performance

requirements but also different security requirements. Missions and service providers are expected to select from these technology profiles to acquire the performance and security capabilities appropriate to the mission. Specification of the various underlying communication technologies, and in particular their associated security provisions, are outside the scope of this Recommended Standard.

The FCLTU service transfers data that is destined for a mission spacecraft. As such, the FCLTU service has custody of the data for only a portion of the end-to-end data path between MDOS and mission spacecraft. Consequently the ability of an SLE transfer service to secure the transfer of mission spacecraft data is limited to that portion of the end-to-end path that is provided by the SLE transfer service (i.e., the terrestrial link between the MDOS and the ground termination of the ground-space link to the mission spacecraft). End-to-end security must also involve securing the data as it crosses the ground-space link, which can be provided by some combination of securing the mission data itself (e.g., encryption of the mission data within CCSDS space packets) and securing the ground-space link (e.g., encryption of the physical ground-space link). Thus while the FCLTU service plays a role in the end-to-end security of the data path, it does not control and cannot ensure that end-to-end security. This component perspective is reflected in the security provisions of the SLE transfer services.

2.8.2 STATEMENTS OF SECURITY CONCERNS

2.8.2.1 Introduction

This subsection identifies FCLTU service support for capabilities that responds to these security concerns in the areas of data privacy, data integrity, authentication, access control, availability of resources, and auditing.

2.8.2.2 Data Privacy (also known as Confidentiality)

This FCLTU service specification does not define explicit data privacy requirements or capabilities to ensure data privacy. Data privacy is expected to be ensured outside of the SLE transfer service layer, by the mission application processes that communicate over the SLE transfer service, in the underlying communications service that lies under the SLE transfer service, or some combination of both. For example, mission application processes might apply end-to-end encryption to the contents of the CCSDS space link data units carried as data by the SLE transfer service. Alternatively or in addition, the network connection between the SLE entities might be encrypted to provide data privacy in the underlying communication network.

2.8.2.3 Data Integrity

The FCLTU service requires that each transferred CLTU be accompanied by a sequence number (`cltu-identification`), which must increase monotonically. Failure of a CLTU to be accompanied by the expected sequence number causes that CLTU to be rejected (see 3.6.2.13.1 d)). This constrains the ability of a third party to inject additional command data into an active FCLTU service instance.

The FCLTU service defines and enforces a strict sequence of operations that constrain the ability of a third party to inject operation invocations or returns into the transfer service association between a service user and provider (see 4.2.2). This constrains the ability of a third party to seize control of an active FCLTU service instance without detection.

The FCLTU service requires that the underlying communications service transfer data in sequence, completely and with integrity, without duplication, with flow control that notifies the application layer in the event of congestion, and with notification to the application layer in the event that communication between the service user and the service provider is disrupted (see 1.3.1). No specific mechanisms are identified, as they will be an integral part of the underlying communications service.

2.8.2.4 Authentication

This FCLTU service specification defines authentication requirements (see 3.1.5 and 4.1.7), and defines `initiator-identifier`, `responder-identifier`, `invoker-credentials`, and `performer-credentials` parameters of the service operation invocations and returns that are used to perform SLE transfer service authentication. The procedure by which SLE transfer service operation invocations and returns are authenticated is described in reference [G5]. The SLE transfer service authentication capability can be selectively set to authenticate at one of three levels: authenticate every invocation and return, authenticate only the BIND operation invocation and return, or perform no authentication. Depending upon the inherent authentication available from the underlying communication network, the security environment in which the SLE service user and provider are operating, and the security requirements of the spaceflight mission, the SLE transfer service authentication level can be adapted by choosing the SLE operation invocation and returns that shall be authenticated. Furthermore the mechanism used for generating and checking the credentials and thus the level of protection against masquerading (simple or strong authentication) can be selected in accordance with the results of a threat analysis.

2.8.2.5 Access Control

This FCLTU service specification defines access control requirements (see 3.1.4 and 4.1.6), and defines `initiator-identifier` and `responder-identifier` parameters of the service operation invocations and returns that are used to perform SLE transfer service access control.

2.8.2.6 Availability of Resources

The SLE transfer services are provided via communication networks that have some limit to the resources available to support those SLE transfer services. If these resources can be diverted from their support of the SLE transfer services (in what is commonly known as ‘denial of service’) then the performance of the SLE transfer services may be curtailed or inhibited. This FCLTU service specification does not define explicit capabilities to prevent denial of service. Resource availability is expected to be ensured by appropriate capabilities in the underlying communications service. The specific capabilities will be dependent upon the technologies used in the underlying communications service and the security environment in which the transfer service user and provider operate.

2.8.2.7 Auditing

This FCLTU service specification does not define explicit security auditing requirements or capabilities. Security auditing is expected to be negotiated and implemented bilaterally between the spaceflight mission and the service provider.

2.8.3 POTENTIAL THREATS AND ATTACK SCENARIOS

The FCLTU service depends on unspecified mechanisms operating above the SLE transfer service (between a mission spacecraft application process and its peer application process on the ground), underneath the SLE transfer service in the underlying communications service, or some combination of both, to ensure data privacy (confidentiality). If no such mechanisms are actually implemented, or the mechanisms selected are inadequate or inappropriate to the network environment in which the mission is operating, an attacker could read the command data contained in the FCLTU PDUs as they traverse the Wide Area Network (WAN) between service user and service provider.

The FCLTU service constrains the ability of a third party to seize control of an active SLE transfer service instance, or to inject extra command data into a service instance, but it does not specify mechanisms that would prevent an attacker from intercepting the PDUs and replacing the contents of the `data` parameter. The prevention of such a replacement attack depends on unspecified mechanisms operating above the SLE transfer service (between a mission spacecraft application process and its peer application process on the ground), underneath the SLE transfer service in the underlying communications service, in bilaterally-agreed extra capabilities applied to the SLE transfer service (e.g., encryption of the `data` parameter) or some combination of the three. If no such mechanisms are actually implemented, or the mechanisms selected are inadequate or inappropriate to the network environment in which the mission is operating, an attacker could ‘hijack’ an established FCLTU service instance and overwrite the commands in the PDUs to subvert or destroy the operation of the spacecraft.

If the SLE transfer service authentication capability is not used and if authentication is not ensured by the underlying communications service, attackers may somehow obtain valid

`initiator-identifier` values and use them to initiate SLE transfer service instances by which they could subvert or destroy the mission.

■ The FCLTU service depends on unspecified mechanisms operating in the underlying communications service to ensure that the supporting network has sufficient resources to provide sufficient support to legitimate users. If no such mechanisms are actually implemented, or the mechanisms selected are inadequate or inappropriate to the network environment in which the mission is operating, an attacker could prevent legitimate users from communicating with their spacecraft, causing degradation or even loss of the mission.

■ If the provider of the FCLTU service provides no security auditing capabilities, or if a user chooses not to employ auditing capabilities that do exist, then attackers may delay or escape detection long enough to do serious (or increasingly serious) harm to the mission.

2.8.4 CONSEQUENCES OF NOT APPLYING SECURITY

■ The consequences of not applying security to the FCLTU service are possible degradation and loss of ability to command the spacecraft, and even loss of the spacecraft itself.

3 FCLTU SERVICE OPERATIONS

NOTE – This section (3) specifies the processing of valid SLE-PDUs (i.e., those that are recognized as the invocation or return of a FCLTU service operation). Subsection 3.1 specifies behaviors that are generally applicable to all operations. Subsections 3.2 through 3.12 specify individual operations. Handling of invalid SLE-PDUs is specified in subsection 4.1.

3.1 GENERAL CONSIDERATIONS

3.1.1 RESULT OF OPERATIONS

3.1.1.1 All confirmed operations shall report on the outcome of the operation in a return, except as specified otherwise in section 4.

3.1.1.2 All returns shall include a `result` parameter that indicates whether the outcome of the operation was successful (`result` is ‘positive result’) or unsuccessful (`result` is ‘negative result’).

3.1.1.3 In the event of `result` is ‘negative result’, the return shall also include a `diagnostic` parameter that is descriptive of the reason for the ‘negative result’.

NOTE – Possible values of the `diagnostic` parameter are listed in the description of each confirmed operation.

3.1.1.4 A `diagnostic` parameter value of ‘other reason’ shall be returned only if no other value in the list adequately describes the reason `result` is ‘negative result’.

3.1.2 PARAMETER TYPES

The types of all parameters shall conform to the abstract syntax specified in annex A.

NOTE – Some parameter types in annex A are chosen such that possible future extensions of the range of allowed values of a parameter will not cause a type mismatch. For example, parameters that logically are of the ‘enumerated’ type are specified as being of the ‘named integer’ type.

3.1.3 PARAMETER CHECKING

3.1.3.1 Validity checks shall be performed on the values of parameters associated with an operation.

NOTE – Rules governing the validity of parameter values are included in the specification of individual operations. General reasons for regarding a parameter value as invalid are specified in the following subsections.

3.1.3.2 A parameter shall be treated as invalid if:

- a) its value is outside the range or not in the set of values currently permitted by service management for the given parameter;

NOTE – A conformant implementation shall be capable of supporting the full range or set as specified in annex A.

- b) its value is in conflict with the value of another parameter in the same invocation (e.g., if in CLTU-TRANSFER-DATA the time specified in the `earliest-radiation-time` parameter is later than the time specified in the `latest-radiation-time` parameter);
- c) its value is in conflict with the current provider configuration (e.g., the minimum delay time between CLTUs parameter as set by service management is longer than the `delay-time` value the CLTU-TRANSFER-DATA invocation contains).

3.1.3.3 If a parameter value is not valid, the operation shall not be performed, and, for confirmed operations, a report with `result` set to ‘negative result’ shall be returned to the invoker.

3.1.3.4 Except as noted in 3.2.2.11, checks for invalid parameters or for other conditions that can cause `result` to be set to ‘negative result’ should be performed in the order in which the `diagnostic` values are listed in the descriptions of the operations, and the `diagnostic` parameter should be set to the value defined for the first problem found.

3.1.3.5 In the case that an implementation does not adhere to the sequence of checks as specified by the sequence of `diagnostic` values, such implementation shall specify the sequence in which the checks are actually performed.

3.1.4 ACCESS CONTROL

3.1.4.1 The FCLTU service shall implement access control based on the identity of the initiator and responder. Access control is performed at two levels:

- a) the initiator must be registered at the responder and the responder must be registered at the initiator;
- b) the initiator and responder must be authorized for the given service instance.

3.1.4.2 The initiator shall have access to a registry of authorized responders and the responder shall have access to a registry of authorized initiators. These registries shall be maintained by SLE Complex Management and SLE Utilization Management, respectively.

3.1.4.3 Service management shall specify the authorized initiator and responder for each service instance.

3.1.4.4 The initiator and responder shall indicate their identity by setting the parameters `initiator-identifier` and `responder-identifier` in the CLTU-BIND operation to the values assigned by service management.

3.1.5 AUTHENTICATION

NOTE – Requirements for security depend on the application and the environment of the SLE Complexes and the MDOS (e.g., whether closed or public networks are used or if access is only from physically restricted areas). In many environments, security may be provided by the communications service, transparently to the SLE application. This Recommended Standard does not preclude the use of security features that are provided by the communications service or the local environment, nor does it assume the availability of such features.

3.1.5.1 The FCLTU service shall provide the following options with respect to level of authentication of invocations and returns of operations:

- a) ‘all’: all FCLTU service invocations and returns, except the invocation of CLTU-PEER-ABORT, shall be authenticated;
- b) ‘bind’: only the CLTU-BIND invocation and return shall be authenticated;
- c) ‘none’: no FCLTU service invocations or returns shall be authenticated.

3.1.5.2 The FCLTU service provider should specify ‘all’ or ‘bind’ as the level of authentication required

3.1.5.3 SLE Complex Management and SLE Utilization Management shall agree on the level of authentication to be required for an association between an FCLTU service user and provider and shall configure both entities accordingly.

3.1.5.4 SLE Complex Management and SLE Utilization Management shall agree on the algorithm used to generate and check credentials parameters and make this algorithm known to the service user and service provider, together with associated parameters such as passwords or keys as necessary for the adopted algorithm.

NOTES

- 1 The specification of the algorithms themselves is outside the scope of this Recommended Standard. One possible specification of the authentication mechanism can be found in reference [G5].
- 2 The `initiator-identifier` and `responder-identifier` parameters of the CLTU-BIND operation identify the user and provider, respectively, and therefore the applicable authentication level and algorithm necessary to generate and check credentials.

3.1.5.5 For operations for which authentication of credentials is required by terms of the agreement between SLE Complex Management and SLE Utilization Management:

- a) invocations shall include an `invoker-credentials` parameter to permit the performer to authenticate the invocation; and
- b) returns shall include a `performer-credentials` parameter to permit the invoker to authenticate the return.

3.1.5.6 For operations for which authentication is not required, the `invoker-credentials` or `performer-credentials` parameter should be set to the value 'unused' to signify that the invocation or return does not carry credentials.

3.1.6 BLOCKING AND NON-BLOCKING OPERATIONS

3.1.6.1 To support applications that may need to invoke several operations concurrently, the `invoke-ID` parameter is specified for all confirmed operations except CLTU-BIND and CLTU-UNBIND.

NOTES

- 1 The `invoke-ID` parameter allows the invoker to correlate a particular return to the invocation that prompted it.
- 2 Confirmed operations that include the `invoke-ID` parameter are non-blocking operations; those that do not are blocking operations. Unconfirmed operations are always non-blocking.

3.1.6.2 After invoking a blocking operation, the invoker shall not invoke another operation for the same service instance until the return from the blocking operation is received; except that, if the return from a blocking operation is not received in a timely manner, the invoker may invoke CLTU-PEER-ABORT to terminate the association.

3.1.6.3 After invoking a non-blocking operation, the invoker may invoke another operation without waiting for the return from the first invocation.

3.1.6.4 The value of the `invoke-ID` parameter shall be an invoker-supplied arbitrary integer value that shall be returned, unchanged, by the performer.

3.1.6.5 The invocation of a non-blocking operation shall be rejected with the diagnostic 'duplicate invoke id' if it includes an `invoke-ID` whose value is the same as that of another invocation that is awaiting confirmation within the context of the same service instance.

3.1.6.6 To ensure that the FCLTU service behaves in a predictable manner, the effects of operations shall be as though the operations were performed in the order that their invocations were received by the performer.

3.1.6.7 The invoker may choose not to exploit the non-blocking capability and always wait for the return from a non-blocking operation before invoking another operation.

NOTE – An invoker wishing to operate in blocking mode, i.e., to invoke a new operation only after the return from the previous operation has been received, may use a constant value for the `invoke-ID` parameter. As long as a return is still outstanding, the performer will reject any further invocations.

3.1.6.8 Compliance with this Recommended Standard does not require the performer to process invocations concurrently; however, the performer must accept invocations from a non-blocking invoker and buffer and serialize them by local means not visible externally.

3.1.7 TIME

3.1.7.1 The time reference for all parameters containing a time value shall be based on Coordinated Universal Time (UTC).

3.1.7.2 The type of parameters containing a time value shall be the CCSDS Day Segmented (CDS) time code format (reference [5]) with an epoch of 1958-01-01 and a 16-bit day segment. Depending on the FCLTU service provider capabilities and/or the supported mission requirements, the time tag may have either a resolution of microseconds or a resolution of picoseconds.

3.1.7.3 All time values shall be expressed to a precision of at least one-tenth (0.1) of a second.

3.1.7.4 All time values shall be accurate to within one-tenth (0.1) of a second or better.

3.1.8 DELIVERY MODES

3.1.8.1 Forward Online Delivery

3.1.8.1.1 Forward online delivery service provision shall occur at the same time as service production, i.e., during a space link session.

3.1.8.1.2 CLTUs supplied by the service user shall be buffered by the service provider until they are processed.

3.1.8.1.3 The buffer used by the service provider exists only during service provisioning.

3.1.8.1.4 The timing of CLTU processing shall be determined by the order of CLTUs in the buffer and any annotation data provided with the CLTUs.

NOTE – The forward online delivery mode is defined in this Recommended Standard.

3.1.8.2 Forward Offline Delivery

The forward offline delivery mode is outside the scope of this version of this Recommended Standard.

3.1.9 SETTING OF PARAMETERS

3.1.9.1 An FCLTU service provider shall permit setting of the service configuration parameters as specified in table 3-1.

3.1.9.2 The range or set of values a parameter may assume is constrained by specification of its data type (see annex A).

3.1.9.3 Service management may further constrain the allowed values for a given service instance.

Table 3-1: Setting of FCLTU Service Configuration Parameters

Parameter	Service Management	CLTU-START Operation	CLTU-SCHEDULE-STATUS-REPORT Operation	CLTU-THROW-EVENT Operation (NOTE 3)
acquisition-sequence-length	X			
bit-lock-required	X			
clcw-physical-channel	X			
clcw-global-VCID	X			
delivery-mode	X			
expected-cltu-identification		X		
expected-event-invocation-identification				X
maximum-cltu-length	X			
minimum-delay-time	X			
minimum-reporting-cycle	X			
modulation-frequency	X			
modulation-index	X			
notification-mode	X			
plop-1-idle-sequence-length	X			
plop-in-effect	X			
protocol-abort-mode	X			

RECOMMENDED STANDARD FOR SLE FCLTU SERVICE

Parameter	Service Management	CLTU-START Operation	CLTU-SCHEDULE-STATUS-REPORT Operation	CLTU-THROW-EVENT Operation (NOTE 3)
reporting-cycle			X	
return-timeout-period	X			
rf-available-required	X			
service-instance-provision-period	X			
service-version-number	X			
subcarrier-to-bit-rate-ratio	X			

NOTES

- 1 Further details on protocol-abort-mode are discussed in 4.1.5. The notification-mode parameter is described in 3.7.2.3. Other parameters are presented and described in table 3-11. A complete list of parameters that may affect service production is to be found in the service management suite of documents (see 1.5.2).
- 2 The user can ascertain the current value of the parameters presented in table 3-11 by means of the CLTU-GET-PARAMETER operation.
- 3 The ability to modify selected service configuration parameters using the CLTU-THROW-EVENT operation is allowed but not mandated in this Recommended Standard.

3.1.10 PROVIDER BUFFERING REQUIREMENTS

3.1.10.1 The service package shall specify the amount of buffering the provider must maintain.

3.1.10.2 The amount of buffer space shall be specified in terms of the number of octets that can be stored.

3.1.10.3 The service provider shall buffer only complete CLTUs.

3.1.11 ACCOUNTING SUMMARY

Statistical information to be collected over a period of time shall always refer to the service instance provision period.

3.2 CLTU-BIND

3.2.1 PURPOSE

3.2.1.1 The initiator shall invoke the CLTU-BIND operation to establish an association between the initiator and responder as defined in 1.6.1.6.1.

3.2.1.2 The responder shall return a report of the outcome of the performance of the CLTU-BIND operation to the initiator.

3.2.1.3 Except as provided in 3.2.1.4, the initiator shall not invoke any further FCLTU service operations for this service instance until the return from the responder is received.

3.2.1.4 If the return from the invocation of CLTU-BIND is not received after a sufficiently long time, the initiator may attempt to recover by invoking the CLTU-PEER-ABORT operation (see 3.12) followed by another CLTU-BIND.

NOTE – The length of the duration that constitutes ‘a sufficiently long time’ is determined by service management.

3.2.1.5 The CLTU-BIND operation is valid only in state 1 (‘unbound’) and shall be invoked only by the user.

3.2.2 INVOCATION, RETURN, AND PARAMETERS

3.2.2.1 General

The parameters of the CLTU-BIND operation shall be present in the invocation and return as specified in table 3-2.

3.2.2.2 `invoker-credentials`

The `invoker-credentials` parameter shall provide information that enables the performer to authenticate the CLTU-BIND invocation (see 3.1.5).

3.2.2.3 `performer-credentials`

The `performer-credentials` parameter shall provide information that enables the invoker to authenticate the return from the performance of CLTU-BIND (see 3.1.5).

Table 3-2: CLTU-BIND Parameters

Parameter	Invocation	Return
invoker-credentials	M	
performer-credentials		M
initiator-identifier	M	
responder-identifier		M
responder-port-identifier	M	
service-type	M	
version-number	M	C
service-instance-identifier	M	
result		M
diagnostic		C

3.2.2.4 initiator-identifier

The **initiator-identifier** parameter shall identify the authority on whose behalf the SLE application entity is initiating an association.

NOTES

- 1 The `initiator-identifier` parameter permits the responder to determine if the initiator is registered at this responder and if the CLTU-BIND operation is being invoked by the authorized initiator for this service instance.
- 2 Each value of the `initiator-identifier` parameter is associated with exactly one authentication level and exactly one authentication scheme.
- 3 If authentication based on credentials is used, this parameter may be redundant since the `initiator-identifier` value may be one constituent of the `invoker-credentials` parameter. However, the encoding may differ, and it may be convenient to have this parameter also available in 'clear text' form.

3.2.2.5 responder-identifier

The **responder-identifier** parameter shall identify the authority on whose behalf the responding SLE application is acting.

NOTES

- 1 The `responder-identifier` parameter permits the initiator to determine if the responder from which the CLTU-BIND return originates is registered at this initiator.

- 2 The initiator uses this parameter, if applicable, after having successfully authenticated the CLTU-BIND return to determine if this return originates from the intended responder.

3.2.2.6 responder-port-identifier

NOTE – The `responder-port-identifier` parameter is included in the CLTU-BIND invocation to support its possible use by particular kinds of gateways. It is used by such gateways to complete the association with the responding SLE application entity, and it is not intended to be used by the responding SLE application entity itself. Implementations not requiring this parameter can ignore its value. Beyond this statement, the behavior of such gateways is outside the scope of this Recommended Standard.

3.2.2.6.1 The `responder-port-identifier` parameter shall contain the port identifier of the responding SLE application entity with which the initiator seeks to establish an association.

3.2.2.6.2 The responding SLE application entity shall ignore the value of the `responder-port-identifier` parameter for purposes of determining the validity of the invocation.

NOTES

- 1 The value of the `responder-port-identifier` parameter is a logical name that can be translated into the technology-specific addressing information required to establish a connection with the responder using the agreed upon communications service. See 2.6.4.5 for more information.
- 2 SLE Complex Management and SLE Utilization Management must have previously agreed on the `responder-port-identifier` and its translation that is applicable to a particular instance of service.
- 3 In case the `responder-port-identifier` parameter is required to establish the association between user and provider, but its value is incorrectly set, the CLTU-BIND invocation will in general fail without return. This will trigger the ‘return timeout’ event on the invoker side. As specified in 4.1.3, the invoker will abort the association by invoking the CLTU-PEER-ABORT operation with the `diagnostic` parameter set to ‘return timeout’.

3.2.2.7 `service-type`

The `service-type` parameter shall specify the type of service that will be provided if the CLTU-BIND operation succeeds.¹

3.2.2.8 `version-number`

3.2.2.8.1 The `version-number` parameter shall identify the version number of the FCLTU service specification that is to govern this association if the CLTU-BIND succeeds.

3.2.2.8.2 `version-number` is conditionally present in the return based on the value of the `result` parameter:

- a) if `result` is 'positive result', `version-number` shall be present in the return;
- b) if `result` is 'negative result', `version-number` shall not be present in the return.

3.2.2.8.3 If a provider does not support version negotiation, the `version-number` value it will accept during the BIND operation is configured by means of the managed parameter `service-version-number` (see table 3-1).

3.2.2.8.4 If `result` is 'positive result', the responder shall either:

- a) accept the version proposed by the initiator by putting the same version number into the positive return; or
- b) if the responder supports version negotiation, propose a lower (earlier) version number by putting the lower version number in the return.

3.2.2.8.5 If the responder implementation does not support the requested version and does not support a lower version (or does not support version negotiation), the responder shall reject the CLTU-BIND invocation with the `diagnostic` parameter set to 'version not supported'.

3.2.2.8.6 If the responder proposes a lower version in the return and the initiator does not support version negotiation or does not support the version proposed by the responder, the initiator shall unbind the association.

¹ For the CLTU-BIND operation, the `service-type` parameter is redundant, because the only valid value of `service-type` is 'fwdCltu'. However, it is anticipated that future work by CCSDS will result in CLTU-BIND being superseded by a generic SLE-BIND operation that is invoked with any one of several SLE service types as specified by `ApplicationIdentifier` in annex A. The CLTU-BIND `service-type` parameter is provided in an attempt to facilitate such a change.

3.2.2.8.7 The `version-number` value of the FCLTU service defined by this issue of this Recommended Standard shall be '6'.

NOTE – The version negotiation process as outlined above is only feasible as long as future versions of the FCLTU service retain the specification of the CLTU-BIND operation.

3.2.2.9 service-instance-identifier

The **service-instance-identifier** parameter shall uniquely identify this service instance within the scope of the service-providing SLE Complex.

3.2.2.10 result

3.2.2.10.1 The **result** parameter shall specify the result of the CLTU-BIND invocation and shall contain one of the following values:

- a) 'positive result'—the CLTU-BIND operation has been performed by the responder and the association is established;
- b) 'negative result'—the CLTU-BIND operation has not been performed by the responder for the reason specified in the `diagnostic` parameter, and the association is not established.

3.2.2.11 diagnostic

3.2.2.11.1 If `result` is 'negative result', **diagnostic** shall be present and its value shall be one of the following values:

- a) 'access denied'—an initiator with the `initiator-identifier` value presented in the CLTU-BIND invocation is not registered at the responder;
- b) 'service type not supported'—the value of the `service-type` parameter of the CLTU-BIND invocation does not identify a service type supported by the responder;
- c) 'version not supported'—the responder does not support the requested version and the responder implementation does not permit version negotiation; or the responder does not support any version of the service lower than the one requested by the initiator;
- d) 'no such service instance'—the requested service instance is not defined by any agreed upon service package known to the responder;
- e) 'already bound'—the service instance is already bound via a different association;

RECOMMENDED STANDARD FOR SLE FCLTU SERVICE

- f) ‘service instance not accessible to this initiator’—the initiator identified by the `initiator-identifier` parameter of the CLTU-BIND invocation does not match the authorized initiator for the service instance identified by the `service-instance-identifier` parameter;
- g) ‘inconsistent service type’—the value of the `service-type` parameter of the CLTU-BIND invocation is not ‘`fwdCltu`’, or the value of the `service-type` parameter does not match the service type of the service instance identified by the `service-instance-identifier` parameter;
- h) ‘invalid time’—the CLTU-BIND operation was invoked outside the service instance provision period of the service instance identified by the `service-instance-identifier` parameter;
- i) ‘out of service’—the responder has been taken out of service for an indefinite period by management action, i.e., `production-status` is ‘halted’;
- j) ‘other reason’—the reason for the negative result will have to be found by other means.

NOTES

- 1 In some implementations, under some circumstances, it may not be possible for the intended performer to provide a return in the event of the conditions indicated by diagnostic d), h) or i).
- 2 Initiators should consider that, under some conditions, CLTU-BIND may fail with no return, e.g., if the value of the `responder-port-identifier` parameter is incorrect.

3.2.2.11.2 If `result` is ‘positive result’, `diagnostic` shall not be present in the return.

3.2.3 EFFECTS

3.2.3.1 If `result` is ‘positive result’, the CLTU-BIND operation shall have the following effects:

- a) an association between the user and the provider shall be established;
- b) the provider shall transition from state 1 (‘unbound’) to state 2 (‘ready’);
- c) upon receipt of a positive return, the user may proceed to invoke other FCLTU service operations, e.g., to enable the transfer of CLTUs.

3.2.3.2 If `result` is ‘negative result’, the CLTU-BIND operation shall have the following effects:

- a) the association between the user and the provider shall not be established;

RECOMMENDED STANDARD FOR SLE FCLTU SERVICE

- b) the provider state shall remain unchanged;
- c) upon receipt of the negative return:
 - 1) the initiator should examine the `diagnostic` parameter for the cause;
 - 2) the initiator may attempt to re-invoke the CLTU-BIND.

3.3 CLTU-UNBIND

3.3.1 PURPOSE

3.3.1.1 The initiator shall invoke the CLTU-UNBIND to release an association previously established by CLTU-BIND (see 3.2).

3.3.1.2 The responder shall return a report of the outcome of the performance of the CLTU-UNBIND operation to the initiator.

3.3.1.3 Except as provided in 3.3.1.4, the initiator shall not invoke any further FCLTU service operations for this service instance until the return from CLTU-UNBIND is received; nor shall it perform any further operations invoked by the responder; nor shall it return to the responder any further reports of the outcome of operations invoked by the responder.

NOTE – The initiator may invoke the CLTU-UNBIND operation even if it did not yet receive all returns from previously invoked operations. The initiator should be aware that the responder may choose not to send any further returns as soon as it has received the CLTU-UNBIND invocation. It may then happen that the CLTU-UNBIND return is not received before one of the missing returns causes a missing return timeout (see 4.1.3).

3.3.1.4 If the return from the CLTU-UNBIND invocation is not received after a sufficiently long time, the initiator should invoke the CLTU-PEER-ABORT operation (see 3.12) to abort the association.

NOTES

- 1 The length of the duration that constitutes ‘a sufficiently long time’ is determined by service management.
- 2 Following receipt of the return from CLTU-UNBIND or following the invocation of CLTU-PEER-ABORT, the initiator may issue another CLTU-BIND if otherwise permitted (e.g., if the end of the service instance provision period has not been reached).

3.3.1.5 The CLTU-UNBIND operation is valid only in state 2 (‘ready’)

3.3.1.6 The CLTU-UNBIND operation shall be invoked only by the initiator (i.e., the invoker of the CLTU-BIND operation that established this association).

3.3.2 INVOCATION, RETURN, AND PARAMETERS

3.3.2.1 General

The parameters of the CLTU-UNBIND operation shall be present in the invocation and return as specified in table 3-3.

Table 3-3: CLTU-UNBIND Parameters

Parameter	Invocation	Return
invoker-credentials	M	
performer-credentials		M
unbind-reason	M	
result		M

3.3.2.2 invoker-credentials

The **invoker-credentials** parameter shall provide information that enables the performer to authenticate the CLTU-UNBIND invocation (see 3.1.5).

3.3.2.3 performer-credentials

The **performer-credentials** parameter shall provide information that enables the invoker to authenticate the return from the performance of CLTU-UNBIND (see 3.1.5).

3.3.2.4 unbind-reason

The **unbind-reason** parameter shall indicate the reason for which the CLTU-UNBIND operation is being invoked and shall contain one of the following values:

- a) 'end'—the initiator has completed the transfer of its data and is releasing the association normally: the provider may delete the service instance and release all its resources associated with it;

NOTE – If unbind-reason is 'end', any subsequent attempt to invoke CLTU-BIND may fail even if the service instance provision period has not expired, since the service provider may release the resources allocated to that service instance. In particular, the service instance may be removed and therefore be no longer accessible.

- b) 'suspend'—the initiator is suspending usage of this service instance for an unspecified period of time; the user may or may not re-bind to the provider to continue data transfer at some time prior to the end of the service instance provision period;
- c) 'version not supported'—the initiator does not support the version of the FCLTU service proposed by the provider in the return from CLTU-BIND: this value of unbind-reason shall be used only if the CLTU-UNBIND is the first operation invoked following the CLTU-BIND;
- d) 'other reason'—the reason for the release will have to be found by other means.

3.3.2.5 result

The **result** parameter shall specify the result of the CLTU-UNBIND invocation and shall always contain the following value:

‘positive result’—the CLTU-UNBIND invocation is accepted by the responder and the association is released.

NOTES

- 1 If CLTU-UNBIND is invoked while the provider is not in the ‘ready’ state, the responder invokes CLTU-PEER-ABORT; if the authentication level is ‘all’ and the invocation of CLTU-UNBIND cannot be authenticated, the responder ignores it; there is no situation in which the response to the invocation of CLTU-UNBIND is to return the `result` parameter set to the value ‘negative result’.
- 2 The `result` parameter is returned for the CLTU-UNBIND operation, even though the only permitted value is ‘positive result’, for consistency with other confirmed operations.
- 3 CLTU-UNBIND is a confirmed operation in order to provide a definite indication to the initiator that the responder has performed the operation and the association is released.

3.3.3 EFFECTS

3.3.3.1 The CLTU-UNBIND operation shall have the following effects:

- a) the association between the initiator and the responder shall be released, and the initiator and the responder shall cease to communicate with each other;
- b) the provider shall transition to state 1 (‘unbound’);
- c) If `unbind-reason` is ‘end’, the provider may terminate the service instance and release its resources;
- d) If `unbind-reason` is not ‘end’, the initiator may attempt to re-bind at any time prior to the end of the service instance provision period.

3.4 CLTU-START

3.4.1 PURPOSE

3.4.1.1 The user shall invoke the CLTU-START operation to request that the FCLTU service provider prepare to receive CLTU-TRANSFER-DATA invocations (see 3.6).

3.4.1.2 The FCLTU service provider shall return a report of the outcome of the performance of the CLTU-START operation to the user.

3.4.1.3 The CLTU-START operation shall allow the FCLTU service provider to return to the user the times scheduled for start and stop of production.

3.4.1.4 CLTU-START is valid only in state 2 ('ready') and shall be invoked only by the user.

3.4.2 INVOCATION, RETURN AND PARAMETERS

3.4.2.1 General

The parameters of the CLTU-START operation shall be present in the invocation and return as specified in table 3-4.

Table 3-4: CLTU-START Parameters

Parameters	Invocation	Return
invoker-credentials	M	
performer-credentials		M
invoke-ID	M	M
first-cltu-identification	M	
start-production-time		C
stop-production-time		C
result		M
diagnostic		C

3.4.2.2 invoker-credentials

The **invoker-credentials** parameter shall provide information that enables the performer to authenticate the CLTU-START invocation (see 3.1.5).

3.4.2.3 **performer-credentials**

The **performer-credentials** parameter shall contain information that enables the invoker to authenticate the return from the performance of CLTU-START (see 3.1.5).

3.4.2.4 **invoke-ID**

The FCLTU service provider shall return unchanged the user-supplied value of the **invoke-ID** parameter (see 3.1.6).

3.4.2.5 **first-cltu-identification**

The **first-cltu-identification** parameter value shall specify the `cltu-identification` value that the FCLTU service provider shall expect to receive in the first CLTU-TRANSFER-DATA operation after the CLTU-START.

NOTE – Following certain exceptions (e.g. ‘sldu expired’, see 3.7.2.3), it is necessary to invoke CLTU-STOP followed by CLTU-START. A CLTU that was being processed when CLTU-STOP was invoked may still cause a notification to be invoked after the new CLTU-START invocation. Therefore the value of the `first-cltu-identification` parameter in the new CLTU-START invocation should be chosen such that a CLTU for which processing did not yet complete can be uniquely identified.

3.4.2.6 **start-production-time**

3.4.2.6.1 If the `production-status` is not yet ‘operational’, **start-production-time** shall be the estimated time at which the FCLTU service provider will be able to start radiating CLTUs; it shall be determined from the schedule, with allowance for completion of the uplink acquisition sequence.

3.4.2.6.2 If `production-status` is ‘operational’ and the provider is ready to start radiating CLTUs, `start-production-time` shall contain the time when `production-status` changed to ‘operational’.

3.4.2.6.3 If there is a subsequent CLTU-START operation within a service instance, the `start-production-time` parameter shall contain the latest time the provider became ready to radiate; i.e., the most recent time when `production-status` changed to ‘operational’.

3.4.2.6.4 The `start-production-time` parameter shall be returned only if result is ‘positive result’.

3.4.2.7 stop-production-time

3.4.2.7.1 stop-production-time shall be the estimated time at which the provider will stop radiating CLTUs.

NOTE – The value of the `stop-production-time` parameter may be a time later than the end of the service instance provision period.

3.4.2.7.2 If the estimated stop time is not available to the provider, the `stop-production-time` parameter shall contain a value of 'null'.

3.4.2.7.3 The `stop-production-time` parameter shall be returned only if `result` is 'positive result'.

3.4.2.8 result

The **result** parameter shall specify the result of the CLTU-START operation and shall contain one of the following values:

- a) 'positive result'—the CLTU-START operation has been performed by the provider and the initiator may start invoking CLTU-TRANSFER-DATA operations;
- b) 'negative result'—the CLTU-START operation has not been performed by the provider for the reason specified in the `diagnostic` parameter; the provider cannot accept CLTU-TRANSFER-DATA invocations.

3.4.2.9 diagnostic

3.4.2.9.1 If `result` is 'negative result', **diagnostic** shall be present in the return, and its value shall be one of the following:

- a) 'duplicate invoke-ID'—the value of the `invoke-ID` parameter is the same as the `invoke-ID` value of a previous, outstanding operation;
- b) 'out of service'—the provider has been taken out of service for an indefinite period by management action; i.e., `production-status` is 'halted';
- c) 'unable to comply'—the provider is unable to accept data at this time because of a possibly temporary fault condition affecting the provider; i.e., `production-status` is 'interrupted';
- d) 'production time expired'—the time period scheduled for production of CLTUs is already past;
- e) 'invalid cltu-ID'—the `first-cltu-identification` parameter value is less than the `cltu-identification` parameter value of a CLTU already in the buffer;

- f) ‘other reason’—the reason for the negative result will have to be found by other means.

3.4.2.9.2 If `result` is ‘positive result’, `diagnostic` shall not be present in the return.

3.4.3 EFFECTS

3.4.3.1 If `result` is ‘positive result’, the CLTU-START operation shall have the following effects:

- a) the provider shall transition to state 3 (‘active’);
- b) in the ‘active’ state, the provider shall accept CLTU-TRANSFER-DATA invocations.

3.4.3.2 If `result` is ‘negative result’, the CLTU-START operation shall have the following effects:

- a) the provider state shall remain unchanged;
- b) if `diagnostic` is ‘unable to comply’:
 - 1) the user may re-invoke the CLTU-START operation at a later time, within the constraints of the service instance provision period;
 - 2) if the provider’s complex management determines that being ‘unable to comply’ is more than a transient problem, the provider may invoke the CLTU-PEER-ABORT operation.

3.5 CLTU-STOP

3.5.1 PURPOSE

3.5.1.1 The user shall invoke the CLTU-STOP operation to request that the provider stop production, i.e., stop radiation, of CLTUs already received but not yet radiated.

NOTE – Within the constraints of the service instance provision period, the user may re-enable the reception and production of CLTUs on the provider side by invoking the CLTU-START operation.

3.5.1.2 The provider shall provide a report of the outcome of the performance of the CLTU-STOP operation to the user.

3.5.1.3 The CLTU-STOP operation is valid only in state 3 ('active') and shall be invoked only by the user.

3.5.2 INVOCATION, RETURN AND PARAMETERS

3.5.2.1 General

The parameters of the CLTU-STOP operation shall be present in the invocation and return as specified in table 3-5.

Table 3-5: CLTU-STOP Parameters

Parameters	Invocation	Return
invoker-credentials	M	
performer-credentials		M
invoke-ID	M	M
result		M
diagnostic		C

3.5.2.2 invoker-credentials

The **invoker-credentials** parameter shall provide information that enables the performer to authenticate the CLTU-STOP invocation (see 3.1.5).

3.5.2.3 performer-credentials

The **performer-credentials** parameter shall provide information that enables the invoker to authenticate the return from the performance of CLTU-STOP (see 3.1.5).

3.5.2.4 **invoke-ID**

The FCLTU service provider shall return unchanged the user-supplied value of the **invoke-ID** parameter (see 3.1.6).

3.5.2.5 **result**

The **result** parameter shall specify the result of the CLTU-STOP operation and shall contain one of the following values:

- a) ‘positive result’—the CLTU-STOP operation has been performed by the provider and the user may invoke a CLTU-UNBIND operation or a new CLTU-START operation;
- b) ‘negative result’—the CLTU-STOP operation has not been performed by the provider for the reason specified by the **diagnostic** parameter.

3.5.2.6 **diagnostic**

3.5.2.6.1 If **result** is ‘negative result’, **diagnostic** shall be present in the return and its value shall contain one of the following:

- a) ‘duplicate invoke-ID’—the value of the **invoke-ID** parameter is the same as the **invoke-ID** value of a previous, outstanding operation;
- b) ‘other reason’—the reason for the negative result will have to be found by other means.

3.5.2.6.2 If **result** is ‘positive result’, **diagnostic** shall not be present in the return.

3.5.3 EFFECTS

3.5.3.1 If **result** is ‘positive result’, the CLTU-STOP operation shall have the following effects:

- a) the provider shall transition to state 2 (‘ready’) and shall no longer accept CLTU-TRANSFER-DATA invocations;
- b) for CLTUs already buffered:
 - 1) the provider shall discard any CLTUs for which radiation has not yet begun;
 - 2) the provider shall not discard, but shall complete radiation of, a CLTU in the process of being radiated;

NOTE – An additional CLTU could be radiated after the provider receives the CLTU-STOP invocation, depending on implementation specifics.

RECOMMENDED STANDARD FOR SLE FCLTU SERVICE

- c) if a report has been requested by the user for a CLTU that is already being radiated, the report shall be generated upon completion of processing of that CLTU and sent to the user by means of a CLTU-ASYNC-NOTIFY operation.

3.5.3.2 If `result` is 'negative result':

- a) processing shall continue;
- b) any buffered CLTUs shall not be discarded;
- c) the provider state shall remain unchanged.

3.6 CLTU-TRANSFER-DATA

3.6.1 PURPOSE

3.6.1.1 The user shall invoke the CLTU-TRANSFER-DATA operation to transfer CLTUs to the provider.

3.6.1.2 The provider shall provide a report of the outcome of the performance of the CLTU-TRANSFER-DATA operation to the user.

3.6.1.3 The CLTU-TRANSFER-DATA operation is valid only in state 3 ('active') and shall be invoked only by the user.

3.6.2 INVOCATION, RETURN, AND PARAMETERS

3.6.2.1 General

The parameters of the CLTU-TRANSFER-DATA operation shall be present in the invocation and return as specified in table 3-6.

Table 3-6: CLTU-TRANSFER-DATA Parameters

Parameters	Invocation	Return
invoker-credentials	M	
performer-credentials		M
invoke-ID	M	M
cltu-identification	M	M
earliest-radiation-time	M	
latest-radiation-time	M	
delay-time	M	
report	M	
data	M	
cltu-buffer-available		M
result		M
diagnostic		C

3.6.2.2 invoker-credentials

The **invoker-credentials** parameter shall provide information that enables the performer to authenticate the CLTU-TRANSFER-DATA invocation (see 3.1.5).

3.6.2.3 performer-credentials

The **performer-credentials** parameter shall provide information that enables the invoker to authenticate the return from the performance of CLTU-TRANSFER-DATA (see 3.1.5).

3.6.2.4 invoke-ID

The FCLTU service provider shall return unchanged the user-supplied value of the **invoke-ID** parameter (see 3.1.6).

3.6.2.5 cltu-identification

3.6.2.5.1 The **cltu-identification** parameter shall contain a monotonically increasing sequence number and shall be:

- a) set for the first CLTU-TRANSFER-DATA invocation after a successful CLTU-START invocation to the value of the **first-cltu-identification** parameter of that CLTU-START invocation;
- b) incremented for each CLTU-TRANSFER-DATA invocation accepted by the provider.

3.6.2.5.2 The provider shall set the value of the **cltu-identification** parameter to the sequence number expected in the next CLTU-TRANSFER-DATA invocation:

- a) if the invocation is accepted, the **cltu-identification** in the return shall be one greater than the value in the invocation;
- b) if the invocation is rejected, the **cltu-identification** in the return shall contain the value expected by the FCLTU service provider:
 - 1) in the case of the first CLTU-TRANSFER-DATA operation following a CLTU-START, it is the value specified in the **first-cltu-identification** parameter of the CLTU-START operation;
 - 2) otherwise, the value is one greater than the value of the **cltu-identification** parameter of the last accepted CLTU-TRANSFER-DATA operation.

NOTE – It is assumed that the supported range of this parameter is sufficiently large that no two CLTUs within the CLTU buffer will have the same **cltu-identification** value.

3.6.2.6 **earliest-radiation-time**

3.6.2.6.1 The `earliest-radiation-time` parameter shall either be unspecified, i.e., contain a value of 'null', or shall specify the earliest time at which the leading edge of the first bit of the CLTU may begin to be radiated.

3.6.2.6.2 If the `earliest-radiation-time` parameter is unspecified, the provider shall begin processing immediately after any delay specified by the `delay-time` parameter associated with the previous CLTU has timed out, as long as `production-status` is 'operational'.

3.6.2.7 **latest-radiation-time**

3.6.2.7.1 The `latest-radiation-time` parameter shall either be unspecified (i.e. contain a value of 'null'), or shall specify the latest time at which the leading edge of the first bit of the CLTU may begin to be radiated.

3.6.2.7.2 If the `latest-radiation-time` parameter is unspecified, the provider shall process the CLTU as long as the service instance is in state 3 ('active') and `production-status` is not 'halted'.

3.6.2.7.3 If `latest-radiation-time` is specified, i.e., it is not 'null', the provider shall defer processing of a CLTU if the current `production-status` value is 'interrupted'. Processing shall be deferred until either recovery from a temporary problem is accomplished, i.e., the `production-status` value changes to 'operational' before `latest-radiation-time` expires, or `latest-radiation-time` expires, in which case the provider shall discard the CLTU.

3.6.2.7.4 If `latest-radiation-time` equals `earliest-radiation-time`, radiation shall occur at this time.

3.6.2.7.5 If radiation has not begun at or before `latest-radiation-time`, an 'sldu expired' exception shall be notified to the user, and the CLTU shall not be radiated.

3.6.2.8 **delay-time**

3.6.2.8.1 The `delay-time` parameter shall contain the minimum radiation delay, in microseconds, between the CLTU transferred in this operation and the next CLTU.

3.6.2.8.2 The effect of `delay-time` depends on the setting of the `plop-in-effect` parameter. The behavior of each of the PLOPs is determined not only by the value of the `delay-time` parameter, but by the values of managed parameters of the FCLTU service. The following subsections specify the behavior of the PLOPs as they are affected by the `delay-time` parameter and the relevant managed parameters, in the context of the FCLTU service.

a) When the PLOP in effect is PLOP-1 (reference [2]):

- 1) Initially, the carrier shall be unmodulated (CMM-1 – see reference [2]) until a CLTU is received via a CLTU-TRANSFER-DATA invocation.

NOTE – Strictly speaking, CMM-1 only means that the carrier must not be modulated by CLTU radiation related signals. The carrier may however be modulated e.g. by a forward ranging signal. During the uplink sweep a clean, i.e., truly unmodulated carrier must be transmitted.

- 2) Upon receipt of a CLTU-TRANSFER-DATA invocation, an acquisition sequence of length `acquisition-sequence-length` (see table 3-1) shall be transmitted (CMM-2).

NOTE – The beginning of transmission of the acquisition sequence may be delayed to ensure that the CLTU does not begin radiation until that CLTU's `earliest-radiation-time`.

- 3) If the value of `plop-1-idle-sequence-length` (see table 3-1) is greater than zero ('0'), a leading idle sequence of length `plop-1-idle-sequence-length` shall be transmitted after the acquisition sequence (CMM-4).

NOTE – The `acquisition-sequence-length` and the `plop-1-idle-sequence-length` may both be set to zero ('0') and the actually required acquisition sequence (and optional leading and trailing idle sequences) may be inserted into the CLTU, as such enabling commanding of spacecraft that do not fully adhere to PLOP-1 as per reference [2].

- 4) Following transmission of the acquisition sequence and optional idle sequence, the CLTU shall be transmitted (CMM-3).

- 5) If the value of `plop-1-idle-sequence-length` (see table 3-1) is greater than zero ('0'), a trailing idle sequence of length `plop-1-idle-sequence-length` shall be transmitted following the transmission of the CLTU (CMM-4).

- 6) Following transmission of the CLTU or optional trailing idle sequence, the carrier shall cease being modulated by CLTU radiation related data and shall remain unmodulated (CMM-1) by such data until the latest of

- i. the expiration of `delay-time` specified for the most-recently-radiated CLTU, as measured from the trailing edge of the last radiated bit of the CLTU or optional trailing idle sequence,
- ii. availability for radiation of a subsequent CLTU, or

RECOMMENDED STANDARD FOR SLE FCLTU SERVICE

- iii. the end of the communications session (i.e. the end of production of the forward space link).
 - 7) When both (a) a subsequent CLTU is available for radiation and (b) the `delay-time` specified for the previous CLTU has expired, the subsequent CLTU shall be transmitted in accordance with steps 2) through 7). This process shall repeat until the end of the communications session.
- b) When the PLOP in effect is PLOP-2 (reference [2]):
- 1) Initially, the carrier is unmodulated (CMM-1) during the uplink sweep.
 - 2) Following the uplink sweep, an acquisition sequence of length `acquisition-sequence-length` (see table 3-1) is transmitted (CMM-2).
 - 3) Following the transmission of the acquisition sequence, an idle sequence shall be transmitted (CMM-4).

NOTE – For PLOP-2 the idle sequence has no fixed length.

- 4) When a CLTU becomes available for radiation, the CLTU shall be transmitted (CMM-3).
- 5) Following transmission of the CLTU, the idle sequence shall be transmitted (CMM-4) until the latest of
 - i. the expiration of `delay-time` specified for the most recently radiated CLTU, as measured from the trailing edge of the last radiated bit of the CLTU, or
 - ii. availability for radiation of a subsequent CLTU.
- 6) When both (a) a subsequent CLTU is available for radiation and (b) the `delay-time` specified for the previous CLTU has expired, the subsequent CLTU shall be transmitted in accordance with steps 4) through 6) until the end of the communications session (i.e., end of production of the forward space link).

NOTE – According to (reference [2]), PLOP-2 includes a final transition to unmodulated carrier (CMM-1) prior to the end of the communications session. However, there is no standard mechanism defined for determining when the transition from idle sequence modulation to no modulation is to occur.

3.6.2.9 report

The **report** parameter shall specify whether the provider shall invoke the CLTU-ASYNC-NOTIFY operation upon completion of the radiation of the CLTU, and shall contain one of the following values:

- a) ‘produce report’—invoke a CLTU-ASYNC-NOTIFY operation upon completion of the radiation of the CLTU;
- b) ‘do not produce report’—do not invoke the CLTU-ASYNC-NOTIFY operation.

3.6.2.10 data

The **data** parameter shall contain a CLTU for radiation to the space element of a mission.

NOTE – TC frames embedded in CLTUs may be protected by means of the Space Data Link Security Protocol [G6]. The presence or absence of such protection is transparent to the FCLTU service and creation of the Security Header and Security Trailer has to be performed by applications generating the CLTUs handled by the FCLTU service.

3.6.2.11 cltu-buffer-available

The **cltu-buffer-available** parameter shall specify the remaining number of octets available for buffering CLTUs.

NOTE – Real-world implementations in general will have a small additional buffer at the modulator input in order to prevent data underflow in particular at high command rates and when the interface towards the modulator is asynchronous, e.g., based on TCP. Users should be aware that such additional buffer is not reflected in the reported **cltu-buffer-available** parameter value, as such modulator buffer is part of service production and outside the service provisioning.

3.6.2.12 result

The **result** parameter shall specify the result of the CLTU-TRANSFER-DATA operation and shall contain one of the following values:

- a) ‘positive result’—the CLTU-TRANSFER-DATA operation has been performed by the provider and the data will be buffered until processing is due;
- b) ‘negative result’—the CLTU-TRANSFER-DATA operation has not been performed by the provider, for the reason returned in the diagnostic parameter.

3.6.2.13 diagnostic

3.6.2.13.1 If **result** is ‘negative result’, **diagnostic** shall be present in the return and its value shall be one of the following:

- a) ‘duplicate invoke-ID’ —the value of the **invoke-ID** parameter is the same as the **invoke-ID** value of a previous, outstanding operation;

RECOMMENDED STANDARD FOR SLE FCLTU SERVICE

- b) ‘unable to process’—the provider cannot process CLTUs for one of the following reasons:
- 1) the provider has been taken out of service for an indefinite period by management action, i.e., `production-status` is ‘halted’;
 - 2) `production-status` is ‘interrupted’, and the provider has reported the fault condition to the user via a CLTU-ASYNC-NOTIFY operation containing the `notification-type` value ‘production interrupted’;

NOTE – The provider may defer notifying the user when the `production-status` becomes ‘interrupted’, until a CLTU becomes ready to radiate. In this case, the provider continues to accept CLTU-TRANSFER-DATA operations so long as the notification has not been sent. See annex B.

- 3) `production-status` is ‘operational’ but the provider is blocked because of an earlier fault: the provider has reported the fault condition to the user by a CLTU-ASYNC-NOTIFY operation containing the `notification-type` value ‘production interrupted’ and has reported the recovery from the fault condition to the user by a CLTU-ASYNC-NOTIFY operation containing the `notification-type` value ‘production operational’;
 - 4) `production-status` is ‘operational’, but the provider is blocked due to an expired CLTU: the provider has reported the fault condition to the user via a CLTU-ASYNC-NOTIFY operation containing the `notification-type` value ‘sldu expired’;
 - 5) `production-status` is ‘operational’, but the provider has temporarily suspended production to process a CLTU-THROW-EVENT invocation: no fault condition has been reported to the user;
- c) ‘unable to store’—there is not enough buffer space available to store this CLTU;
- d) ‘out of sequence’—the value of the `cltu-identification` parameter is not equal to the value expected by the provider, which is one of the following:
- 1) in the case of the first CLTU-TRANSFER-DATA operation following a CLTU-START, the value specified by the user in the `first-cltu-identification` parameter of the CLTU-START operation;
 - 2) otherwise, the value of the `cltu-identification` parameter specified by the provider in the most recent positive CLTU-TRANSFER-DATA return;
- e) ‘inconsistent time range’—the time specified in the `earliest-radiation-time` parameter is later than the time specified in the `latest-radiation-time` parameter;
- f) ‘invalid time’—the radiation time window is invalid, for one of the following reasons:

RECOMMENDED STANDARD FOR SLE FCLTU SERVICE

- 1) the period from `earliest-radiation-time` to `latest-radiation-time` does not overlap with the range of times for which service production is scheduled;
- 2) the period from `earliest-radiation-time` to `latest-radiation-time` does not overlap with the service instance provision period;

NOTE – The production may be scheduled to terminate earlier than the service instance provision period ends. An SLE Complex may do so to have the production engine available for support of a different mission as soon as possible, but permitting the users of the previous production period some extra time to retrieve for example a status report reflecting the final accounting information.

- g) ‘late sldu’—`latest-radiation-time` is earlier than the time the `CLTU-TRANSFER-DATA` invocation is received by the provider;
- h) ‘invalid delay time’—the value of the `delay-time` parameter is less than the `minimum-delay-time` value set by Service Management;
- i) ‘CLTU error’—the provider has performed error checks as provided in the service agreement and has determined that this CLTU is in error; for example the CLTU exceeds the maximum size allowed for this service instance;
- j) ‘other reason’—the reason for the negative result will have to be found by other means.

3.6.2.13.2 If `result` is ‘positive result’, `diagnostic` shall not be present in the return.

3.6.3 EFFECTS

3.6.3.1 If `result` is ‘positive result’, the `CLTU-TRANSFER-DATA` operation shall have the following effects:

- a) the provider shall buffer the CLTU until it is due to be processed;
- b) the provider shall process CLTUs in the sequence received and according to the radiation time and delay parameters.

3.6.3.2 If `result` is ‘negative result’, the CLTU contained in the `CLTU-TRANSFER-DATA` invocation shall not be buffered.

3.6.3.3 The provider state shall remain unchanged.

3.7 CLTU-ASYNC-NOTIFY

3.7.1 PURPOSE

3.7.1.1 The FCLTU service provider shall invoke the CLTU-ASYNC-NOTIFY operation to notify the user of an event affecting the production of the FCLTU service.

NOTE – Notification of events may be of value to the user in understanding specific provider behavior, such as an interruption of the command radiation.

3.7.1.2 CLTU-ASYNC-NOTIFY shall be an unconfirmed operation.

NOTE – Notifications from the provider are delivered to the user asynchronously to the flow of CLTU-TRANSFER-DATA operations from the user to the provider.

3.7.1.3 The CLTU-ASYNC-NOTIFY operation is valid in states 2 ('ready') and 3 ('active') and shall be invoked only by the provider.

3.7.2 INVOCATION AND PARAMETERS

3.7.2.1 General

The parameters of the CLTU-ASYNC-NOTIFY operation shall be present in the invocation as specified in table 3-7.

Table 3-7: CLTU-ASYNC-NOTIFY Parameters

Parameters	Invocation
invoker-credentials	M
notification-type	M
event-thrown-identification	C
cltu-last-processed	M
cltu-last-OK	M
cltu-status	C
radiation-start-time	C
radiation-stop-time	C
production-status	M
uplink-status	M

3.7.2.2 invoker-credentials

The **invoker-credentials** parameter shall provide information that enables the performer to authenticate the CLTU-ASYNC-NOTIFY invocation (see 3.1.5).

3.7.2.3 notification-type

The **notification-type** parameter shall describe the event being notified to the user and shall contain one of the following values:

- a) 'cltu radiated'—the CLTU identified by the value of the `cltu-last-processed` parameter successfully completed radiation. This value of `notification-type` shall be used only if the value of `report` in the associated CLTU-TRANSFER-DATA invocation was 'produce report'.
- b) 'sldu expired'—radiation of the CLTU identified by the value of the `cltu-last-processed` parameter did not begin by the time specified in the `latest-radiation-time` parameter of the associated CLTU-TRANSFER-DATA invocation. No further CLTUs shall be radiated; buffered CLTUs shall be discarded; and further CLTU-TRANSFER-DATA invocations shall be blocked, i.e., rejected with `diagnostic` set to 'unable to process'.

NOTE – After the 'sldu expired' event, the service user has to clear the blocking by invoking a CLTU-STOP operation. In order to resume the transfer and radiation of CLTUs, the user subsequently needs to successfully invoke CLTU-START.

- c) 'production interrupted'—the production process has stopped due to a condition that may be temporary. This event occurs and the notification shall be sent
 - 1) for notification mode 'immediate' when `production-status` changes to 'interrupted'; or
 - 2) for notification mode 'deferred' when `production-status` is 'interrupted' and either `cltu-status` is 'radiation started' or the radiation of the CLTU has to be started based on the specified `earliest-radiation-time` and `latest-radiation-time` parameters.

No further CLTUs shall be radiated; buffered CLTUs shall be discarded; and, in state 3 ('active'), further CLTU-TRANSFER-DATA invocations shall be blocked, i.e., rejected with `diagnostic` set to 'unable to process'.

RECOMMENDED STANDARD FOR SLE FCLTU SERVICE

NOTE – The user can unblock the service instance by invoking a CLTU-STOP operation. After the condition causing the ‘production interrupted’ event is corrected, the provider notifies the user by means of a CLTU-ASYNC-NOTIFY invocation with `notification-type` set to ‘production operational’. The user can resume the transfer and radiation of CLTUs after successfully invoking CLTU-START.

d) ‘production halted’—the production process has been stopped by management action; `production-status` is ‘halted’. No further CLTUs shall be radiated; buffered CLTUs shall be discarded; and, in state 3 (‘active’), further CLTU-TRANSFER-DATA invocations shall be blocked, i.e., rejected with `diagnostic` set to ‘unable to process’.

NOTES

1 The production process enters the halted state (`production-status` is ‘halted’) by service management decision, for example in case of malfunctioning equipment.

2 After the ‘production halted’ event, the service user has to clear the blocking by invoking a CLTU-STOP operation. After management action to remove the ‘halted’ `production-status` condition, the user can resume the transfer and radiation of CLTUs by successful invocation of CLTU-START.

e) ‘production operational’—the production process is ready to radiate CLTUs and `production-status` has changed to ‘operational’.

NOTE – The production process achieves operational status (`production-status` is ‘operational’) after initial establishment of the uplink channel or following actions to restore production to operational status after a halt or an interruption.

f) ‘buffer empty’—the provider has no further CLTUs buffered for this service instance. This event shall not be notified if the empty buffer is the result of a CLTU-STOP operation or a CLTU-ASYNC-NOTIFY operation with a notification of ‘production interrupted’ or ‘production halted’.

g) ‘action list completed’—all actions initiated by the CLTU-THROW-EVENT operation identified by the `event-thrown-identification` parameter have successfully completed.

h) ‘action list not completed’—at least one of the actions initiated by the CLTU-THROW-EVENT operation identified in the `event-thrown-identification` parameter did not complete.

i) ‘event condition evaluated to false’—a required condition was false for the event that the CLTU-THROW-EVENT operation identified by the `event-thrown-`

identification parameter attempted to trigger. The actions associated with this event have not been performed.

3.7.2.4 **event-thrown-identification**

3.7.2.4.1 If notification-type is 'action list completed', 'action list not completed', or 'event condition evaluated to false', the **event-thrown-identification** parameter shall be present and indicate the event-invocation-identification value of the CLTU-THROW-EVENT invocation that triggered the actions whose results are reported.

3.7.2.4.2 For all other notifications, this parameter shall not be present.

3.7.2.5 **cltu-last-processed**

For all notifications, the **cltu-last-processed** parameter shall be present. Its value shall be set as follows:

- a) if the provider has processed (i.e., attempted to radiate) no CLTUs during this service instance, the value of the **cltu-last-processed** parameter shall be set to 'null';
- b) otherwise, the **cltu-last-processed** parameter shall specify the sequence number, that is, the **cltu-identification** parameter value, of the CLTU that the provider most recently processed or attempted to process, whether the CLTU was successfully radiated or an exception occurred.

3.7.2.6 **cltu-last-OK**

For all notifications, the **cltu-last-OK** parameter shall be present. Its value shall be set as follows:

- a) if no CLTUs have been successfully processed (i.e., radiated completely) during this service instance, the value of the **cltu-last-OK** parameter shall be set to 'null';
- b) otherwise, the **cltu-last-OK** parameter shall specify the sequence number, that is, the **cltu-identification** parameter value, of the CLTU that most recently was successfully radiated.

3.7.2.7 **cltu-status**

3.7.2.7.1 For all notifications, if the value of the **cltu-last-processed** parameter is 'null', the **cltu-status** parameter shall not be present.

3.7.2.7.2 Whenever the value of the `cltu-last-processed` parameter is not 'null', the `cltu-status` parameter shall be present and shall contain one of the following values representing the processing state of the CLTU identified by `cltu-last-processed`:

- a) 'radiated'—radiation of the CLTU completed without aborting: the CLTU is guaranteed to have been radiated nominally;
- b) 'expired'—the `latest-radiation-time` of the CLTU was reached before beginning radiation: the CLTU is guaranteed not to have been radiated;
- c) 'interrupted'—radiation of the CLTU started but did not complete because `production-status` became 'interrupted';
- d) 'radiation started'—radiation of the CLTU started but processing is not yet complete;
- e) 'radiation not started'—the provider attempted to process the CLTU but could not start radiation because `production-status` was 'interrupted'.

3.7.2.8 radiation-start-time

3.7.2.8.1 For all notifications, if the `cltu-last-processed` is 'null', the **radiation-start-time** parameter shall not be present.

3.7.2.8.2 Whenever `cltu-last-processed` is not 'null', the `radiation-start-time` parameter shall be present and shall contain the time at which radiation of the CLTU identified by `cltu-last-processed` started, subject to the following stipulations:

- a) nominally, the `radiation-start-time` parameter shall contain the radiation time of the leading edge of the first radiated bit of the CLTU;
- b) if the `cltu-status` value is 'expired' or 'production not started', the value of `radiation-start-time` shall be set to 'null'.

3.7.2.9 radiation-stop-time

3.7.2.9.1 For all notifications, if the `cltu-last-OK` is 'null', the **radiation-stop-time** parameter shall not be present.

3.7.2.9.2 Whenever `cltu-last-OK` is not 'null', the `radiation-stop-time` parameter shall be present and shall contain the time at which radiation of the CLTU identified by `cltu-last-OK` completed, i.e., the time of the trailing edge of the last radiated bit.

3.7.2.10 production-status

The **production-status** parameter shall describe the current status of the production process and shall contain one of the following values:

- a) ‘configured’—equipment has been assigned to support the service instance, but the production process is not yet capable of radiating CLTUs;
- b) ‘operational’—the production process has been configured for support and is capable of radiating CLTUs;
- c) ‘interrupted’—the production process has detected a problem that prevents it from radiating CLTUs; the problem may be transient and may be cleared for instance by automatic equipment reconfiguration;
- d) ‘halted’—service management has taken the production process out of service for instance because the problem that caused **production-status** to change to ‘interrupted’ is more severe and not of transient nature or because the resources have to be re-assigned.

3.7.2.11 uplink-status

3.7.2.11.1 The **uplink-status** parameter shall report to the user the state of the forward link obtained from the CLCW present in the return telemetry stream from the spacecraft.

3.7.2.11.2 The **uplink-status** parameter shall contain one of the following values:

- a) ‘uplink status not available’—no CLCWs from the spacecraft have been received by the provider;
- b) ‘no rf available’—the provider has received at least one CLCW; in the last CLCW received by the provider, the bit that flags ‘No RF Available’ was set to ‘1’;
- c) ‘no bit lock’—the provider has received at least one CLCW; in the last CLCW received by the provider, the bit that flags ‘No RF Available’ was set to ‘0’, and the bit that flags ‘No Bit Lock’ was set to ‘1’;
- d) ‘nominal’—the provider has received at least one CLCW; in the last CLCW received by the provider, the bit that flags ‘No RF Available’ was set to ‘0’, and the bit that flags ‘No Bit Lock’ was set to ‘0’.

3.7.3 EFFECTS

3.7.3.1 If **notification-type** indicates ‘sldu expired’, ‘production interrupted’, or ‘production halted’:

- a) no further CLTUs shall be radiated;

RECOMMENDED STANDARD FOR SLE FCLTU SERVICE

- b) buffered CLTUs shall be discarded; and
- c) further CLTU-TRANSFER-DATA invocations shall be rejected.

3.7.3.2 There shall be no effect for any other values of `notification-type`.

3.7.3.3 The provider state shall remain unchanged.

3.8 CLTU-SCHEDULE-STATUS-REPORT

3.8.1 PURPOSE

3.8.1.1 The user shall invoke the CLTU-SCHEDULE-STATUS-REPORT operation to request that the provider do one of the following:

- a) send a status report immediately (see 3.9);
- b) send periodic status reports (see 3.9); or
- c) stop sending periodic status reports.

3.8.1.2 The provider shall return a report of the outcome of the performance of the CLTU-SCHEDULE-STATUS-REPORT operation to the user.

3.8.1.3 Initially (i.e., whenever the CLTU-BIND operation is performed and the provider transitions from state 1 to state 2), periodic reporting shall be inactive.

3.8.1.4 For periodic reporting, the user may change the reporting period by invoking another CLTU-SCHEDULE-STATUS-REPORT operation.

3.8.1.5 The CLTU-SCHEDULE-STATUS-REPORT operation is valid only in states 2 ('ready') and 3 ('active') and shall be invoked only by the user.

3.8.2 INVOCATION, RETURN, AND PARAMETERS

3.8.2.1 General

The parameters of the CLTU-SCHEDULE-STATUS-REPORT operation shall be present in the invocation and return as specified in table 3-8.

Table 3-8: CLTU-SCHEDULE-STATUS-REPORT Parameters

Parameters	Invocation	Return
invoker-credentials	M	
performer-credentials		M
invoke-ID	M	M
report-request-type	M	
reporting-cycle	C	
result		M
diagnostic		C

3.8.2.2 **invoker-credentials**

The **invoker-credentials** parameter shall provide information that enables the performer to authenticate the CLTU-SCHEDULE-STATUS-REPORT invocation (see 3.1.5).

3.8.2.3 **performer-credentials**

The **performer-credentials** parameter shall contain information that enables the invoker to authenticate the return from the performance of CLTU-SCHEDULE-STATUS-REPORT (see 3.1.5).

3.8.2.4 **invoke-ID**

The performer shall return unchanged the invoker-supplied value of the **invoke-ID** parameter (see 3.1.6).

3.8.2.5 **report-request-type**

3.8.2.5.1 The **report-request-type** parameter shall specify how reporting shall be done, and its value shall be one of the following:

- a) 'immediately'—send a single status report immediately;
- b) 'periodically'—send a status report every `reporting-cycle` seconds;
- c) 'stop'—do not send further status reports.

3.8.2.5.2 If `report-request-type` is 'immediately',

- a) the provider shall send a status report immediately;
- b) the provider shall stop sending status reports after the immediate status report has been sent.

NOTE – Periodic reporting may be (re-)started by means of another CLTU-SCHEDULE-STATUS-REPORT invocation.

3.8.2.6 **reporting-cycle**

3.8.2.6.1 If the value of the `report-request-type` parameter is 'periodically', then the **reporting-cycle** parameter shall be present and shall specify the requested interval between status reports in seconds.

3.8.2.6.2 If the value of the `report-request-type` parameter is not 'periodically', the `reporting-cycle` parameter shall not be present.

3.8.2.7 result

The **result** parameter shall specify the result of the CLTU-SCHEDULE-STATUS-REPORT operation, and its value shall be one of the following:

- a) 'positive result'—the CLTU-SCHEDULE-STATUS-REPORT operation has been performed, and the provider will send the requested status report(s) or stop sending periodic status reports;
- b) 'negative result'—the CLTU-SCHEDULE-STATUS-REPORT operation has not been performed for the reason specified in the **diagnostic** parameter; the previous setting for status reporting remains in effect.

3.8.2.8 diagnostic

3.8.2.8.1 If **result** is 'negative result', **diagnostic** shall be present in the return and its value shall be one of the following:

- a) 'duplicate invoke-ID'—the value of the **invoke-ID** parameter is the same as the **invoke-ID** value of a previous, outstanding operation;
- b) 'already stopped'—the provider is not currently providing periodic reports (applicable only when **report-request-type** is 'stop');
- c) 'invalid reporting cycle'—the **reporting-cycle** value is outside the range agreed upon by service management;
- d) 'other reason'—the reason for the negative result will have to be found by other means.

3.8.2.8.2 If **result** is 'positive result', **diagnostic** shall not be present.

3.8.3 EFFECTS

3.8.3.1 If **result** is 'positive result', the CLTU-SCHEDULE-STATUS-REPORT operation shall have the following effects, depending on the value of the **report-request-type** parameter:

- a) if **report-request-type** is 'immediately':
 - 1) a status report shall be sent immediately, i.e., the provider shall invoke a CLTU-STATUS-REPORT operation;
 - 2) the sending of any previously requested periodic status reports shall cease;
- b) if **report-request-type** is 'periodically':

RECOMMENDED STANDARD FOR SLE FCLTU SERVICE

- 1) a status report shall be sent immediately, i.e., the provider shall invoke a CLTU-STATUS-REPORT operation;
- 2) subsequent status reports shall be sent at the interval specified in the `reporting-cycle` parameter;
- c) if `report-request-type` is 'stop', periodic reporting shall cease.

3.8.3.2 If `result` is 'negative result', the CLTU-SCHEDULE-STATUS-REPORT operation shall have no effect, and the previous setting for the status reporting shall not change.

3.8.3.3 The provider state shall remain unchanged.

3.9 CLTU-STATUS-REPORT

3.9.1 PURPOSE

3.9.1.1 The provider shall invoke the CLTU-STATUS-REPORT operation to send a status report to the user.

3.9.1.2 CLTU-STATUS-REPORT shall be an unconfirmed operation.

3.9.1.3 Status reports shall be sent (or not sent) in accordance with user requests conveyed by means of the CLTU-SCHEDULE-STATUS-REPORT operation (see 3.8).

3.9.1.4 The CLTU-STATUS-REPORT operation is valid only in states 2 ('ready') and 3 ('active') and shall be invoked only by the provider.

3.9.2 INVOCATION AND PARAMETERS

3.9.2.1 General

The parameters of the CLTU-STATUS-REPORT operation shall be present in the invocation as specified in table 3-9.

Table 3-9: CLTU-STATUS-REPORT Parameters

Parameters	Invocation
invoker-credentials	M
cltu-last-processed	M
cltu-last-OK	M
cltu-status	C
radiation-start-time	C
radiation-stop-time	C
production-status	M
uplink-status	M
number-of-cltus-received	M
number-of-cltus-processed	M
number-of-cltus-radiated	M
cltu-buffer-available	M

3.9.2.2 **invoker-credentials**

The **invoker-credentials** parameter shall provide information that enables the performer to authenticate the CLTU-STATUS-REPORT invocation (see 3.1.5).

3.9.2.3 **cltu-last-processed**

3.9.2.3.1 If the provider has processed (i.e., attempted to radiate) no CLTUs during this service instance, **cltu-last-processed** shall be set to ‘null’.

3.9.2.3.2 Otherwise, the **cltu-last-processed** parameter shall specify the sequence number, i.e., the **cltu-identifier** parameter value, of the CLTU that the provider most recently processed or attempted to process, whether the CLTU was successfully radiated or an exception occurred.

3.9.2.4 **cltu-last-OK**

3.9.2.4.1 If no CLTUs have been successfully processed (i.e., radiated completely) during this service instance, **cltu-last-OK** shall be set to ‘null’.

3.9.2.4.2 Otherwise, the **cltu-last-OK** parameter shall specify the sequence number, i.e., the **cltu-identifier** parameter value, of the CLTU that most recently was successfully radiated.

3.9.2.5 **cltu-status**

3.9.2.5.1 If **cltu-last-processed** is ‘null’, the **cltu-status** parameter shall not be present.

3.9.2.5.2 Whenever the value of the **cltu-last-processed** parameter is not ‘null’, the **cltu-status** parameter shall be present and shall contain one of the following values representing the processing state of the CLTU identified by **cltu-last-processed**:

- a) ‘radiated’—radiation of the CLTU completed without aborting: the CLTU is guaranteed to have been radiated nominally;
- b) ‘expired’—the **latest-radiation-time** of the CLTU was reached before beginning radiation: the CLTU is guaranteed not to have been radiated;
- c) ‘interrupted’—radiation of the CLTU was aborted when the **production-status** parameter value changed from ‘operational’ to ‘interrupted’: status information available to the provider indicates that the CLTU started radiating and aborted prior to nominal completion;
- d) ‘radiation started’—radiation of the CLTU started but processing is not yet complete;

- e) 'radiation not started'—the reported CLTU did not start radiation: the CLTU was blocked because `production-status` was 'interrupted'.

3.9.2.6 `radiation-start-time`

3.9.2.6.1 If `cltu-last-processed` is 'null', the **`radiation-start-time`** parameter shall not be present.

3.9.2.6.2 Whenever `cltu-last-processed` is not 'null', the `radiation-start-time` parameter shall be present and shall contain the time at which radiation of the CLTU identified by `cltu-last-processed` started, subject to the following stipulations:

- a) nominally, the `radiation-start-time` parameter shall contain the radiation time of the leading edge of the first radiated bit of the CLTU;
- b) if `cltu-status` is 'expired' or 'radiation not started', `radiation-start-time` shall be set to 'null'.

3.9.2.7 `radiation-stop-time`

3.9.2.7.1 If `cltu-last-OK` is 'null', the **`radiation-stop-time`** parameter shall not be present.

3.9.2.7.2 Whenever `cltu-last-OK` is not 'null', the `radiation-stop-time` parameter shall be present and shall contain the time at which radiation of the CLTU identified by `cltu-last-OK` completed, i.e., the time of the trailing edge of the last radiated bit.

3.9.2.8 `production-status`

The **`production-status`** parameter shall describe the current status of the production process and shall contain one of the following values:

- a) 'configured'—equipment has been assigned to support the service instance, but the production process is not yet capable of radiating CLTUs;
- b) 'operational'—the production process has been configured for support, has completed the acquisition sequence, and is capable of radiating CLTUs;
- c) 'interrupted'—the production process is stopped due to a fault;
- d) 'halted'—the production process is stopped and production equipment is out of service due to management action.

3.9.2.9 **uplink-status**

3.9.2.9.1 The **uplink-status** parameter shall report to the user the state of the forward link obtained from the CLCW present in the return telemetry stream from the spacecraft.

3.9.2.9.2 The **uplink-status** parameter shall contain one of the following values:

- a) ‘uplink status not available’—no CLCWs from the spacecraft have been received by the provider;
- b) ‘no rf available’—the provider has received at least one CLCW; in the last CLCW received by the provider, the bit that flags ‘No RF Available’ was set to ‘1’;
- c) ‘no bit lock’—the provider has received at least one CLCW; in the last CLCW received by the provider, the bit that flags ‘No RF Available’ was set to ‘0’, and the bit that flags ‘No Bit Lock’ was set to ‘1’;
- d) ‘nominal’—the provider has received at least one CLCW; in the last CLCW received by the provider, the bit that flags ‘No RF Available’ was set to ‘0’, and the bit that flags ‘No Bit Lock’ was set to ‘0’.

3.9.2.10 **number-of-cltus-received**

3.9.2.10.1 The **number-of-cltus-received** parameter shall specify the total number of CLTUs received during this service instance.

3.9.2.10.2 Only CLTUs that are checked successfully and buffered shall be counted in the total.

3.9.2.10.3 If no CLTUs have been received, the value of this parameter shall be zero (‘0’).

3.9.2.11 **number-of-cltus-processed**

3.9.2.11.1 The **number-of-cltus-processed** parameter shall specify the number of CLTUs that the provider attempted to radiate during this service instance, including

- CLTUs that radiated successfully;
- CLTUs that expired;
- CLTUs that aborted;
- a CLTU in the process of being radiated.

3.9.2.11.2 If no CLTUs have been processed, the value of this parameter shall be zero (‘0’).

3.9.2.12 number-of-cltus-radiated

3.9.2.12.1 The **number-of-cltus-radiated** shall contain the count of CLTUs successfully radiated during this service instance.

3.9.2.12.2 A CLTU in the process of being radiated shall not be included in this count.

3.9.2.12.3 If no CLTUs have been radiated, the value of this parameter shall be zero ('0').

3.9.2.13 cltu-buffer-available

3.9.2.13.1 The **cltu-buffer-available** parameter shall specify the remaining number of octets available for buffering CLTUs.

3.9.2.13.2 Once the provider starts to process a CLTU, it shall be considered removed from the buffer.

3.9.3 EFFECTS

The CLTU-STATUS-REPORT operation shall have the following effects:

3.9.3.1 Status information shall be delivered to the user.

3.9.3.2 The provider state shall remain unchanged.

3.10 CLTU-GET-PARAMETER

3.10.1 PURPOSE

3.10.1.1 The user shall invoke the CLTU-GET-PARAMETER operation to ascertain the value of an FCLTU service parameter.

3.10.1.2 The provider shall return a report of the outcome of the performance of the CLTU-GET-PARAMETER operation to the user.

3.10.1.3 If the operation is successful, the current value of the specified FCLTU service parameter shall be provided to the user in the return from the operation.

3.10.1.4 The CLTU-GET-PARAMETER operation is valid only in states 2 ('ready') and 3 ('active') and shall be invoked only by the user.

3.10.2 INVOCATION, RETURN, AND PARAMETERS

3.10.2.1 General

The parameters of the CLTU-GET-PARAMETER operation shall be present in the invocation and return as specified in table 3-10.

Table 3-10: CLTU-GET-PARAMETER Parameters

Parameters	Invocation	Return
invoker-credentials	M	
performer-credentials		M
invoke-ID	M	M
cltu-parameter	M	C
parameter-value		C
result		M
diagnostic		C

3.10.2.2 invoker-credentials

The **invoker-credentials** parameter shall provide information that enables the performer to authenticate the CLTU-GET-PARAMETER invocation (see 3.1.5).

3.10.2.3 performer-credentials

The **performer-credentials** parameter shall provide information that enables the invoker to authenticate the return from the performance of CLTU-GET-PARAMETER (see 3.1.5).

3.10.2.4 invoke-ID

The performer shall return unchanged the invoker-supplied value of the **invoke-ID** parameter (see 3.1.6).

3.10.2.5 cltu-parameter

3.10.2.5.1 The **cltu-parameter** parameter shall specify the FCLTU service parameter whose value is to be returned to the user, and its value shall be one of the values listed in table 3-11.

3.10.2.5.2 **cltu-parameter** is conditionally present in the return based on the value of the **result** parameter:

- a) if **result** is 'positive result', **cltu-parameter** shall be present in the return;
- b) if **result** is 'negative result', **cltu-parameter** shall not be present in the return.

3.10.2.6 parameter-value

3.10.2.6.1 The **parameter-value** parameter shall contain the value of the FCLTU service parameter indicated by **cltu-parameter** (see 3.10.2.5).

3.10.2.6.2 The **parameter-value** parameter is conditionally present in the return based on the value of **result** parameter:

- a) if **result** is 'positive result', **parameter-value** shall be present;
- b) if **result** is 'negative result', **parameter-value** shall not be present.

3.10.2.7 result

The **result** parameter shall specify the result of the CLTU-GET-PARAMETER invocation and shall contain one of the following values:

- a) 'positive result'—the CLTU-GET-PARAMETER operation has been performed, and the value of the specified FCLTU service parameter is provided in the return to the user;

RECOMMENDED STANDARD FOR SLE FCLTU SERVICE

- b) ‘negative result’—the CLTU-GET-PARAMETER operation has not been performed for the reason specified in the `diagnostic` parameter.

Table 3-11: FCLTU Service Parameters

Parameter	Description
<code>acquisition-sequence-length</code>	The size, in octets, of the bit pattern to be radiated to enable the spacecraft telecommand system to achieve bit lock.
<code>bit-lock-required</code>	If the value is ‘yes’, the ‘No bit lock’ flag in the CLCW must be false in order for the provider to set <code>production-status</code> to ‘operational’.
<code>clcw-global-VCID</code>	The Master Channel or Virtual Channel that carries the CLCW to be used by the FCLTU service provider to determine the forward link RF and/or bit lock status. If the configuration of the given service instance is such that the CLCW shall not be evaluated then the parameter value reported is ‘not configured’.
<code>clcw-physical-channel</code>	The RF return channel that carries the CLCW to be used by the FCLTU service provider to determine the forward link RF and bit lock status. This parameter implicitly specifies the applicable Transfer Frame version to be handled: TM, AOS, USLP fixed-length frame, or USLP variable-length frame. If the configuration of the given service instance is such that the CLCW shall not be evaluated then the parameter value reported is ‘not configured’.
<code>delivery-mode</code>	‘fwd online’
<code>expected-cltu-identification</code>	The expected value of the <code>cltu-identification</code> parameter to be received in the next CLTU-TRANSFER-DATA invocation. If no CLTU-START has been received, zero (‘0’) shall be returned as the default value of this parameter.
<code>expected-event-invocation-identification</code>	The expected value of the <code>event-invocation-identification</code> parameter to be received in the next CLTU-THROW-EVENT invocation. The initial value of this parameter is zero (‘0’).
<code>maximum-cltu-length</code>	The size, in octets, of the maximum-length CLTU that will be accepted by the provider for this service instance.
<code>minimum-delay-time</code>	The minimum guard time the FCLTU service provider will accept between two consecutive CLTUs.
<code>minimum-reporting-cycle</code>	The minimum setting (in seconds) of <code>reporting-cycle</code> for status reports that the FCLTU service user may request in a CLTU-SCHEDULE-STATUS-REPORT invocation.

RECOMMENDED STANDARD FOR SLE FCLTU SERVICE

Parameter	Description
modulation-frequency	The subcarrier frequency (when applicable) or the frequency of direct-on-carrier data modulation, expressed in tenths of Hertz.
modulation-index	The peak angle by which the RF carrier is phase shifted with respect to the un-modulated RF carrier, expressed in milliradians (10^{-3} rad).
notification-mode	The notification-mode may be 'immediate' or 'deferred'. If 'immediate', the user is notified of a <code>production-status</code> change to 'interrupted' by means of a <code>CLTU-ASYNC-NOTIFY</code> invocation as soon as this transition is detected. If 'deferred', the user is notified about the <code>production-status</code> change to 'interrupted' by means of a <code>CLTU-ASYNC-NOTIFY</code> invocation only if and when the radiation of a CLTU is affected.
plop-1-idle-sequence-length	The size, in octets, of the optional idle sequence that shall be used in conjunction with PLOP-1. If '0', no idle sequence is applied.
plop-in-effect	The PLOP being used: 'PLOP-1' or 'PLOP-2'.
protocol-abort-mode	The <code>protocol-abort-mode</code> may be 'abort' or 'continue'. If it is 'abort', service production shall cease in the event of a protocol abort. If it is 'continue', service production shall disregard this event and continue radiating the CLTUs already buffered at that time.
reporting-cycle	The current setting of <code>reporting-cycle</code> for status reports as reported by the <code>current-reporting-cycle</code> parameter: the value is 'null' if cyclic reporting is off, otherwise it is the time (in seconds) between successive <code>CLTU-STATUS-REPORT</code> invocations (see 3.8). As long as the FCLTU service user has not yet set this parameter by means of a successful <code>CLTU-SCHEDULE-STATUS-REPORT</code> operation, its value shall be 'null'.
return-timeout-period	The maximum time period (in seconds) permitted from when a confirmed FCLTU service operation is invoked until the return is received by the invoker (see 4.1.3).
rf-available-required	If the value is 'yes', the 'No RF available' flag in the CLCW must be false in order for the provider to set <code>production-status</code> to 'operational'.
subcarrier-to-bit-rate-ratio	When subcarrier modulation is used, the value represents the ratio of the subcarrier frequency to the uplink data rate (i.e., the bit rate). A value of one indicates that data will be directly modulated onto the carrier.

3.10.2.8 diagnostic

3.10.2.8.1 If `result` is 'negative result', **diagnostic** shall be present and shall contain one of the following values:

- a) 'duplicate invoke-ID'—the value of the `invoke-ID` parameter is the same as the `invoke-ID` value of a previous, outstanding operation;
- b) 'unknown parameter'—the value of the `cltu-parameter` parameter does not identify an FCLTU service parameter that is recognized by the service provider;
- c) 'other reason'—the reason for the negative result will have to be found by other means.

3.10.2.8.2 If `result` is 'positive result', **diagnostic** shall not be present in the return.

3.10.3 EFFECTS

3.10.3.1 If `result` is 'positive result', the value of the FCLTU service parameter specified by the `cltu-parameter` parameter shall be returned to the user in the return.

3.10.3.2 If `result` is 'negative result', no FCLTU service parameter specified by the `cltu-parameter` parameter shall be returned to the user.

3.10.3.3 The provider state shall remain unchanged.

3.11 CLTU-THROW-EVENT

3.11.1 PURPOSE

3.11.1.1 The user shall invoke the CLTU-THROW-EVENT operation in order to cause the provider to forward to SLE Complex Management an event that requires management action.

NOTES

- 1 An example of such an event is change of the uplink bit rate. This will typically require sending a telecommand that reconfigures the spacecraft commanding system to the new bit rate. When this command has been executed, the uplink bit rate setting of the FCLTU service production can be changed accordingly by throwing the associated event.
- 2 The event is considered to occur when the user invokes the CLTU-THROW-EVENT operation, i.e., the provider is expected to react to the receipt of a CLTU-THROW-EVENT invocation with minimal delay. It is therefore asynchronous with the radiation of SL-DUs.
- 3 If synchronism is required between the event and the radiation of a specific SL-DU, it is the user's responsibility to ensure that, e.g., by means of controlling the radiation time of the critical CLTUs or by means of the notification capabilities provided by the FCLTU service.

3.11.1.2 The performer shall return a report of the outcome of the performance of the CLTU-THROW-EVENT operation to the user.

NOTE – The return will only show whether the invocation itself has been accepted or rejected, but not if the actions associated with the event have been performed successfully. The provider will invoke a CLTU-ASYNC-NOTIFY operation to inform the user on the outcome of the actions triggered by the event.

3.11.1.3 The CLTU-THROW-EVENT operation is valid in states 2 ('ready') and 3 ('active') and shall be invoked only by the user.

3.11.2 INVOCATION, RETURN, AND PARAMETERS

3.11.2.1 General

The parameters of the CLTU-THROW-EVENT operation shall be present in the invocation and return as specified in table 3-12.

3.11.2.2 invoker-credentials

The **invoker-credentials** parameter shall provide information that enables the performer to authenticate the CLTU-THROW-EVENT invocation (see 3.1.5).

3.11.2.3 performer-credentials

The **performer-credentials** parameter shall provide information that enables the invoker to authenticate the return from the performance of CLTU-THROW-EVENT (see 3.1.5).

3.11.2.4 invoke-ID

The performer shall return unchanged the invoker-supplied value of the **invoke-ID** parameter (see 3.1.6).

Table 3-12: CLTU-THROW-EVENT Parameters

Parameters	Invocation	Return
invoker-credentials	M	
performer-credentials		M
invoke-ID	M	M
event-invocation-identification	M	M
event-identifier	M	
event-qualifier	M	
result		M
diagnostic		C

3.11.2.5 event-invocation-identification

3.11.2.5.1 The **event-invocation-identification** parameter shall contain a monotonically increasing sequence number and shall be

- a) set to zero ('0') for the first CLTU-THROW-EVENT invocation following the first successful CLTU-BIND to the service instance;
- b) incremented for each CLTU-THROW-EVENT invocation accepted by the provider.

3.11.2.5.2 The provider shall set the value of the `event-invocation-identification` parameter to the sequence number expected in the next `CLTU-THROW-EVENT` invocation:

- a) if the invocation is accepted, the value of `event-invocation-identification` in the return shall be one greater than the value in the invocation;
- b) if the invocation is rejected, the `event-invocation-identification` in the return shall contain the value expected by the FCLTU service provider:
 - 1) in the case of the first `CLTU-THROW-EVENT` operation following a successful `CLTU-BIND` operation, it is zero ('0');
 - 2) otherwise, the value is one greater than the value of the `event-invocation-identification` parameter of the last accepted `CLTU-THROW-EVENT` operation.

3.11.2.5.3 The user shall set the value of `event-invocation-identification` in the next `CLTU-THROW-EVENT` invocation to the value returned by the provider.

3.11.2.5.4 The value expected by the provider for the given service instance shall not be altered when the association between user and provider is reestablished after being released or aborted.

3.11.2.5.5 The provider shall use the user-supplied value of `event-invocation-identification` to reference the respective event in all subsequent reports.

3.11.2.6 event-identifier

The **event-identifier** parameter shall identify the event to be forwarded to SLE Complex Management by the service provider.

3.11.2.7 event-qualifier

The **event-qualifier** parameter may be used to provide additional data constraining the actions to be performed by Complex Management in response to the event specified in `event-identifier` and shall be forwarded together with the event.

NOTES

- 1 For example, `event-identifier` may be 'bit-rate-change'. Then `event-qualifier` may specify the new bit rate.

- 2 The **actual** type and any constraints applicable to the data contained in the `event-qualifier` parameter depend on the event. These have to be checked by Complex Management. The FCLTU service provider only checks that the **formal** type (octet string) and the length of this parameter are in line with the specification in annex A.

3.11.2.8 result

The **result** parameter shall specify the result of the CLTU-THROW-EVENT invocation and shall contain one of the following values:

- a) ‘positive result’—the CLTU-THROW-EVENT operation has been performed and the event together with the associated qualifier will be forwarded to SLE Complex Management;
- b) ‘negative result’—the CLTU-THROW-EVENT operation has not been performed for the reason specified in the `diagnostic` parameter. The provider will not forward the event to Complex Management.

3.11.2.9 diagnostic

3.11.2.9.1 If `result` is ‘negative result’, **diagnostic** shall be present in the return, and its value shall be one of the following:

- a) ‘duplicate invoke-ID’—the value of the `invoke-ID` parameter is the same as the `invoke-ID` value of a previous, outstanding operation;
- b) ‘operation not supported’—the CLTU-THROW-EVENT operation is not supported by the provider;
- c) ‘out of sequence’—the value of the `event-invocation-identification` parameter is not equal to the value expected by the provider;
- d) ‘no such event’—the value of the `event-identifier` parameter in the CLTU-THROW-EVENT invocation is not in the set of `event-identifier` values recognized by SLE Complex Management;
- e) ‘other reason’—the reason for the negative result will have to be found by other means.

3.11.2.9.2 If `result` is ‘positive result’, `diagnostic` shall not be present in the return.

3.11.3 EFFECTS

3.11.3.1 If `result` is ‘positive result’ the CLTU-THROW-EVENT operation shall have the following effects:

RECOMMENDED STANDARD FOR SLE FCLTU SERVICE

- a) the `event-identifier` and the `event-qualifier` parameters shall be forwarded, with minimum delay, to the event handler within SLE Complex Management;
- b) the provider shall pass notifications received from the event handler to the user by invoking the `CLTU-ASYNC-NOTIFY` operation.

NOTES

- 1 In order for the `CLTU-THROW-EVENT` to have an effect, there must be prior agreement between SLE Complex Management and SLE Utilization Management regarding the definition of event identifiers and the interpretation of any accompanying qualifying parameter.
- 2 The effects of the event thrown may consist of preparations made for a change to be triggered by a later `CLTU-THROW-EVENT` invocation.
- 3 Checking of the `event-qualifier` parameter may be performed within SLE Complex Management. If an error is found, `CLTU-ASYNC-NOTIFY` is sent to the user with the notification 'action list not completed'.

3.11.3.2 If `result` is 'negative result', the event shall not be forwarded to SLE Complex Management.

3.11.3.3 The provider state shall remain unchanged.

3.12 CLTU-PEER-ABORT

3.12.1 PURPOSE

3.12.1.1 The user or provider shall invoke the CLTU-PEER-ABORT operation to notify the peer system that the local application detected an error that requires that the association between them be terminated abnormally.

3.12.1.2 CLTU-PEER-ABORT shall be an unconfirmed operation.

3.12.1.3 The CLTU-PEER-ABORT operation should be truly abortive, i.e., the transfer of the SLE-PDU carrying this invocation should not be delayed by other invocations submitted earlier and possibly being buffered by the underlying communications service.

3.12.1.4 The CLTU-PEER-ABORT operation is valid in states 2 ('ready') and 3 ('active') and may be invoked in these states by either the user or the provider.

3.12.1.5 The CLTU-PEER-ABORT operation may be invoked by the user in state 1 ('unbound') subsequent to invocation of the CLTU-BIND operation, when the return is not received within the specified time limit (see 4.1.3).

3.12.2 INVOCATION AND PARAMETERS

3.12.2.1 General

The parameters of the CLTU-PEER-ABORT operation shall be present in the invocation as specified in table 3-13.

Table 3-13: CLTU-PEER-ABORT Parameters

Parameters	Invocation
diagnostic	M

3.12.2.2 diagnostic

The **diagnostic** parameter shall specify why the CLTU-PEER-ABORT is being issued and shall contain one of the following values:

- a) 'access denied'—a responder with an identity as presented in the `responder-identifier` parameter of the CLTU-BIND return is not registered at the initiator;
- b) 'unexpected responder ID'—the value of the `responder-identifier` parameter in the CLTU-BIND return does not match the identifier of the authorized responder for this service instance as specified by service management;

- c) ‘operational requirement’—the local system had to terminate the association to accommodate some other operational need;
- d) ‘protocol error’—the local application entity detected an error in the sequencing of FCLTU service operations;
- e) ‘communications failure’—the communications service on the other side of a gateway was disrupted;

NOTE – This diagnostic value is only applicable when the SLE applications entities are communicating via a gateway.

- f) ‘encoding error’—the local application entity detected an error in the encoding of one or more operation parameters or did not recognize the operation;
- g) ‘return timeout’—the local application entity detected that the return from a confirmed operation was not received within the time specified by the return-timeout-period parameter (see 4.1.3);
- h) ‘end of service instance provision period’—the local application entity detected that the service instance provision period has ended, and the initiator has not invoked the CLTU-UNBIND operation;
- i) ‘unsolicited invoke-ID’—the local application entity received a return with an `invoke-ID` value that does not match with the `invoke-ID` parameter value of any of the operations for which the return is pending;
- j) ‘other reason’—the local application detected an unspecified error during the processing of one or more operations.

NOTE – CLTU-PEER-ABORT does not carry an `invoker-credentials` parameter. It is conceivable that an intruder might use the CLTU-PEER-ABORT operation for a denial-of-service attack. If an intruder has this capability of breaking into an existing connection, then a denial-of-service attack can be much more easily accomplished by disrupting communications at a layer lower than the application layer. Therefore, authentication of the CLTU-PEER-ABORT operation would not provide improved protection against such attacks.

3.12.3 EFFECTS

The CLTU-PEER-ABORT operation shall have the following effects:

- a) the association between the initiator and the responder shall be aborted, and the initiator and the responder shall cease to communicate with each other;
- b) the provider shall transition to state 1 (‘unbound’);
- c) the provider shall discard buffered CLTUs;

RECOMMENDED STANDARD FOR SLE FCLTU SERVICE

- d) the provider shall stop production, except for a CLTU in the process of being radiated;
- e) the initiator may attempt to re-bind at any time prior to the end of the provision period scheduled for this service instance;
- f) statistical information required for the generation of status reports shall be retained throughout the service instance provision period;
- g) parameters that serve to relate notifications on an activity to operations that triggered that activity shall not be altered when the association is aborted.

4 CLTU PROTOCOL

4.1 GENERIC PROTOCOL CHARACTERISTICS

NOTE – This section specifies the handling of invalid SLE-PDUs and other failures affecting the protocol.

4.1.1 UNEXPECTED SLE PROTOCOL DATA UNIT

If the peer application entity sends an invocation or return not allowed in the current state of the performer, the performer shall abort the association by invoking the CLTU-PEER-ABORT operation with the `diagnostic` parameter set to ‘protocol error’.

4.1.2 INVALID OR UNDECODABLE PROTOCOL DATA UNIT

If the application entity receives an invocation or return that contains an unrecognized operation type, contains a parameter of a wrong type, or is otherwise not decodable, the application entity shall abort the association by invoking the CLTU-PEER-ABORT operation with the `diagnostic` parameter set to ‘encoding error’.

4.1.3 MISSING RETURN

For confirmed operations, if the invoker does not receive the return from the performer within the return-timeout-period specified by service management, the invoker shall abort the association by invoking the CLTU-PEER-ABORT operation with the `diagnostic` parameter set to ‘return timeout’.

NOTES

- 1 The return-timeout-period shall be chosen taking into account performance of user and provider applications as well as the delays introduced by the underlying communications service.
- 2 In order to provide responsive service and short return-timeout-periods, the generation of the return from an operation must not depend on any human interaction.
- 3 After invoking the CLTU-UNBIND operation, the initiator must not invoke any further operations with the exception of the case addressed in 3.3.1.4 nor send any returns. The responder is not required to send any pending returns after having received the CLTU-UNBIND invocation. Therefore, following a CLTU-UNBIND invocation, the ‘return timeout’ CLTU-PEER-ABORT may be triggered by a missing return.

4.1.4 UNSOLICITED RETURN

If the application entity receives a return with an `invoke-ID` parameter value that does not correspond to any invocation for which the return is still pending, the application entity shall abort the association by invoking the `CLTU-PEER-ABORT` operation with the `diagnostic` parameter set to 'unsolicited invoke-ID'.

4.1.5 COMMUNICATIONS FAILURE

4.1.5.1 Every SLE entity (i.e., every SLE user or provider) that is in an association (bound) with a peer SLE entity shall maintain knowledge of the health of the communications interface with the peer.

4.1.5.2 If an SLE entity is informed by its underlying communications service that communications with the peer entity have been disrupted (e.g., due to a communications failure), then this entity shall consider that the association with the peer entity has been aborted. Occurrence of such communications failure event shall be referred to as a 'protocol abort'.

NOTE – The exact criteria for determining when communications have been disrupted may depend on the characteristics of the communications service and may be specific to a given implementation. However, it is a firm requirement on any communications service underlying an SLE transfer service that it includes suitable means to ascertain the status of the connection (see 1.3.1). In the case of communications protocols that do not intrinsically provide such a capability, the transmission of a periodic 'heartbeat' indicator or equivalent may need to be implemented.

4.1.5.3 Subsequent to a 'protocol abort' event:

- a) the provider shall transition to state 1 ('unbound');
- b) the provider shall complete processing of a CLTU in the process of being radiated;
- c) if the value of the `protocol-abort-mode` parameter (see 3.1.10) is 'flush', all buffered CLTUs shall be discarded;
- d) if the value of the `protocol-abort-mode` parameter is 'continue', buffered CLTUs shall not be discarded, and CLTUs shall continue to be processed as though the association had not been aborted;
- e) neither the user nor the provider shall attempt further communications with the peer except that the user may attempt to re-establish the association by invoking the `CLTU-BIND` operation.

NOTES

- 1 When the CLTU buffer is not flushed following occurrence of a protocol abort, any notifications (e.g., 'cltu radiated') generated while the association is not available shall not cause the invocation of a CLTU-ASYNC-NOTIFY operation. Neither shall such CLTU-ASYNC-NOTIFY operations be buffered such that they can be invoked if the user should later re-BIND to the service instance. It is recommended, but not required, that such notifications be logged and thus available to the user via Service Management. The user, on the basis of the information conveyed by a CLTU-STATUS-REPORT when the association is re-established, can determine which CLTUs were successfully radiated.
- 2 In addition, when the CLTU buffer is not flushed following a protocol abort, if the user subsequently re-BINDs to the service instance, it is the user's responsibility to choose a `first-cltu-identification` value in the CLTU-START that is greater than the `cltu-identification` value of any CLTU that remains in the buffer.

4.1.5.4 Statistical information required for the generation of the status report shall be retained during the service instance provision period, regardless of a 'protocol abort' event.

4.1.5.5 Parameters that serve to relate notifications on an activity to operations that triggered that activity (such as `cltu-identification`) shall not be altered in the event of a 'protocol abort'.

4.1.6 ACCESS CONTROL

4.1.6.1 The initiator of an association shall present its own identity in the `initiator-identifier` parameter of the CLTU-BIND invocation.

4.1.6.2 If the CLTU-BIND operation is invoked with a value of `initiator-identifier` that is not known to the responder, the responder shall not make any attempt to authenticate that invocation. Instead, the responder shall generate a CLTU-BIND return with `result` set to 'negative result', `diagnostic` set to 'access denied', and `performer-credentials` set to 'unused'.

4.1.6.3 If the initiator is known to the responder, the responder shall attempt to authenticate the CLTU-BIND invocation (see 3.1.5) as required for the given initiator. If authentication succeeds, but the initiator is not authorized for the service instance indicated in the `service-instance-identifier` parameter of the CLTU-BIND invocation, the responder shall generate a CLTU-BIND return with `result` set to 'negative result' and `diagnostic` set to 'service instance not accessible to this initiator'.

NOTE – If authentication fails, the responder shall behave as specified in 4.1.7. If authentication is not required for the given initiator, it shall be as if authentication was successful.

4.1.6.4 If the initiator receives a CLTU-BIND return with a `responder-identifier` value that is not known to the initiator, the initiator shall not make any attempt to authenticate this return but shall abort the association by invoking CLTU-PEER-ABORT with `diagnostic` set to 'access denied'.

4.1.6.5 If the responder is known to the initiator, the initiator shall attempt to authenticate the CLTU-BIND return (see 3.1.5) as required for the given responder. If authentication succeeds, but the `responder-identifier` value is different from the expected responder identity, the initiator shall abort the association by invoking CLTU-PEER-ABORT with `diagnostic` set to 'unexpected responder ID'.

NOTE – If authentication fails, the initiator shall behave as specified in 4.1.7. If authentication is not required for the given responder, it shall be as if authentication was successful.

4.1.7 FAILING AUTHENTICATION

4.1.7.1 An incoming invocation or return shall be ignored if the `credentials` parameter cannot be authenticated when, by management arrangement, credentials are required.

4.1.7.2 If an invocation is ignored, the operation shall not be confirmed, and a report of the outcome shall not be returned to the provider.

4.1.7.3 If a return is ignored, it shall be as if no report of the outcome of the operation has been received.

4.2 FCLTU SERVICE PROVIDER BEHAVIOR

4.2.1 GENERAL REQUIREMENTS

4.2.1.1 The behavior of the FCLTU service provider shall conform to the state transition matrix specified in table 4-1.

4.2.1.2 All actions including state transitions specified for a given state and a given event shall be performed before a subsequent event is considered.

4.2.1.3 SLE-PDUs shall be sent in the sequence specified in table 4-1.

4.2.1.4 Implementations shall ensure that events are not lost while an earlier event is being processed but are buffered in first-in first-out order for processing as soon as processing of the earlier event has completed.

4.2.1.5 The state transition matrix specified in table 4-1 represents one instance of service and thus one association. Once the association is established, if an CLTU-BIND invocation for a different association but for the same service instance is received, it shall be rejected with an CLTU-BIND return with `result` set to ‘negative result’ and `diagnostic` set to ‘already bound’. This event shall not affect the association already in place.

4.2.2 STATE TABLE

NOTES

- 1 The state table specifies operation interactions and state transitions for the service provider.
- 2 The first column simply numbers the rows of the table.
- 3 The second column lists all incoming events. Where these events correspond to the arrival of an incoming SLE-PDU, the ASN.1 type defined for this SLE-PDU in annex A is indicated in parentheses, ().
- 4 Where an event is internal to the provider, its description is put in quotation marks, ‘ ’. These events are defined in table 4-2.
- 5 The three columns (one column per state) on the right side of the table specify the behavior the provider will exhibit, which depends on the current state and the incoming event. In some cases, the behavior in addition depends on Boolean conditions, also referred to as predicates. Such predicates are put in double quotation marks, “ ”. The predicates are defined in table 4-3. Predicates that are simple Boolean variables set only by the state machine itself, are referred to as Boolean flags and specified in table 4-4. The dependency on a predicate is presented in the form of an ‘IF <condition> THEN <action> [[ELSEIF <condition> THEN <action>] ELSE <action>] ENDIF’ clause.
- 6 If the action given in the table is simply to send a specific SLE-PDU, that is indicated by the appearance of the name of the ASN.1 type of the SLE-PDU to be sent in parentheses, (). If that SLE-PDU is a return, the name may be preceded by the plus symbol (+) to indicate that `result` is ‘positive result’, or by the negative symbol (-) to indicate that `result` is ‘negative result’. Where several actions are to be taken (referred to as a ‘compound action’), the name of the compound action is put in curly braces { }. The individual actions making up each compound action are identified in table 4-5.
- 7 ‘Not applicable’ is stated where the given event can only occur in the given state because of an implementation error on the provider side.

RECOMMENDED STANDARD FOR SLE FCLTU SERVICE

- 8 Where the consequences of an incoming event are not visible to the user because the provider does not send any SLE-PDU in reaction to the given event, the action is put in square brackets, [].
- 9 State transitions are indicated by an arrow and the number of the state that will be entered; for example, $\rightarrow 1$ indicates the transition to state 1.
- 10 Whenever the provider invokes a confirmed operation with `invoke-ID` set to `<n>`, it starts an associated return `<n>` timer. Should this timer expire before the return `<n>` is received, the provider shall invoke `CLTU-PEER-ABORT`.

Table 4-1: Provider Behavior

	Incoming Event	Unbound (State 1)	Ready (State 2)	Active (State 3)
1	(cltuBindInvocation)	IF "positive result" THEN (+cltuBindReturn) → 2 ELSE (-cltuBindReturn) ENDIF	{peer abort 'protocol error'} → 1	{peer abort 'protocol error'} → 1
2	'end of service instance provision period'	{clean up}	{peer abort 'end of service instance provision period'} → 1	{peer abort 'end of service instance provision period'} → 1
3	(cltuUnbindInvocation)	[ignore]	(cltuUnbindReturn) stop reporting-cycle timer IF "end" THEN {release resources} ENDIF	{peer abort 'protocol error'} → 1
4	(cltuStartInvocation)	[ignore]	IF "positive result" THEN (+cltuStartReturn) → 3 ELSE (-cltuStartReturn) ENDIF	{peer abort 'protocol error'} → 1
5	(cltuStopInvocation)	[ignore]	{peer abort 'protocol error'} → 1	IF "positive result" THEN {initiate stop} → 2 ELSE (-cltuStopReturn) ENDIF
6	(cltuTransferDataInvocation)	[ignore]	{peer abort 'protocol error'} → 1	IF "positive result" .AND. (.NOT. "service instance blocked") THEN buffer CLTU (+cltuTransferDataReturn) ELSE discard CLTU (-cltuTransferDataReturn) ENDIF
7	(cltuScheduleStatusReportInvocation)	[ignore]	IF "positive result" THEN (+cltuScheduleStatusReportReturn) IF "immediately" THEN {immediate report} ELSEIF "periodically" THEN {periodic report} ELSE stop reporting-cycle timer ENDIF ELSE (-cltuScheduleStatusReportReturn) ENDIF	IF "positive result" THEN (+cltuScheduleStatusReportReturn) IF "immediately" THEN {immediate report} ELSEIF "periodically" THEN {periodic report} ELSE stop reporting-cycle timer ENDIF ELSE (-cltuScheduleStatusReportReturn) ENDIF
8	'reporting-cycle timer expired'	Not applicable	{periodic report}	{periodic report}

	Incoming Event	Unbound (State 1)	Ready (State 2)	Active (State 3)
9	(cltuGetParameterInvocation)	[ignore]	IF "positive result" THEN (+cltuGetParameterReturn) ELSE (-cltuGetParameterReturn) ENDIF	IF "positive result" THEN (+cltuGetParameterReturn) ELSE (-cltuGetParameterReturn) ENDIF
10	(cltuThrowEventInvocation)	[ignore]	IF "positive result" THEN (+cltuThrowEventReturn) forward event to Complex Management ELSE (-cltuThrowEventReturn) ENDIF	IF "positive result" THEN (+cltuThrowEventReturn) forward event to Complex Management ELSE (-cltuThrowEventReturn) ENDIF
11	'cltu ready'	Not applicable	Not applicable	IF "notify production interrupted" THEN {notify 'production interrupted' and block} set "notify production interrupted" to FALSE ENDIF
12	'cltu radiated'	[ignore]	IF "report" THEN {notify 'cltu radiated'} ENDIF	IF "report" THEN {notify 'cltu radiated'} ENDIF
13	'sldu expired'	IF "continue" THEN clear CLTU buffer ENDIF	Not applicable	{notify 'sldu expired' and block}
14	'production interrupted'	IF "continue" THEN clear CLTU buffer ENDIF	IF .NOT. "deferred notification mode" THEN {notify 'production interrupted' and clear} set "notify production operational" to TRUE ENDIF	IF "deferred notification mode" THEN IF "processing cltu" THEN {notify 'production interrupted' and block} ELSE set "notify production interrupted" to TRUE ENDIF ELSE {notify 'production interrupted' and block} set "notify production operational" to TRUE ENDIF
15	'production halted'	IF "continue" THEN clear CLTU buffer ENDIF	{notify 'production halted' and clear} set "notify production operational" to TRUE	{notify 'production halted' and block} set "notify production operational" to TRUE
16	'production operational'	[ignore]	IF "notify production operational" THEN {notify 'production operational'} set "notify production operational" to FALSE ENDIF	IF "notify production operational" THEN {notify 'production operational'} set "notify production operational" to FALSE ENDIF
17	'buffer empty'	[ignore]	Not applicable	{notify 'buffer empty'}

	Incoming Event	Unbound (State 1)	Ready (State 2)	Active (State 3)
18	'action list completed'	Not applicable	{notify 'action list completed'}	{notify 'action list completed'}
19	'action list not completed'	Not applicable	{notify 'action list not completed'}	{notify 'action list not completed'}
20	'event condition evaluated to false'	Not applicable	{notify 'event condition evaluated to false'}	{notify 'event condition evaluated to false'}
21	(ctuPeerAbortInvocation)	[ignore]	{clean up} → 1	{clean up} → 1
22	'protocol abort'	[ignore]	{clean up} → 1	IF "continue" THEN stop reporting-cycle timer → 1 ELSE {clean up} → 1 ENDIF
23	'unsolicited invoke-ID'	[ignore]	{peer abort 'unsolicited invoke-ID'} → 1	{peer abort 'unsolicited invoke-ID'} → 1
24	'invalid SLE-PDU'	[ignore]	{peer abort 'encoding error'} → 1	{peer abort 'encoding error'} → 1
25	'unexpected SLE-PDU'	[ignore]	{peer abort 'protocol error'} → 1	{peer abort 'protocol error'} → 1
26	'not authenticated SLE-PDU'	[ignore]	[ignore]	[ignore]

Table 4-2: Event Description References

Event	Reference
'action list completed'	3.7.2.3
'action list not completed'	3.7.2.3
'buffer empty'	3.7.2.3
'cltu ready'	3.6.2.6, 3.6.2.7
'cltu radiated'	3.7.2.3
'end of service instance provision period'	3.12.2.2
'event condition evaluated to false'	3.7.2.3
'invalid SLE-PDU'	4.1.2
'not authenticated SLE-PDU'	4.1.7
'production halted'	3.7.2.3
'production interrupted'	3.7.2.3
'production operational'	3.7.2.3
'protocol abort'	4.1.5.3
'reporting-cycle timer expired'	3.8.2.6
'return-timeout-period timer <n> expired'	4.1.3
'sldu expired'	3.7.2.3
'unexpected SLE-PDU'	4.1.1
'unsolicited invoke-ID'	3.12.2.2

Table 4-3: Predicate Definitions

Predicate	Evaluates to TRUE if
"continue"	the <code>protocol-abort-mode</code> parameter value is 'continue'
"end"	all checks on the (<code>cltuUnbindInvocation</code>) PDU are passed and the <code>unbind-reason</code> parameter value is 'end'
"immediately"	all parameter checks on the (<code>cltuScheduleStatusReportInvocation</code>) PDU are passed and the <code>report-request-type</code> parameter value is 'immediately'
"periodically"	all parameter checks on the (<code>cltuScheduleStatusReportInvocation</code>) PDU are passed and the <code>report-request-type</code> parameter value is 'periodically'
"positive result"	all checks on the given invocation PDU are passed
"report"	the <code>report</code> parameter value in the associated (<code>cltuTransferDataInvocation</code>) PDU is 'produce report'

Table 4-4: Boolean Flags

Flag Name	Initial Value
“service instance blocked”	FALSE
“notify production operational”	FALSE
“notify production interrupted”	FALSE
“deferred notification mode”	FALSE
“processing cltu”	FALSE

Table 4-5: Compound Action Definitions

Name	Actions Performed
{clean up}	<ul style="list-style-type: none"> a) stop reporting-cycle timer b) reset reporting-cycle c) clear CLTU buffer d) set “service instance blocked” to FALSE
{immediate report}	<ul style="list-style-type: none"> a) (cltuStatusReportInvocation) b) stop reporting-cycle timer
{initiate stop}	<ul style="list-style-type: none"> a) clear CLTU buffer b) set “service instance blocked” to FALSE c) (+cltuStopReturn)
{notify ‘xxxx’}	(cltuAsyncNotifyInvocation) with notification-type set to ‘xxxx’; i.e., to the value corresponding to the incoming event
{notify ‘xxxx’ and clear}	<ul style="list-style-type: none"> a) (cltuAsyncNotifyInvocation) with notification-type set to ‘xxxx’; i.e., to the value corresponding to the incoming event b) clear CLTU buffer
{notify ‘xxxx’ and block}	<ul style="list-style-type: none"> a) (cltuAsyncNotifyInvocation) with notification-type set to ‘xxxx’; i.e., to the value corresponding to the incoming event b) set “service instance blocked” to TRUE c) clear CLTU buffer
{peer abort ‘xxxx’}	<ul style="list-style-type: none"> a) (cltuPeerAbortInvocation) with diagnostic set to ‘xxxx’ b) stop reporting-cycle timer c) reset reporting-cycle d) clear CLTU buffer e) set “service instance blocked” to FALSE
{periodic report}	<ul style="list-style-type: none"> a) (cltuStatusReportInvocation) b) set reporting-cycle timer to the reporting-cycle value in the most recent (cltuScheduleStatusReportInvocation) c) start reporting-cycle timer
{release resources}	<ul style="list-style-type: none"> a) delete the service instance b) release the associated resources c) if applicable, clear the CLTU buffer

ANNEX A**DATA TYPE DEFINITIONS****(NORMATIVE)****A1 INTRODUCTION**

A1.1 This annex defines the data types that are used by the FCLTU service. It is intended to provide a clear specification of these data types and to avoid ambiguity. It is not intended to constrain how these data types are implemented or encoded. These definitions are suitable for inclusion in any type of ASN.1 based protocol that implements the FCLTU service.

A1.2 The data type definitions are presented in seven ASN.1 modules.

A1.3 Subsection A2.1 contains basic data types that are common with other SLE transfer services. As additional services are specified by CCSDS, further data types may be added to this module or existing types may be extended. However, that eventuality is not expected to invalidate the module in its present form because it is expected that an implementation compliant with a future extended version of this module will be interoperable with an implementation based on its present version.

A1.4 Subsection A2.2 specifies the SLE-PDUs exchanged between an SLE user and an SLE provider application in order to establish, release, or abort an association. They are common among SLE transfer service types.

A1.5 Subsection A2.3 specifies SLE-PDUs related to invocations and returns that are common to SLE transfer service types.

A1.6 Subsection A2.4 specifies the format of the Service Instance Identifiers.

A1.7 Subsection A2.5 specifies data types specific to the FCLTU service. In part, these specific types are derived from types specified in A2.1 by means of subtyping.

A1.8 Subsection A2.6 specifies all incoming SLE-PDUs of the FCLTU service, as seen from a provider point of view. Where applicable, these SLE-PDUs are mapped to the generic SLE-PDUs defined in A2.2 and A2.3.

A1.9 Subsection A2.7 specifies in the same way all outgoing SLE-PDUs.

A1.10 Although A2.2, A2.3, A2.6 and A2.7 define the SLE-PDUs that will be exchanged between the SLE provider and user applications, they shall not be interpreted as requiring that these SLE-PDUs be completely mapped to the user data field of the underlying communications protocol. For example, depending on the communications protocol(s) used, part of the SLE-PDUs may be used to determine the appropriate setting of protocol control information.

A2 FCLTU DATA TYPE SPECIFICATION**A2.1 SLE TRANSFER SERVICE—COMMON TYPES**

CCSDS-SLE-TRANSFER-SERVICE-COMMON-TYPES

```
{ iso identified-organization(3)
  standards-producing-organization(112) ccsds(4)
  space-link-extension(3) sle-transfer-services(1)
  modules(1) common-modules(99) version-five(5) asn1-common-types(1)
}
```

DEFINITIONS

IMPLICIT TAGS

::= BEGIN

```
EXPORTS ConditionalTime
, Credentials
, DeliveryMode
, Diagnostics
, Duration
, ForwardDuStatus
, IntPosLong
, IntPosShort
, IntUnsignedLong
, IntUnsignedShort
, InvokeId
, ParameterName
, SlduStatusNotification
, SpaceLinkDataUnit
, Time
;
```

```
ConditionalTime ::= CHOICE
{ undefined [0] NULL
, known [1] Time
}
```

```
-- If credentials are used, it will be necessary that
-- the internal structure of the octet string is known
-- to both parties. Since the structure will depend on
-- algorithm used, it is not specified here. However,
-- the peer entities may use ASN.1 encoding to make the
-- internal structure visible.
```

```
Credentials ::= CHOICE
{ unused [0] NULL
, used [1] OCTET STRING (SIZE (8 .. 256))
}
```

```
DeliveryMode ::= INTEGER
{ rtnTimelyOnline (0)
, rtnCompleteOnline (1)
, rtnOffline (2)
, fwdOnline (3)
, fwdOffline (4)
}
```

RECOMMENDED STANDARD FOR SLE FCLTU SERVICE

```

Diagnostics                ::=  INTEGER
{ duplicateInvokeId        (100)
, otherReason              (127)
}

-- The Duration is expressed in microseconds
Duration                   ::=  IntUnsignedLong

ForwardDuStatus            ::=  INTEGER
{ radiated                 (0)
, expired                  (1)
, interrupted              (2)
, acknowledged            (3)  -- FSP
, productionStarted       (4)  -- CLTU: 'radiation started'
, productionNotStarted    (5)  -- CLTU: 'radiation not started'
, unsupportedTransmissionMode (6) -- FSP
}

-- 1 to (2^32)-1
IntPosLong                 ::=  INTEGER (1 .. 4294967295)

-- 1 to (2^16)-1
IntPosShort                ::=  INTEGER (1 .. 65535)

-- 0 to (2^32)-1
IntUnsignedLong            ::=  INTEGER (0 .. 4294967295)

-- 0 to (2^16)-1
IntUnsignedShort           ::=  INTEGER (0 .. 65535)

InvokeId                   ::=  IntUnsignedShort

```

RECOMMENDED STANDARD FOR SLE FCLTU SERVICE

```

ParameterName ::= INTEGER
{
  acquisitionSequenceLength (201)
,  apidList (2)
,  bitLockRequired (3)
,  blockingTimeoutPeriod (0)
,  blockingUsage (1)
,  bufferSize (4)
,  clcwGlobalVcId (202)
,  clcwPhysicalChannel (203)
,  copCntrFramesRepetition (300)
,  deliveryMode (6)
,  directiveInvocation (7)
,  directiveInvocationOnline (108)
,  expectedDirectiveIdentification (8)
,  expectedEventInvocationIdentification (9)
,  expectedSlduIdentification (10)
,  fopSlidingWindow (11)
,  fopState (12)
,  latencyLimit (15)
,  mapList (16)
,  mapMuxControl (17)
,  mapMuxScheme (18)
,  maximumFrameLength (19)
,  maximumPacketLength (20)
,  maximumSlduLength (21)
,  minimumDelayTime (204)
,  minReportingCycle (301)
,  modulationFrequency (22)
,  modulationIndex (23)
,  notificationMode (205)
,  permittedControlWordTypeSet (101)
,  permittedFrameQuality (302)
,  permittedGvcidSet (24)
,  permittedTcVcidSet (102)
,  permittedTransmissionMode (107)
,  permittedUpdateModeSet (103)
,  ploplIdleSequenceLength (206)
,  ploplInEffect (25)
,  protocolAbortMode (207)
,  reportingCycle (26)
,  requestedControlWordType (104)
,  requestedFrameQuality (27)
,  requestedGvcid (28)
,  requestedTcVcid (105)
,  requestedUpdateMode (106)
,  returnTimeoutPeriod (29)
,  rfAvailable (30)
,  rfAvailableRequired (31)
,  segmentHeader (32)
,  sequCntrFramesRepetition (303)
,  subcarrierToBitRateRatio (34)
,  throwEventOperation (304)
,  timeoutType (35)
,  timerInitial (36)
,  transmissionLimit (37)
,  transmitterFrameSequenceNumber (38)
,  vcMuxControl (39)
,  vcMuxScheme (40)
,  virtualChannel (41)
}

```

RECOMMENDED STANDARD FOR SLE FCLTU SERVICE

```
SlduStatusNotification ::= INTEGER
{ produceNotification      (0)
, doNotProduceNotification (1)
}

SpaceLinkDataUnit ::= OCTET STRING (SIZE (1 .. 65536))

Time ::= CHOICE
{ ccsdsFormat      [0] TimeCCSDS
, ccsdsPicoFormat [1] TimeCCSDSpico
}

TimeCCSDS ::= OCTET STRING (SIZE(8))
-- P-field is implicit (not present, defaulted to 41 hex
-- T-field:
-- 2 octets: number of days since 1958/01/01 00:00:00
-- 4 octets: number of milliseconds of the day
-- 2 octets: number of microseconds of the millisecond
-- (set to 0 if not used)
-- This definition reflects exactly the format of the CCSDS defined
-- time tag as used in spacelink data units (see reference [5]).

TimeCCSDSpico ::= OCTET STRING (SIZE(10))
-- P-field is implicit (not present, defaulted to 42 hex
-- T-field:
-- 2 octets: number of days since 1958/01/01 00:00:00
-- 4 octets: number of milliseconds of the day
-- 4 octets: number of picoseconds of the millisecond
-- (set to 0 if not used)
-- This definition reflects exactly the format of the CCSDS defined
-- time tag as used in spacelink data units (see reference [5]).

END
```

A2.2 SLE-TRANSFER SERVICE—BIND TYPES

CCSDS-SLE-TRANSFER-SERVICE-BIND-TYPES

```
{ iso identified-organization(3)
  standards-producing-organization(112) ccsds(4)
  space-link-extension(3) sle-transfer-services(1)
  modules(1) common-modules(99) version-four(4) asn1-bind-types(2)
}
```

DEFINITIONS

IMPLICIT TAGS

::= BEGIN

```
EXPORTS SleBindInvocation
, SleBindReturn
, SlePeerAbort
, SleUnbindInvocation
, SleUnbindReturn
;
```

```
IMPORTS Credentials
, IntPosShort
FROM CCSDS-SLE-TRANSFER-SERVICE-COMMON-TYPES
```

```
ServiceInstanceIdentifier
FROM CCSDS-SLE-TRANSFER-SERVICE-SERVICE-INSTANCE-ID
```

;

```
-- =====
-- The first part of the module definition contains the SLE-PDUs
-- =====
```

```
SleBindInvocation ::= SEQUENCE
{ invokerCredentials Credentials
, initiatorIdentifier AuthorityIdentifier
, responderPortIdentifier PortId
, serviceType ApplicationIdentifier
, versionNumber VersionNumber
, serviceInstanceIdentifier ServiceInstanceIdentifier
}
```

```
SleBindReturn ::= SEQUENCE
{ performerCredentials Credentials
, responderIdentifier AuthorityIdentifier
, result CHOICE
{ positive [0] VersionNumber
, negative [1] BindDiagnostic
}
}
```

```
SlePeerAbort ::= PeerAbortDiagnostic
```

```
SleUnbindInvocation ::= SEQUENCE
{ invokerCredentials Credentials
, unbindReason UnbindReason
}
```

RECOMMENDED STANDARD FOR SLE FCLTU SERVICE

```

SleUnbindReturn      ::= SEQUENCE
{
  responderCredentials  Credentials
, result               CHOICE
  { positive           [0]  NULL
  }
}

-- =====
-- The second part of the module definition contains the types
-- used by the SLE-PDUs declared in the first part.
-- =====

ApplicationIdentifier ::= INTEGER
{
  rtnAllFrames          (0)
, rtnInsert             (1)
, rtnChFrames          (2)
-- rtnChFrames includes rtnMcFrames and rtnVcFrames
, rtnChFsh             (3)
-- rtnChFsh includes rtnMcFsh and rtnVcFsh
, rtnChOcf             (4)
-- rtnChOcf includes rtnMcOcf and rtnVcOcf
, rtnBitstr            (5)  -- AOS
, rtnSpacePkt          (6)
, fwdAosSpacePkt       (7)
, fwdAosVca            (8)
, fwdBitstr            (9)
, fwdProtoVcdu         (10)
, fwdInsert            (11)
, fwdCVcdu             (12)
, fwdTcSpacePkt        (13)  -- conventional telecommand
, fwdTcVca             (14)  -- conventional telecommand
, fwdTcFrame           (15)
, fwdCltu              (16)
}

AuthorityIdentifier  ::= IdentifierString (SIZE (3 .. 16))

BindDiagnostic       ::= INTEGER
{
  accessDenied         (0)
, serviceTypeNotSupported (1)
, versionNotSupported  (2)
, noSuchServiceInstance (3)
, alreadyBound         (4)
, siNotAccessibleToThisInitiator (5)
, inconsistentServiceType (6)
, invalidTime          (7)
, outOfService         (8)
, otherReason          (127)
}

IdentifierString     ::= VisibleString (FROM (ALL EXCEPT " "))

LogicalPortName      ::= IdentifierString (SIZE (1 .. 128))

```

RECOMMENDED STANDARD FOR SLE FCLTU SERVICE

```
PeerAbortDiagnostic      ::=  INTEGER
{  accessDenied          (0)
,  unexpectedResponderId (1)
,  operationalRequirement (2)
,  protocolError         (3)
,  communicationsFailure (4)
,  encodingError         (5)
,  returnTimeout         (6)
,  endOfServiceProvisionPeriod (7)
,  unsolicitedInvokeId   (8)
,  otherReason           (127)
-- The range of this INTEGER shall be (0 .. 255).
-- (128 .. 255) is reserved for diagnostic codes
-- that are specific to the communications technology used.
}

PortId                   ::=  LogicalPortName

UnbindReason             ::=  INTEGER
{  end                   (0)
,  suspend               (1)
,  versionNotSupported  (2)
,  other                 (127)
}

VersionNumber            ::=  IntPosShort

END
```

A2.3 SLE TRANSFER SERVICE—COMMON PDUS

CCSDS-SLE-TRANSFER-SERVICE-COMMON-PDUS

```
{ iso identified-organization(3)
  standards-producing-organization(112) ccsds(4)
  space-link-extension(3) sle-transfer-services(1)
  modules(1) common-modules(99) version-four(4) asn1-common-pdu(3)
}
```

DEFINITIONS

IMPLICIT TAGS

::= BEGIN

```
EXPORTS ReportingCycle
, SleAcknowledgement
, SleScheduleStatusReportInvocation
, SleScheduleStatusReportReturn
, SleStopInvocation
;
```

```
IMPORTS Credentials
, Diagnostics
, InvokeId
FROM CCSDS-SLE-TRANSFER-SERVICE-COMMON-TYPES
;
```

```
-- =====
-- The first part of the module definition contains the SLE-PDUs
-- =====
```

```
SleAcknowledgement ::= SEQUENCE
{ credentials Credentials
, invokeId InvokeId
, result CHOICE
{ positiveResult [0] NULL
, negativeResult [1] Diagnostics
}
}
```

```
SleScheduleStatusReportInvocation ::= SEQUENCE
{ invokerCredentials Credentials
, invokeId InvokeId
, reportRequestType ReportRequestType
}
```

```
SleScheduleStatusReportReturn ::= SEQUENCE
{ performerCredentials Credentials
, invokeId InvokeId
, result CHOICE
{ positiveResult [0] NULL
, negativeResult [1] DiagnosticScheduleStatusReport
}
}
```

RECOMMENDED STANDARD FOR SLE FCLTU SERVICE

```
SleStopInvocation ::= SEQUENCE
{
  invokerCredentials Credentials
,  invokeId           InvokeId
}

-- =====
-- The second part of the module definition contains the types
-- used by the SLE-PDUs declared in the first part.
-- =====

DiagnosticScheduleStatusReport ::= CHOICE
{
  common          [0] Diagnostics
,  specific       [1] INTEGER
  {
    notSupportedInThisDeliveryMode (0) -- not used for
                                     -- version 1 forward transfer
                                     -- services
    ,  alreadyStopped (1)
    ,  invalidReportingCycle (2)
  }
}

-- The cycle duration is expressed in seconds
ReportingCycle ::= INTEGER (2 .. 600)

ReportRequestType ::= CHOICE
{
  immediately [0] NULL
,  periodically [1] ReportingCycle
,  stop [2] NULL
}

END
```

A2.4 SLE TRANSFER SERVICE—SERVICE-INSTANCE-ID

```

CCSDS-SLE-TRANSFER-SERVICE-SERVICE-INSTANCE-ID

{ iso identified-organization(3) standards-producing-organization(112)
  ccsds(4) space-link-extension(3) sle-transfer-services(1)
  modules(1) common-modules(99) version-five(5)
  asnl-service-id-type(4)
}

DEFINITIONS
IMPLICIT TAGS
 ::= BEGIN

EXPORTS ServiceInstanceIdentifier
;

-- Object Identifiers definition
sagr      OBJECT IDENTIFIER ::= {iso 3 112 4 3 1 2 52}
spack     OBJECT IDENTIFIER ::= {iso 3 112 4 3 1 2 53}
fsl-fg    OBJECT IDENTIFIER ::= {iso 3 112 4 3 1 2 14}
rsl-fg    OBJECT IDENTIFIER ::= {iso 3 112 4 3 1 2 38}
cltu      OBJECT IDENTIFIER ::= {iso 3 112 4 3 1 2 7}
fsp       OBJECT IDENTIFIER ::= {iso 3 112 4 3 1 2 10}
raf       OBJECT IDENTIFIER ::= {iso 3 112 4 3 1 2 22}
rcf       OBJECT IDENTIFIER ::= {iso 3 112 4 3 1 2 46}
rcfsh     OBJECT IDENTIFIER ::= {iso 3 112 4 3 1 2 44}
rocf      OBJECT IDENTIFIER ::= {iso 3 112 4 3 1 2 49}
rsp       OBJECT IDENTIFIER ::= {iso 3 112 4 3 1 2 40}
tcf       OBJECT IDENTIFIER ::= {iso 3 112 4 3 1 2 12}
tcva      OBJECT IDENTIFIER ::= {iso 3 112 4 3 1 2 16}

```

RECOMMENDED STANDARD FOR SLE FCLTU SERVICE

```
-- ++++++
-- ++++++
-- The Service Instance Identifier is a concatenation of Attributes.
-- Each Attribute is composed of a name and a value.
-- Note that the Attribute names are not specified by the ASN.1 proper,
-- but by means of comments in this module.
-- The following Attributes identify the Service Instance:
-- Service agreement
--   the name of which is:  "sagr",
--   the value of which is to be agreed between the user and the
--   provider;
-- Service package
--   the name of which is:  "spack",
--   the value of which is to be agreed between the user and the
--   provider;
-- Forward/Return Service Functional Group
--   the name of which is:
--     "fsl-fg" for the forward services,
--   or:
--     "rsl-fg" for the return services,
--   the value of which is to be agreed between the user and the
--   provider;
-- Service Name identifier,
--   the name of which is:  "cltu"
--   the value of which is:  "cltu" plus an instance number;
--   or:
--     the name of which is:  "fsp",
--     the value of which is:  "fsp" plus an instance number;
--   or:
--     the name of which is:  "tcva",
--     the value of which is:  "tcva" plus an instance number;
--   or:
--     the name of which is:  "tcf",
--     the value of which is:  "tcf" plus an instance number;
--   or:
--     the name of which is:  "raf",
--     the value of which is:  "onlc" or "onlt" or "offl" plus an
--     instance number;
--   or:
--     the name of which is:  "rcf",
--     the value of which is:  "onlc" or "onlt" or "offl" plus an
--     instance number;
--   or:
--     the name of which is:  "rocf",
--     the value of which is:  "onlc" or "onlt" or "offl" plus an
--     instance number;
--   or:
--     the name of which is:  "rcfsh",
--     the value of which is:  "onlc" or "onlt" or "offl" plus an
--     instance number;
--   or:
--     the name of which is:  "rsp",
--     the value of which is:  "onlc" or "onlt" or "offl" plus an
--     instance number.
--
-- To obtain the string corresponding to the instance identifier, one must
-- concatenate the Attributes values and Names as follows:
-- 'Attribute Name'='Attribute value'.
-- Two Attributes must be separated by a ".".
```

RECOMMENDED STANDARD FOR SLE FCLTU SERVICE

-- Example: 'sagr=xyz.spack=abcdef.rsl-fg=gfjdy.raf=onlc2'
-- Note that the quotes are not part of the string.

```
ATTRIBUTE ::= CLASS
{ &id OBJECT IDENTIFIER UNIQUE
}
WITH SYNTAX { ID &id }

GeneralAttributes ATTRIBUTE ::=
{ serviceAgreement
| servicePackage
| forwardService
| returnService
}

ServiceInstanceAttribute ::= SET SIZE(1) OF SEQUENCE
{ identifier ATTRIBUTE.&id
({ServiceInstanceAttributes})
, siAttributeValue VisibleString (SIZE (1 .. 256))
}

ServiceInstanceAttributes ATTRIBUTE ::=
{ GeneralAttributes
| ServiceNames
}

ServiceInstanceIdentifier ::= SEQUENCE OF ServiceInstanceAttribute

ServiceNames ATTRIBUTE ::=
{ rafService
| rcfService
| rcfshService
| rocfService
| rspService
| cltuService
| fspService
| tcfService
| tcvaService
}

-- ++++++
-- CLTU Service Definition
-- The cltu Service Id starts with "cltu" and is
-- followed by the instance number.
cltuService ATTRIBUTE ::= { ID cltu }

-- ++++++
-- Forward Service Definition
forwardService ATTRIBUTE ::= { ID fsl-fg }

-- ++++++
-- FSP Service Definition
-- The fsp Service Id starts with "fsp" and is
-- followed by the instance number.
fspService ATTRIBUTE ::= { ID fsp }
```

RECOMMENDED STANDARD FOR SLE FCLTU SERVICE

```
-- ++++++
-- RAF Service Definition
-- The raf Service Id starts with "onlc" or "onlt" or "offl" and is
-- followed by the instance number.
rafService ATTRIBUTE ::= { ID raf }

-- ++++++
-- RCF Service Definition
-- The rcf Service Id starts with "onlc" or "onlt" or "offl" and is
-- followed by the instance number.
rcfService ATTRIBUTE ::= { ID rcf }

-- ++++++
-- RCFSH Service Definition
-- The rcfsh Service Id starts with "onlc" or "onlt" or "offl" and is
-- followed by the instance number.
rcfshService ATTRIBUTE ::= { ID rcfsh }

-- ++++++
-- Return Service Definition
returnService ATTRIBUTE ::= { ID rsl-fg }

-- ++++++
-- ROCF Service Definition
-- The rocf Service Id starts with "onlc" or "onlt" or "offl" and is
-- followed by the instance number.
rocfService ATTRIBUTE ::= { ID rocf }

-- ++++++
-- RSP Service Definition
-- The rocf Service Id starts with "onlc" or "onlt" or "offl" and is
-- followed by the instance number.
rspService ATTRIBUTE ::= { ID rsp }

-- ++++++
-- Service Agreement Definition
serviceAgreement ATTRIBUTE ::= { ID sagr }

-- ++++++
-- Service Package Definition
servicePackage ATTRIBUTE ::= { ID spack }

-- ++++++
-- TCF Service Definition
-- The tcf Service Id starts with "tcf" and is
-- followed by the instance number.
tcfService ATTRIBUTE ::= { ID tcf }

-- ++++++
-- TCVA Service Definition
-- The tcva Service Id starts with "tcva" and is
-- followed by the instance number.
tcvaService ATTRIBUTE ::= { ID tcva }

END
```

A2.5 SLE TRANSFER SERVICE—FCLTU STRUCTURES

CCSDS-SLE-TRANSFER-SERVICE-CLTU-STRUCTURES

```
{ iso identified-organization(3) standards-producing-organization(112)
  ccsds(4) space-link-extension(3) sle-transfer-services(1)
  modules(1) forward-cltu-service(21) version-six(6)
  asn1-transfer-structures(1)
}
```

DEFINITIONS

IMPLICIT TAGS

::= BEGIN

```
EXPORTS      BufferSize
,            CltuData
,            CltuGetParameter
,            CltuIdentification
,            CltuLastProcessed
,            CltuLastOk
,            CltuNotification
,            CltuParameterName
,            CltuStatus
,            DiagnosticCltuGetParameter
,            DiagnosticCltuStart
,            DiagnosticCltuThrowEvent
,            DiagnosticCltuTransferData
,            EventInvocationId
,            NumberOfCltusProcessed
,            NumberOfCltusRadiated
,            NumberOfCltusReceived
,            ProductionStatus
,            UplinkStatus
;

IMPORTS      ConditionalTime
,            DeliveryMode
,            Diagnostics
,            Duration
,            ForwardDuStatus
,            IntPosLong
,            IntPosShort
,            IntUnsignedLong
,            IntUnsignedShort
,            ParameterName
,            SpaceLinkDataUnit
,            Time
FROM CCSDS-SLE-TRANSFER-SERVICE-COMMON-TYPES
  ReportingCycle
FROM CCSDS-SLE-TRANSFER-SERVICE-COMMON-PDUS
;

```

-- Available buffer in octets

BufferSize ::= IntUnsignedLong

RECOMMENDED STANDARD FOR SLE FCLTU SERVICE

```
ClcwGvcId ::= CHOICE
{
  configured [0] GvcId
,
  notConfigured [1] NULL
}

ClcwPhysicalChannel ::= CHOICE
{
  configured [0] VisibleString (SIZE (1..32))
,
  notConfigured [1] NULL
}

CltuData ::= SpaceLinkDataUnit

CltuDeliveryMode ::= DeliveryMode
(
  fwdOnline
)
```

RECOMMENDED STANDARD FOR SLE FCLTU SERVICE

```

CltuGetParameter ::= CHOICE
{
  parAcquisitionSequenceLength [0] SEQUENCE
  {
    parameterName      ParameterName
                       (acquisitionSequenceLength)
    , parameterValue   IntUnsignedShort
  }
  , parBitLockRequired [1] SEQUENCE
  {
    parameterName      ParameterName (bitLockRequired)
    , parameterValue   INTEGER
    {
      yes              (0)
      , no              (1)
    }
  }
  , parClcwGlobalVcId [2] SEQUENCE
  {
    parameterName      ParameterName (clcwGlobalVcId)
    , parameterValue   ClcwGvcId
  }
  , parClcwPhysicalChannel [3] SEQUENCE
  {
    parameterName      ParameterName
                       (clcwPhysicalChannel)
    , parameterValue   ClcwPhysicalChannel
  }
  , parDeliveryMode [4] SEQUENCE
  {
    parameterName      ParameterName (deliveryMode)
    , parameterValue   CltuDeliveryMode
  }
  , parCltuIdentification [5] SEQUENCE
  {
    parameterName      ParameterName
                       (expectedSlduIdentification)
    , parameterValue   CltuIdentification
  }
  , parEventInvocationIdentification [6] SEQUENCE
  {
    parameterName      ParameterName
                       (expectedEventInvocationIdentification)
    , parameterValue   EventInvocationId
  }
  , parMaximumCltuLength [7] SEQUENCE
  {
    parameterName      ParameterName (maximumSlduLength)
    , parameterValue   INTEGER (12 .. 4096)
  }
  , parMinimumDelayTime [8] SEQUENCE
  {
    parameterName      ParameterName (minimumDelayTime)
    , parameterValue   Duration
  }
  , parMinReportingCycle [19] SEQUENCE
  {
    parameterName      ParameterName (minReportingCycle)
    , parameterValue   IntPosShort (1 .. 600)
  }
  , parModulationFrequency [9] SEQUENCE
  {
    parameterName      ParameterName (modulationFrequency)
    , parameterValue   ModulationFrequency
  }
  , parModulationIndex [10] SEQUENCE
  {
    parameterName      ParameterName (modulationIndex)
    , parameterValue   ModulationIndex
  }
  , parNotificationMode [11] SEQUENCE
  {
    parameterName      ParameterName (notificationMode)
    , parameterValue   INTEGER
    {
      deferred         (0)
    }
  }
}

```

RECOMMENDED STANDARD FOR SLE FCLTU SERVICE

```

        , immediate                (1)
    }
}
, parPlop1IdleSequenceLength      [12] SEQUENCE
  { parameterName                 ParameterName
    , parameterValue              (plop1IdleSequenceLength)
    , parameterValue              IntUnsignedShort
  }
, parPlopInEffect                 [13] SEQUENCE
  { parameterName                 ParameterName (plopInEffect)
    , parameterValue              INTEGER
    { plop1                       (0)
      , plop2                     (1)
    }
  }
, parProtocolAbortMode           [14] SEQUENCE
  { parameterName                 ParameterName (protocolAbortMode)
    , parameterValue              INTEGER
    { abort                       (0)
      , continue                  (1)
    }
  }
, parReportingCycle              [15] SEQUENCE
  { parameterName                 ParameterName (reportingCycle)
    , parameterValue              CurrentReportingCycle
  }
, parReturnTimeout               [16] SEQUENCE
  { parameterName                 ParameterName (returnTimeoutPeriod)
    , parameterValue              TimeoutPeriod
  }
, parRfAvailableRequired         [17] SEQUENCE
  { parameterName                 ParameterName
    , parameterValue              (rfAvailableRequired)
    , parameterValue              INTEGER
    { yes                         (0)
      , no                        (1)
    }
  }
, parSubcarrierToBitRateRatio    [18] SEQUENCE
  { parameterName                 ParameterName
    , parameterValue              (subcarrierToBitRateRatio)
    , parameterValue              SubcarrierDivisor
  }
}

CltuIdentification ::= IntUnsignedLong

CltuLastOk ::= CHOICE
{ noCltuOk
, cltuOk
  { cltuIdentification
  , radiationStopTime
  }
}

```

RECOMMENDED STANDARD FOR SLE FCLTU SERVICE

```

CltuLastProcessed ::= CHOICE
{
  noCltuProcessed [0] NULL
  , cltuProcessed [1] SEQUENCE
  {
    cltuIdentification CltuIdentification
    , radiationStartTime ConditionalTime
    , cltuStatus CltuStatus
  }
}

CltuNotification ::= CHOICE
{
  cltuRadiated [0] NULL
  , slduExpired [1] NULL
  , productionInterrupted [2] NULL
  , productionHalted [3] NULL
  , productionOperational [4] NULL
  , bufferEmpty [5] NULL
  , actionListCompleted [6] EventInvocationId
  , actionListNotCompleted [7] EventInvocationId
  , eventConditionEvFalse [8] EventInvocationId
}

CltuParameterName ::= ParameterName
(
  acquisitionSequenceLength
  | bitLockRequired
  | clcwGlobalVcId
  | clcwPhysicalChannel
  | deliveryMode
  | expectedSlduIdentification
  | expectedEventInvocationIdentification
  | maximumSlduLength
  | minimumDelayTime
  | minReportingCycle
  | modulationFrequency
  | modulationIndex
  | notificationMode
  | plop1IdleSequenceLength
  | plopInEffect
  | protocolAbortMode
  | reportingCycle
  | returnTimeoutPeriod
  | rfAvailableRequired
  | subcarrierToBitRateRatio
)

CltuStatus ::= ForwardDuStatus
(
  radiated
  | expired
  | interrupted
  | productionStarted -- radiation started
  | productionNotStarted -- radiation not started
)

CurrentReportingCycle ::= CHOICE
{
  periodicReportingOff [0] NULL
  , periodicReportingOn [1] ReportingCycle
}

```

RECOMMENDED STANDARD FOR SLE FCLTU SERVICE

```

DiagnosticCltuGetParameter      ::= CHOICE
{
  common                        [0]   Diagnostics
,
  specific                      [1]   INTEGER
  {
    unknownParameter           (0)
  }
}

DiagnosticCltuStart            ::= CHOICE
{
  common                        [0]   Diagnostics
,
  specific                      [1]   INTEGER
  {
    outOfService               (0)
  ,
    unableToComply              (1)
  ,
    productionTimeExpired       (2)
  ,
    invalidCltuId               (3)
  }
}

DiagnosticCltuThrowEvent       ::= CHOICE
{
  common                        [0]   Diagnostics
,
  specific                      [1]   INTEGER
  {
    operationNotSupported       (0)
  ,
    eventInvocIdOutOfSequence   (1)
  ,
    noSuchEvent                 (2)
  }
}

DiagnosticCltuTransferData     ::= CHOICE
{
  common                        [0]   Diagnostics
,
  specific                      [1]   INTEGER
  {
    unableToProcess             (0)
  ,
    unableToStore               (1)
  ,
    outOfSequence               (2)
  ,
    inconsistentTimeRange       (3)
  ,
    invalidTime                 (4)
  ,
    lateSldu                    (5)
  ,
    invalidDelayTime            (6)
  ,
    cltuError                   (7)
  }
}

EventInvocationId              ::= IntUnsignedLong

GvcId                          ::= SEQUENCE
{
  spacecraftId                 INTEGER (0 .. 65535)
-- Value range for TM Transfer Frames: (0 .. 255)
-- Value range for AOS Transfer Frames: (0 .. 255)
-- Value range for USLP Transfer Frames: (0 .. 65535)
,
  versionNumber                INTEGER (0 | 1 | 12)
-- Value for TM (Version 1) Transfer Frames: 0 ('00'B)
-- Value for AOS (Version 2) Transfer Frames: 1 ('01'B)
-- Value for USLP (Version 4) Transfer Frames: 12 ('1100'B)
,
  vcId                         CHOICE
  {
    masterChannel               [0]   NULL
  ,
    virtualChannel              [1]   VcId
  }
}

```

RECOMMENDED STANDARD FOR SLE FCLTU SERVICE

```
-- Either the subcarrier frequency, or,
-- in case of direct modulation, the bit rate, measured in 1/10 Hz
ModulationFrequency          ::=  IntPosLong

-- peak modulation index angle expressed in 1/1000 radians
ModulationIndex              ::=  IntPosShort

NumberOfCltusProcessed       ::=  IntUnsignedLong

NumberOfCltusRadiated        ::=  IntUnsignedLong

NumberOfCltusReceived        ::=  IntUnsignedLong

ProductionStatus             ::=  INTEGER
{ operational                 (0)
, configured                  (1)
, interrupted                 (2)
, halted                      (3)
}

-- Divisor of the subcarrier frequency
-- If direct carrier modulation, the value is 1
SubcarrierDivisor            ::=  IntPosShort

-- measured in seconds
TimeoutPeriod                 ::=  INTEGER (1 .. 600)

UplinkStatus                  ::=  INTEGER
{ uplinkStatusNotAvailable    (0)
, noRfAvailable               (1)
, noBitLock                   (2)
, nominal                     (3)
}

VcId                          ::=  INTEGER (0 .. 63)
-- The actual permissible range depends on the TFVN being part of the
-- GVCID.
-- In case of TM the permissible range is 0 to 7 (3 bits).
-- In case of AOS the permissible range is 0 to 63 (6 bits).
-- In case of USLP the permissible range is 0 to 63 (6 bits).
-- In case of TC the permissible range is 0 to 63 (6 bits).

END
```

A2.6 SLE TRANSFER SERVICE—FCLTU INCOMING PDUS

CCSDS-SLE-TRANSFER-SERVICE-CLTU-INCOMING-PDUS

```
{ iso identified-organization(3) standards-producing-organization(112)
  ccstds(4) space-link-extension(3) sle-transfer-services(1)
  modules(1) forward-cltu-service(21) version-four(4)
  asnl-incoming-pdus(2)
}
```

DEFINITIONS

IMPLICIT TAGS

::= BEGIN

```
IMPORTS      ConditionalTime
,           Credentials
,           Duration
,           IntPosShort
,           InvokeId
,           SlduStatusNotification
FROM CCSDS-SLE-TRANSFER-SERVICE-COMMON-TYPES
           SleScheduleStatusReportInvocation
,           SleStopInvocation
FROM CCSDS-SLE-TRANSFER-SERVICE-COMMON-PDUS
           CltuData
,           CltuIdentification
,           CltuParameterName
,           EventInvocationId
FROM CCSDS-SLE-TRANSFER-SERVICE-CLTU-STRUCTURES
           SleBindInvocation
,           SlePeerAbort
,           SleUnbindInvocation
FROM CCSDS-SLE-TRANSFER-SERVICE-BIND-TYPES
;
```

```
-- =====
-- The first part of the module definition contains the CLTU type
-- that contains all the possible PDUs the provider may receive.
-- =====
```

```
CltuUserToProviderPdu      ::= CHOICE

{ cltuBindInvocation          [100]    SleBindInvocation
, cltuUnbindInvocation        [102]    SleUnbindInvocation
, cltuStartInvocation         [0]      CltuStartInvocation
, cltuStopInvocation          [2]      SleStopInvocation
, cltuScheduleStatusReportInvocation [4]
                                SleScheduleStatusReportInvocation
, cltuGetParameterInvocation  [6]      CltuGetParameterInvocation
, cltuThrowEventInvocation    [8]      CltuThrowEventInvocation
, cltuTransferDataInvocation  [10]     CltuTransferDataInvocation
, cltuPeerAbortInvocation     [104]    SlePeerAbort
}
```

RECOMMENDED STANDARD FOR SLE FCLTU SERVICE

```
-- =====
-- The second part of the module definition contains the types
-- used by the CLTU-PDUs declared in the first part.
-- =====

CltuGetParameterInvocation ::= SEQUENCE
{
  invokerCredentials      Credentials
,  invokeId                InvokeId
,  cltuParameter          CltuParameterName
}

CltuStartInvocation ::= SEQUENCE
{
  invokerCredentials      Credentials
,  invokeId                InvokeId
,  firstCltuIdentification CltuIdentification
}

CltuThrowEventInvocation ::= SEQUENCE
{
  invokerCredentials      Credentials
,  invokeId                InvokeId
,  eventInvocationIdentification EventInvocationId
,  eventIdentifier        IntPosShort
,  eventQualifier         OCTET STRING (SIZE (1 .. 1024))
}

CltuTransferDataInvocation ::= SEQUENCE
{
  invokerCredentials      Credentials
,  invokeId                InvokeId
,  cltuIdentification     CltuIdentification
,  earliestTransmissionTime ConditionalTime
,  latestTransmissionTime ConditionalTime
,  delayTime              Duration
,  slduRadiationNotification SlduStatusNotification
,  cltuData                CltuData
}

END
```

A2.7 SLE TRANSFER SERVICE—FCLTU OUTGOING PDUS

CCSDS-SLE-TRANSFER-SERVICE-CLTU-OUTGOING-PDUS

```
{ iso identified-organization(3) standards-producing-organization(112)
  ccsds(4) space-link-extension(3) sle-transfer-services(1)
  modules(1) forward-cltu-service(21) version-four(4)
  asnl-outgoing-pdus(3)
}
```

DEFINITIONS

IMPLICIT TAGS

::= BEGIN

```
IMPORTS
    ConditionalTime
    ,
    Credentials
    ,
    InvokeId
    ,
    Time
FROM CCSDS-SLE-TRANSFER-SERVICE-COMMON-TYPES
    SleAcknowledgement
    ,
    SleScheduleStatusReportReturn
FROM CCSDS-SLE-TRANSFER-SERVICE-COMMON-PDUS
    SleBindReturn
    ,
    SleUnbindReturn
    ,
    SlePeerAbort
FROM CCSDS-SLE-TRANSFER-SERVICE-BIND-TYPES
    BufferSize
    ,
    CltuGetParameter
    ,
    CltuIdentification
    ,
    CltuLastProcessed
    ,
    CltuLastOk
    ,
    CltuNotification
    ,
    CltuStatus
    ,
    DiagnosticCltuGetParameter
    ,
    DiagnosticCltuStart
    ,
    DiagnosticCltuThrowEvent
    ,
    DiagnosticCltuTransferData
    ,
    EventInvocationId
    ,
    NumberOfCltusProcessed
    ,
    NumberOfCltusRadiated
    ,
    NumberOfCltusReceived
    ,
    ProductionStatus
    ,
    UplinkStatus
FROM CCSDS-SLE-TRANSFER-SERVICE-CLTU-STRUCTURES
;
```

```
-- =====
-- The first part of the module definition contains the CLTU type
-- that contains all the possible PDUs the provider may send.
-- =====
```

RECOMMENDED STANDARD FOR SLE FCLTU SERVICE

```

CltuProviderToUserPdu ::= CHOICE
{
  cltuBindReturn          [101] SleBindReturn
,
  cltuUnbindReturn       [103] SleUnbindReturn
,
  cltuStartReturn        [1]   CltuStartReturn
,
  cltuStopReturn         [3]   SleAcknowledgement
,
  cltuScheduleStatusReportReturn [5]
                               SleScheduleStatusReportReturn
,
  cltuGetParameterReturn [7]   CltuGetParameterReturn
,
  cltuThrowEventReturn   [9]   CltuThrowEventReturn
,
  cltuTransferDataReturn [11]  CltuTransferDataReturn
,
  cltuAsyncNotifyInvocation [12] CltuAsyncNotifyInvocation
,
  cltuStatusReportInvocation [13] CltuStatusReportInvocation
,
  cltuPeerAbortInvocation [104] SlePeerAbort
}

```

```

-- =====
-- The second part of the module definition contains the types
-- used by the FCLTU-PDUs declared in the first part.
-- =====

```

```

CltuAsyncNotifyInvocation ::= SEQUENCE
{
  invokerCredentials      Credentials
,
  cltuNotification        CltuNotification
,
  cltuLastProcessed       CltuLastProcessed
,
  cltuLastOk              CltuLastOk
,
  productionStatus        ProductionStatus
,
  uplinkStatus            UplinkStatus
}

```

```

CltuGetParameterReturn ::= SEQUENCE
{
  performerCredentials      Credentials
,
  invokeId                  InvokeId
,
  result                    CHOICE
  {
    positiveResult          [0]   CltuGetParameter
  ,
    negativeResult          [1]   DiagnosticCltuGetParameter
  }
}

```

```

CltuStartReturn ::= SEQUENCE
{
  performerCredentials      Credentials
,
  invokeId                  InvokeId
,
  result                    CHOICE
  {
    positiveResult          [0]   SEQUENCE
    {
      startRadiationTime    Time
    ,
      stopRadiationTime     ConditionalTime
    }
  ,
    negativeResult          [1]   DiagnosticCltuStart
  }
}

```

RECOMMENDED STANDARD FOR SLE FCLTU SERVICE

```
CltuStatusReportInvocation ::= SEQUENCE
{
  invokerCredentials      Credentials
,  cltuLastProcessed      CltuLastProcessed
,  cltuLastOk             CltuLastOk
,  cltuProductionStatus   ProductionStatus
,  uplinkStatus           UplinkStatus
,  numberOfCltusReceived  NumberOfCltusReceived
,  numberOfCltusProcessed NumberOfCltusProcessed
,  numberOfCltusRadiated  NumberOfCltusRadiated
,  cltuBufferAvailable    BufferSize
}

CltuThrowEventReturn ::= SEQUENCE
{
  performerCredentials      Credentials
,  invokeId                 InvokeId
,  eventInvocationIdentification EventInvocationId
,  result                   CHOICE
  {
    positiveResult          [0]  NULL
  ,  negativeResult          [1]  DiagnosticCltuThrowEvent
  }
}

CltuTransferDataReturn ::= SEQUENCE
{
  performerCredentials      Credentials
,  invokeId                 InvokeId
,  cltuIdentification       CltuIdentification
,  cltuBufferAvailable      BufferSize
,  result                   CHOICE
  {
    positiveResult          [0]  NULL
  ,  negativeResult          [1]  DiagnosticCltuTransferData
  }
}

END
```

ANNEX B

PRODUCTION STATUS

(NORMATIVE)

B1 OVERVIEW

This annex describes the states and transitions of the FCLTU production status, and presents in tabular form the effect of the `production-status` parameter value on the processing of CLTUs and operations of the FCLTU service.

B2 PRODUCTION STATUS TRANSITIONS

B2.1 The possible transitions of the `production-status` parameter value of the FCLTU service shall be as shown in figure B-1 below.

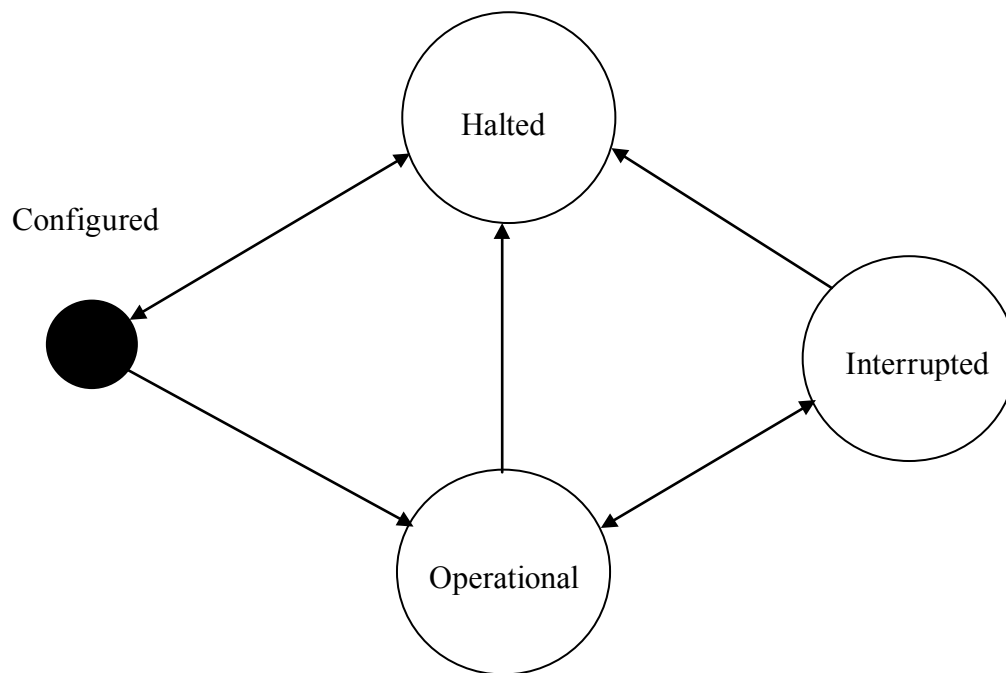

Figure B-1: FCLTU Production Status Transitions

B2.2 Changes of the `production-status` parameter value shall occur for the reasons outlined in table B-1. The notifications associated with `production-status` parameter value changes shall be as specified in table B-1.

Table B-1: Production Status Changes and Notifications

Start Status	End Status	Cause of Status Change	Notification
Configured	Operational	<p>Management action to make the production process operational; typically includes: completion of uplink sweep, and radiation of the acquisition sequence. Optionally, bit-lock and/or rf-available may be required before <code>production-status</code> can change to 'operational'. (See table 3-11, B2.3.2, and B2.4.2).</p> <p>If any error occurs that prevents the transition of <code>production-status</code> to 'operational', <code>production-status</code> will remain 'configured'. If <code>production-status</code> remains 'configured' for an extended period the user will have to check for the reasons by means outside the scope of this document.</p>	'production operational'
Operational	Interrupted	Occurrence of a production fault detected by the provider.	'production interrupted'; but see B2.3.3, B2.3.4, B2.3.5, B2.4.3, B2.4.5, and B2.4.6.
Interrupted	Operational	Maintenance action typically is required to correct a production fault. The FCLTU <code>production-status</code> returns to 'operational' when the provider detects that the fault is corrected.	'production operational'
[Any]	Halted	Direct management action is required, such as an operator directive causing the provider to halt production.	'production halted'
Halted	Configured	Direct management action is required, such as an operator directive restoring the desired configuration and setting <code>production-status</code> to 'configured'.	none

B2.3 PRODUCTION STATUS CHANGES IF PLOP-IN-EFFECT IS PLOP-1

B2.3.1 The initial `production-status` parameter value shall be 'configured'.

B2.3.2 When requested by the supported agency (either by schedule or via voice communication), the supporting agency shall start CMM-1 by turning on the uplink and performing the nominal uplink sweep in accordance with the mission specific parameters.

The `production-status` parameter value shall be changed from ‘configured’ to ‘operational’:

- a) at completion of the uplink sweep, if `rf-available-required` is set to ‘no’;
- b) at completion of the uplink sweep, if `rf-available-required` is set to ‘yes’ and the CLCW indicates ‘RF available’.

B2.3.3 While CMM-1 is active, `production-status` shall be changed from ‘operational’ to ‘interrupted’:

- a) if `rf-available-required` is set to ‘yes’ and the CLCW indicates ‘no RF lock’;
- b) at any other production interruption during CMM-1.

B2.3.4 While CMM-2 is active, `production-status` shall be changed from ‘operational’ to ‘interrupted’:

- a) at completion of the acquisition sequence, if `bit-lock-required` is set to ‘yes’ and the corresponding CLCW flags ‘no bit lock’;
- b) if `rf-available-required` is set to ‘yes’ and the CLCW indicates ‘no RF lock’;
- c) at any other production interruption during CMM-2.

B2.3.5 While CMM-3 or CMM-4 is active, `production-status` shall be changed from ‘operational’ to ‘interrupted’:

- a) if `bit-lock-required` is set to ‘yes’ and the CLCW flags ‘no bit lock’;
- b) if `rf-available-required` is set to ‘yes’ and the CLCW indicates ‘no RF lock’;
- c) at any other production interruption during CMM-3 or CMM-4.

B2.4 PRODUCTION STATUS CHANGES IF PLOP-IN-EFFECT IS PLOP-2

B2.4.1 The initial `production-status` parameter value shall be ‘configured’.

B2.4.2 When requested by the supported agency (either by schedule or via voice communication), the supporting agency shall start CMM-1 by turning on the uplink and performing the nominal uplink sweep in accordance with the mission specific parameters. The `production-status` parameter value shall be changed from ‘configured’ to ‘operational’:

RECOMMENDED STANDARD FOR SLE FCLTU SERVICE

- a) at completion of the uplink sweep, if `rf-available-required` is set to 'no' and `bit-lock-required` is set to 'no';
- b) at completion of the uplink sweep, if `rf-available-required` is set to 'yes' and the CLCW indicates 'RF available' and `bit-lock-required` is set to 'no'.

B2.4.3 While CMM-1 is active, `production-status` shall be changed from 'operational' to 'interrupted' if `rf-available-required` is set to 'yes' and the CLCW indicates 'no RF lock'.

B2.4.4 While CMM-2 or CMM-4 is active, `production-status` shall be changed to 'operational' if the CLCW flags 'bit lock'.

B2.4.5 While CMM-2 is active, `production-status` shall be changed to 'interrupted':

- a) at completion of the acquisition sequence, if `bit-lock-required` is set to 'yes' and the CLCW flags 'no bit lock';
- b) if `rf-available-required` is set to 'yes' and the CLCW flags 'no RF lock';
- c) at any other production interruption during CMM-2.

B2.4.6 While CMM-3 or CMM-4 is active, `production-status` shall be changed from 'operational' to 'interrupted':

- a) if `bit-lock-required` is set to 'yes' and the CLCW flags 'no bit lock';
- b) if `rf-available-required` is set to 'yes' and the CLCW indicates 'no RF lock';
- c) at any other production interruption during CMM-3 or CMM-4.

NOTES

- 1 This Recommended Standard does not require that a production interruption be notified immediately to the user (see 3.7.2.3). If a fault affecting production can be corrected before the provider attempts to process a CLTU, the 'production interrupted' notification need not be sent. It is an implementation choice whether always to send the 'production interrupted' notification immediately on occurrence of a production fault or to wait until a CLTU is ready to be radiated before sending the notification. The implementation choice is documented in the service configuration via the `notification-mode` parameter, which may have a value of 'immediate' or 'deferred', corresponding to immediate or deferred notification in the event of a production interruption.

- 2 The effect of `production-status` on the processing of FCLTU service invocations is specified in 3.1.10 through 3.12 and in table 4-1. The effects are summarized in table B-2 for convenient reference.

Table B-2: Effect of Production Status on Operations

Production Status	Operation	Effect	diagnostic
Halted	CLTU-BIND	Rejected	'out of service'
	CLTU-START	Rejected	'out of service'
	CLTU-TRANSFER-DATA	Rejected	'unable to process'
	Other operations	None specified	N/A
Configured	All operations	None specified	N/A
Operational	All operations	None specified	N/A
Interrupted	CLTU-START	Rejected	'unable to comply'
	CLTU-TRANSFER-DATA	Rejected; but see NOTE	'unable to process'
	Other operations	None specified	N/A

NOTE – When the value of the `notification-mode` parameter is 'deferred', CLTU-TRANSFER-DATA invocations are rejected only after the provider has notified the user that a production interruption has occurred. (See 3.7.2.3.)

ANNEX C

CONFORMANCE OPTIONS MATRIX

(NORMATIVE)

This annex provides the Conformance Matrix for implementations of FCLTU service systems. An FCLTU service system will be considered to conform to this Recommended Standard if the mandatory elements identified in tables C-1 and C-2 are implemented as described in this Recommended Standard.

Table C-1: Conformance Matrix for the FCLTU Service (Operations)

FCLTU Operations	Optional / Mandatory
CLTU-BIND CLTU-UNBIND	These operations are mandatory. All parameters are also mandatory with the exception of: invoker-credentials performer-credentials Support of the version-number negotiation as part of the CLTU-BIND operation is optional.
CLTU-START CLTU-STOP CLTU-TRANSFER-DATA CLTU-ASYNC-NOTIFY CLTU-SCHEDULE-STATUS-REPORT CLTU-STATUS-REPORT CLTU-GET-PARAMETER	These operations are mandatory. All parameters are also mandatory with the exception of: invoker-credentials performer-credential stop-production-time
CLTU-THROW-EVENT	This operation is optional.
CLTU-PEER-ABORT	This operation is mandatory. The diagnostic parameter is also mandatory.

Table C-2: Conformance Matrix for the FCLTU Service (Other Requirements)

Other Sections	Optional / Mandatory
protocol-abort-mode parameter (see table 3-1 and 4.1.5.4)	The parameter is optional. The default behavior of the provider in event of protocol abort shall be as described for the 'flush' value of the protocol-abort-mode parameter.
notification-mode parameter (see table 3-1 and 3.7.2.3)	This parameter is optional; its purpose is only to document the behavior of the provider.
Provider buffering requirements (see 3.1.10)	Mandatory minimum size is 4,194,304 octets. NOTE – This number is equivalent to 1024 CLTUs each of length of 4096 octets.
State transition table (see table 4-1)	Mandatory.
ASN.1 protocol specification (annex A)	All data types are mandatory. Implementations may vary as described in the annex.

ANNEX D

INDEX TO DEFINITIONS

(INFORMATIVE)

This annex provides an index to the terminology defined in the references.

Term	Reference
(data) type	reference [6]
(data) value	reference [6]
abstract binding	reference [1]
abstract object	reference [1]
abstract port	reference [1]
abstract service	reference [1]
abstract syntax	reference [7]
Abstract Syntax Notation One (ASN.1)	reference [6]
acquisition sequence	reference [2]
application entity	reference [7]
application layer	reference [7]
application process	reference [7]
association	subsection 1.6.1.6.1
Carrier Modulation Mode (CMM)	reference [2]
CLTU channel	reference [1]
Communications Link Control Word (CLCW)	reference [3]
Communications Link Transmission Unit (CLTU)	reference [2]
communications service	subsection 1.6.1.6.2
confirmed operation	subsection 1.6.1.6.3
flow control	reference [7]
Forward CLTU service	reference [1]
idle sequence	reference [2]
initiator	subsection 1.6.1.6.4
invocation	subsection 1.6.1.6.5
invoker	reference [1]

RECOMMENDED STANDARD FOR SLE FCLTU SERVICE

Term	Reference
Mission Data Operation System (MDOS)	reference [1]
Mission User Entity (MUE)	reference [1]
object identifier	reference [6]
offline delivery mode	reference [1]
online delivery mode	reference [1]
Open System Interconnection (OSI)	reference [7]
operation	reference [1]
parameter	subsection 1.6.1.6.6
performance	subsection 1.6.1.6.8
performer	reference [1]
physical channel	reference [1]
Physical Layer Operations Procedure (PLOP)	reference [2]
port identifier	subsection 1.6.1.6.9
real system	reference [7]
responder	subsection 1.6.1.6.10
return	subsection 1.6.1.6.11
Service Access Point (SAP)	reference [7]
service instance provision period	subsection 1.6.1.6.12
service provider (provider)	reference [1]
service user (user)	reference [1]
SLE Complex	reference [1]
SLE Complex Management	reference [1]
SLE data channel	reference [1]
SLE functional group (SLE-FG)	reference [1]
SLE protocol data unit (SLE-PDU)	reference [1]
SLE service data unit (SLE-SDU)	reference [1]
SLE service package	reference [1]
SLE transfer service instance	reference [1]
SLE transfer service production	reference [1]
SLE transfer service provision	reference [1]
SLE Utilization Management	reference [1]
space link	reference [1]

RECOMMENDED STANDARD FOR SLE FCLTU SERVICE

Term

space link data channel

space link data unit (SL-DU)

space link session

unconfirmed operation

Reference

reference [1]

reference [1]

reference [1]

subsection 1.6.1.6.13

ANNEX E

ACRONYMS

(INFORMATIVE)

This annex expands the acronyms used throughout this Recommended Standard.

AOS	Advanced Orbiting System (space link protocol)
ASN.1	Abstract Syntax Notation One
C	Conditional
CCSDS	Consultative Committee for Space Data Systems
CDS	CCSDS Day Segmented (time code)
CLCW	Communications Link Control Word
CLTU	Communications Link Transmission Unit
CLTU-	FCLTU service (operation prefix)
CMM	Carrier Modulation Mode
COP	Communications Operation Procedure
FCLTU	Forward CLTU (SLE transfer service)
fwd	forward
IEC	International Electrotechnical Commission
IP	Internet Protocol
ISO	International Organization for Standardization
M	Mandatory
MDOS	Mission Data Operation System
M-P	Management Provider Service Port
M-U	Management User Service Port
MUE	Mission User Entity

RECOMMENDED STANDARD FOR SLE FCLTU SERVICE

OCF	Operational Control Field
OSI	Open System Interconnection
PDU	Protocol Data Unit
PLOP	Physical Layer Operations Procedure
RF	Radio Frequency
SAP	Service Access Point
SDU	Service Data Unit
SL-DU	Space Link Data Unit
SLE	Space Link Extension
SLE-FG	SLE Functional Group
SLE-PDU	SLE Protocol Data Unit
SLE-SDU	SLE Service Data Unit
TC	Telecommand
TCP	Transmission Control Protocol
TM	Telemetry (space link protocol)
T-P	Transfer Provider Service Port
T-U	Transfer User Service Port
USLP	Unified Space Data Link Protocol
UTC	Universal Time Coordinated
WAN	Wide Area Network

ANNEX F

THROW EVENT DEFINITIONS

(INFORMATIVE)

This annex provides several examples of event-identification and event-qualifier for the CLTU-THROW-EVENT operation. These examples are non-binding on implementations of the SLE FCLTU service system; however, they may serve as models for implementations when the matching functionality is supplied. The examples assume that low-rate commanding is applicable, i.e. the telecommand data stream (NRZ-L)BPSK modulates a 16 kHz subcarrier which in turn phase modulates the carrier. Because of this assumed modulation scheme, the maximum bit rate is 4000 bits per second.

In the following table the event-qualifier Contents column defines the string passed in the event-qualifier parameter. Values such as 'on' and 'mi' are literal. Values such as
 represent an alphanumeric quantity. At least one white space must separate values in the event-qualifier string.

Table F-1: Throw Event Examples

event-identification		event-qualifier Contents [Range]	Event Description
Name	ID		
Set Mod	1	on off	Enable or disable command modulation of the carrier. See NOTE 1.
Change Rate	2	br [7.8125 – 4000.0]	Change bit rate to new bit rate defined by (requested new bit rate is the value of in bits/second). See NOTE 2.
Change Index	3	mi <MI> [1 – 1570]	Change modulation index to new modulation index defined by <MI> (requested new modulation index is the value of <MI> in milli-radians). See NOTE 2.
Change Rate/Index	4	br mi <MI>	Change both bit rate and modulation index as described above. See NOTE 2.

RECOMMENDED STANDARD FOR SLE FCLTU SERVICE

NOTES

- 1 The following condition is required for the Set Mod event with the event-qualifier parameter value set to 'on': production-status must be 'operational'. If this condition is not met, CLTU-ASYNC-NOTIFY is invoked with the notification-type 'event condition evaluated to false'.
- 2 The following conditions are required for the Change Rate, Change Index, and Change Rate/Index events: no CLTUs may currently be radiating, and the CLTU buffer must be empty. If these conditions are not met, CLTU-ASYNC-NOTIFY is invoked with the notification-type 'event condition evaluated to false'.

ANNEX G

INFORMATIVE REFERENCES

(INFORMATIVE)

- [G1] *Telecommand Part 1—Channel Service*. Issue 3-S. Recommendation for Space Data System Standards (Historical), CCSDS 201.0-B-3-S. Washington, D.C.: CCSDS, (June 2000) August 2005.
- [G2] *Telecommand Part 2—Data Routing Service*. Issue 3-S. Recommendation for Space Data System Standards (Historical), CCSDS 202.0-B-3-S. Washington, D.C.: CCSDS, (June 2001) August 2005.
- [G3] *Telecommand Part 2.1—Command Operation Procedures*. Issue 2-S. Recommendation for Space Data System Standards (Historical), CCSDS 202.1-B-2-S. Washington, D.C.: CCSDS, (June 2001) August 2005.
- [G4] *Telecommand Part 3—Data Management Service*. Issue 2-S. Recommendation for Space Data System Standards (Historical Recommendation), CCSDS 203.0-B-2-S. Washington, D.C.: CCSDS, (June 2001) August 2005.
- [G5] *Space Link Extension—Internet Protocol for Transfer Services*. Issue 2. Recommendation for Space Data System Standards (Blue Book), CCSDS 913.1-B-2. Washington, D.C.: CCSDS, September 2015.
- [G6] *Space Data Link Security Protocol*. Issue 2. Recommendation for Space Data System Standards (Blue Book), CCSDS 355.0-B-2. Washington, D.C.: CCSDS, July 2022.